



## Compliance Information

**Manufacturer:** Nidec Control Techniques Limited ("we", "our")

**Registered office:** The Gro, Newtown, Powys, SY16 3BE United Kingdom

**Registered in:** England and Wales, company registration number 01236886

**Manufacturer's EU Authorised Representative:** Nidec Netherlands B.V., Kubus 155, 3364 DG Sliedrecht, the Netherlands, registered at the Dutch Trade Register under number 33213151; Tel. +31 (0)184 420 555, info.nl@mail.nidec.com

### Original instructions

With reference to the UK Supply of Machinery (Safety) Regulations 2008 and the EU Machinery Directive 2006/42/EC, the English version of this Manual constitutes the original instructions. Manuals published in other languages are translations of the original instructions and the English language version of this Manual prevails over any other language version in the event of inconsistency.

### Documentation and user software tools

Manuals, datasheets and software that we make available to users of our products can be downloaded from: <http://www.drive-setup.com>

**MARSHAL** (Mobile App): This application is available for download from the Google Play Store and the Apple App Store.

### Warranty and liability

The contents of this Manual are presented for information purposes only, and while every effort has been made to ensure their accuracy, they are not to be construed as warranties or guarantees, express or implied, regarding the products or services described herein or their use or applicability. All sales are governed by our terms and conditions, which are available on request. We reserve the right to modify or improve the designs, specifications or performance of our products at any time without notice. For full details of the warranty terms applicable to the product, contact the supplier of the product.

In no event and under no circumstances shall we be liable for damages and failures due to misuse, abuse, improper installation, or abnormal conditions of temperature, dust, or corrosion, or failures due to operation outside the published ratings for the product, nor shall we be liable for consequential and incidental damages of any kind.

### Environmental management

We operate an Environmental Management System which complies with the requirements of ISO 14001:2015. Further information on our Environmental Statement can be found at:

<http://www.drive-setup.com/environment>.

### Restriction and control of hazardous substances

The products covered by this Manual comply with the following legislation and regulations on the restriction and control of hazardous substances:

UK Restriction of the Use of Certain Hazardous Substances in Electrical and Electronic Equipment Regulations 2012

UK REACH etc. (Amendment etc.) (EU Exit) Regulations 2020, European Union REACH Regulation EC 1907/2006

EU restriction of the Use of certain Hazardous Substances in Electrical and Electronic Equipment (RoHS) - Directive 2011/65/EU

EC Regulation 1907/2006 on the Registration, Evaluation, authorisation, and restriction of Chemicals (REACH)

Chinese Administrative Measures for Restriction of Hazardous Substances in Electrical and Electronic Products 2016/07/01

U.S. Environmental Protection Agency ("EPA") regulations under the Toxic Substances Control Act ("TSCA")

MEPC 68/21 / Add.1, Annex 17, Resolution MEPC.269(68) 2015 Guidelines for the development of the inventory of hazardous materials

The products covered by this Manual do not contain asbestos.

Further information on REACH and RoHS can be found at:

<http://www.drive-setup.com/environment>.

### Conflict minerals

With reference to the Conflict Minerals (Compliance) (Northern Ireland) (EU Exit) Regulations 2020, the U.S. Dodd-Frank Wall Street Reform and Consumer Protection Act and Regulation (EU) 2017/821 of the European Parliament and of the European Council:

We have implemented due diligence measures for responsible sourcing, we conduct conflict minerals surveys of relevant suppliers, we continually review due diligence information received from suppliers against company expectations and our review process includes corrective action management. We are not required to file an annual conflict minerals disclosure. Nidec Control Techniques Limited is not an issuer as defined by the U.S. SEC.

### Disposal and recycling (WEEE)



The products covered by this Manual fall within the scope of the UK Waste Electrical and Electronic Equipment Regulations 2013, EU Directive 2012/19/EU amended by EU Directive 2018/849 (EU) on Waste Electrical and Electronic Equipment (WEEE).

When electronic products reach the end of their useful life, they must not be disposed of along with domestic waste but should be recycled by a specialist recycler of electronic equipment. Our products are designed to be easily dismantled into their major component parts for efficient recycling. Most materials used in our products are suitable for recycling.

Our product packaging is of good quality and can be re-used. Smaller products are packaged in strong cardboard cartons which have a high recycled fibre content. Cartons can be re-used and recycled. Polythene, used in protective film and bags for the ground screws, can be recycled. When preparing to recycle or dispose of any product or packaging, please observe local legislation and best practice.

### Copyright and trade marks

Copyright © 2 August 2021 Nidec Control Techniques Limited. All rights reserved.

No part of this Manual may be reproduced or transmitted in any form or by any means including by photocopying, recording or by an information storage or retrieval system, without our permission in writing.

The Nidec logo is a trade mark of Nidec Corporation. The Control Techniques logo is a trade mark owned by Nidec Control Techniques Limited. All other marks are property of their respective owners.

---

# Contents

---

<b>1</b>	<b>Information .....</b>	<b>9</b>
1.1	Safety of personnel .....	9
1.2	Warnings, cautions and notes .....	9
1.3	Definition of terms .....	9
1.4	Terms and abbreviations .....	10
1.5	Intended use .....	13
1.6	General safety instructions .....	14
1.7	Electrical safety - general warning .....	14
1.8	System design and safety of personnel .....	14
1.9	Environmental limits .....	15
1.10	Compliance with regulations .....	15
1.11	Design of safe machinery, risk assessment & safety standards .....	15
1.12	Functional safety of electrical power drive systems .....	16
1.12.1	Mechanical brake control .....	16
1.13	Responsibilities .....	16
1.14	Avoiding malfunction during loss of zero volts .....	16
1.15	Operation and service .....	16
1.16	Transportation / storage .....	16
<b>2</b>	<b>Introduction .....</b>	<b>17</b>
2.1	Overview .....	17
2.2	Configuration .....	18
2.2.1	Addressing scheme .....	18
2.2.2	Session management .....	18
2.2.3	Downloading the configuration .....	19
2.2.4	Testing the configuration .....	19
2.3	Identification .....	19
2.4	Items supplied .....	20
<b>3</b>	<b>Technical Safety Features .....</b>	<b>21</b>
3.1	Digital IO .....	22
3.1.1	Diagnostic coverage for inputs .....	23
3.1.2	Diagnostic coverage for outputs .....	24
3.2	Encoders .....	25
3.2.1	Diagnostic coverage for encoders .....	27
3.2.2	Encoder Mathematics .....	29
3.2.3	Drive encoder interface (EnDat 2.2 and Safe EnDat 2.2) .....	32
3.2.4	Local encoder interface (EnDat 2.2, Safe EnDat 2.2 and SSI) .....	32
3.2.5	Cable attenuation (EnDat 2.2, Safe EnDat 2.2 and SSI) .....	33
3.2.6	AB and Sin/Cos encoder interface .....	33
3.2.7	Process encoder values .....	34
3.3	Embedded microcontroller and support devices .....	35
3.3.1	Diagnostic coverage summary .....	36
3.4	Response times .....	36
3.4.1	Networks .....	36

<b>4</b>	<b>Installation .....</b>	<b>38</b>
4.1	General installation notes .....	38
4.2	Mounting on the drive .....	39
4.2.1	MiS210 on M600, M700 (HS70), M701 (HS71) and M702 (HS72)	39
4.2.2	Physical connection	40
4.2.3	MiS250 on M750, M751 and M753	40
4.2.4	Physical connection of MiS250	41
4.3	Connection of Digital IO .....	42
4.3.1	Wiring for input pair with no checking	43
4.3.2	Wiring for input pair with checking	43
4.3.3	Wiring of output	44
4.4	Connection of encoder(s) and encoder power supplies .....	45
4.4.1	Power supplies	45
4.4.2	Wiring	46
4.5	Cables .....	48
<b>5</b>	<b>Connect Configuration Tool Introduction .....</b>	<b>50</b>
5.1	Connect screen images .....	50
5.1.1	Network	50
5.1.2	Encoders	52
5.1.3	System	53
5.1.4	Functions	54
5.1.5	Inputs	54
5.1.6	Outputs	57
5.1.7	Scope	59
5.2	Configuration - Introduction .....	60
5.2.1	Connecting and configuring individual function blocks	61
5.2.2	Categories of I/O	61
5.2.3	Motion safety functions	62
5.2.4	Diagnostic codes	63
5.2.5	Module menu	63
5.2.6	Safety configuration system data types	64
<b>6</b>	<b>Start Up .....</b>	<b>65</b>
<b>7</b>	<b>Validation .....</b>	<b>67</b>
7.1	Overview .....	67
7.2	Format .....	67
7.3	Declaration .....	68

<b>8</b>	<b>Motion Safety Function Details .....</b>	<b>69</b>
8.1	Encoder setup .....	69
8.2	Module configuration & control .....	72
8.3	Safety network configuration .....	75
8.3.1	CIPSafety configuration .....	75
8.3.2	FSoE configuration .....	79
8.3.3	Network parameters .....	83
8.4	Scope Access .....	84
8.5	Safe Equivalent, SEQV .....	84
8.6	Safe Not Equivalent, SNEQV .....	90
8.7	Safe Emergency Stop, SES .....	96
8.8	Safe Stop, SS .....	104
8.8.1	Safe Stop 1, SS1 .....	111
8.8.2	Safe Stop 2, SS2 .....	112
8.9	Safely Limited Speed, SLS .....	113
8.10	Safe Two-Handed Control Type 3, STHC3 .....	127
8.11	Safe Operating Stop, SOS .....	134
8.12	Safely Limited Acceleration, SLA .....	138
8.13	Safe Speed Monitoring, SSM .....	145
8.14	Safe Datum, SDM .....	146
8.15	Safely Limited Position, SLP .....	154
8.16	Safe Direction, SDI .....	161
8.17	Safe Brake Control, SBC .....	163
8.18	Safe OR, SOR .....	174
8.19	Safe Not OR, SNOR .....	175
8.20	Safe Exclusive OR, SXOR .....	176
8.21	Safe Exclusive Not OR, SXNOR .....	177
8.22	Safe AND, SAND .....	178
8.23	Safe Not AND, SNAND .....	179
8.24	Safe 8 AND, S8AND .....	180
8.25	Safe Boolean Hardware Inputs, SHIS .....	181
8.26	Safe Torque Off, STO .....	188
8.27	Safe Boolean Hardware Outputs, SHOS .....	192
8.28	Safe Boolean Network Inputs, SNIS .....	197
8.29	Safe Boolean Network Outputs, SNOS .....	199
8.30	Safe Integer Network Inputs, SINIS .....	203
8.31	Safe Integer Network Outputs, SINOS .....	205
8.32	Safe FALSE, SFIS .....	208
8.33	Safe Constant Integer, SCIS .....	209
8.34	Non-Safe Boolean Input, BIS .....	210
8.35	Non-Safe Boolean Output, BOS .....	211
<b>9</b>	<b>Diagnostics and Maintenance .....</b>	<b>213</b>
9.1	Diagnostic code categories .....	213
9.1.1	Operational diagnostics category .....	213
9.1.2	Fault diagnostics category .....	214
9.2	MiS2x0 alarm list .....	215
9.3	MiS2x0 fault list .....	217
9.4	Safety DLL fault list .....	221
9.5	Maintenance .....	223
9.5.1	Module replacement .....	223
9.5.2	Maintenance intervals .....	223
9.5.3	Diagnostic parameters (Module menu) .....	223
9.5.4	Factory Reset .....	226
<b>10</b>	<b>Key Safety Data .....</b>	<b>227</b>
<b>11</b>	<b>Version Control (Amendments) .....</b>	<b>228</b>

---

# EU Declaration of Conformity

---

## 1. Product Model

The MiS210 and MiS250 Option modules are used as a Safety Components of a machine.

The MiS210 and MiS250 are intended to be used with the Unidrive-M range of variable speed drives to implement the following safety functions as defined in EN 61800-5-2:

STO, SS1, SS2, SLS, SOS, SDI, SSM, SES, SOR, SNOR, SXOR, SNXOR, SAND, SNAND, SHIS, SHOS, SNIS, SNOS, SINIS, SINOS, STIS, SFIS, SCIS, BIS, BOS, SLP, SDM, SBC, SLA, STHC3, S8AND.

The Option Modules are used with the Parameterisation Tool - Connect, incorporating the Safety DLL.

The Option modules are programmable devices. The programming tool (Parameterisation Tool) is within the scope of the type examination certificate.

## 2. Name and Address of the Manufacturer

Manufacturer:	Authorised representative:
Nidec Control Techniques Ltd The Gro Newtown Powys SY16 3BE UK  Registered in England and Wales. Company Reg. No. 01236886	Nidec Netherlands B.V. Kubus 155 3364 DG Sliedrecht Netherlands

## 3. Responsibility

This declaration is issued under the sole responsibility of the manufacturer.

## 4. Object of the Declaration

MiS210, MiS250 Option Modules

## 5. Declaration

Only the Safe Torque Off function may be used for a safety function of a machine. None of the other functions of the drive may be used to carry out a safety function.

The object of the declaration is in conformity with the relevant European Union harmonisation legislation.

Type examination has been carried out by the following notified body:

TUV Rheinland Industrie Service GmbH, Am Grauen Stein, D-51105 Köln, Germany

Notified body identification number: 0035

EC type-examination certificate number: 01/205/5720.00/19 dated 2019-06-17

## 6. References to the relevant harmonised standards used

The variable speed drive products listed above have been designed and manufactured in accordance with the following European harmonised standards:

BS EN 61800-5-2:2016	Adjustable speed electrical power drive systems - Part 5-2: Safety requirements - Functional
BS EN 61800-5-1:2016 (in extracts)	Adjustable speed electrical power drive systems - Part 5-1: Safety requirements - Electrical, thermal and energy
BS EN 61800-3: 2004 + A1: 2012	Adjustable speed electrical power drive systems - Part 3: EMC requirements and specific test methods
BS EN ISO 13849-1:2015	Safety of Machinery, Safety-related parts of control systems, General principles for design
BS EN 62061:2005 + AC:2010 + A1:2013 + A2:2015	Safety of machinery, Functional safety of safety related electrical, electronic and programmable electronic control systems
BS EN 61508 Parts 1 - 7:2010	Functional safety of electrical/ electronic/programmable electronic safety-related systems

## 7. Signed for and on behalf of:

Person authorised to complete the technical file:      Authorised representative (see details above)

DoC authorised by:



**Jon Holman-White**  
**Director of Research and Development**  
**24th November 2021**  
**Newtown, Powys, UK**

Date:

Place:

## IMPORTANT NOTICE

**This electronic module is intended to be used with motors, variable speed drives, controllers, electrical protection components and other equipment to form a complete power drive system (PDS).**

**It is the responsibility of the installer to ensure that the design of the system and machine, including its safety-related control system, is carried out in accordance with the requirements of the Machinery Directive and any other relevant legislation.**

**The use of a safety component does not ensure the safety of the machine.**

**Compliance with safety and EMC regulations depends upon installing and configuring drives correctly, including using the specified input filters.**

**The drive must be installed only by professional installers who are familiar with requirements for safety and EMC.**

**The assembler is responsible for ensuring that the final product or system complies with all relevant laws in the country where it is to be used. For more information regarding Safe Torque Off, refer to the Product Documentation.**

# 1 Information

## 1.1 Safety of personnel

Definition of individual target groups:

Personnel involved in projects relating to safe drive systems

Engineers and Technical Staff

Assembly, electrical installation, maintenance and equipment replacement

Plant Electricians and Service Technicians

Start-up, operation and configuration

Engineers and Technical Staff

The MiS210 and MiS250 Safety Modules are for use in Safety Related Control Systems, the design of such systems MUST only be done by personnel who are suitably trained and experienced.

## 1.2 Warnings, cautions and notes



A **Warning** contains information which is essential for avoiding a safety hazard.



A **Caution** contains information which is necessary for avoiding a risk of damage to the equipment and motor.

### NOTE

A **Note** contains information which helps to ensure correct operation of the product.

In Section 8 Motion Safety Function, there are sections written in red text, these indicate additional warning information to do with a specific functionality.

## 1.3 Definition of terms

The term MiS2x0 Safety Module is used to describe all derivatives of the Safety Module product line. If reference is made in this description to a defined derivative, the complete designation is always employed.

The term 'safe' as used in this manual refers in each instance to the assignment of a safe function for applications extending up to PL e, as defined in ISO 13849-1:2008 and/or SIL 3 in accordance with IEC 61508.

The systems software 'Connect' is used for configuration of both the MiS210 and the MiS250 Safety Modules.

**Table 1-1 Other applicable documents**

Description	Reference
Configuration of the MiS2x0 Safety Module for standalone applications with the 'Connect' program.	Section 4 of this document and 'Connect' context help text.
Validation report for implemented PLC program and parameters.	Safety inspection with approval record.
Approval.	TÜV certificate for product modules MiS2x0 Safety Module.

**NOTE**

Read the relevant manuals carefully before installing and commissioning the MiS2x0 Safety Module. Compliance with all documentation is essential for fault free operation, and to safeguard cover in the event of a warranty claim.

Throughout this manual, technical standards are referred to by their international designations (e.g. IEC 61800-5-2 and ISO 13849-1). To comply with European Union law, the EN versions should be applied (e.g. EN 61800-5-2 and EN ISO 13849-1), which are identical to the corresponding international standards in their technical content.

## 1.4 Terms and abbreviations

**Table 1-2 Terms and abbreviations**

Abbreviation	Description
1oo2	1 Out Of 2
AC	Alternating Current
BIT Failure	Built in Test Failure - an internal test has failed
BIS	Non-safe Boolean Input
Black Channel	A black channel is a protocol that operates in the application layer of a network and so is independent of specific network characteristics, in safety applications mechanisms such as CRCs and dual packet transmission ensures the integrity of the data.
BOS	Non-safe Boolean Output
CCF	Common Cause Failures
CFUNID	ConFiguRation Unique IDentification
CLK	Clock
DC	Direct Current
DC <sub>avg</sub>	Diagnostic Cover level on demand
ECHA	European Chemical Agency
EEPROM	Electrically Erasable Programmable Read-Only Memory
ELV	Extra Low Voltage
EMC	Electromagnetic Compatibility
EMS	Environmental Management System
EN	European standard
EU	European Union
FE	Falling Edge
FIT	Failure in Time
FSoE	Fail Safe over EtherCAT
HSW	Health and Safety at Work
IO	Input Output
IP20	Protection class for enclosures

Abbreviation	Description	
ISO	International Organization for Standardization	Information
MSF	Motion Safety Functions	
MTBF	Mean Time Between Failures	Introduction
MTTF <sub>d</sub>	Mean Time To Failure in the dangerous direction	
OCPUNID	Output Connection Point owning Unique IDentification	Technical Safety Features
OSSD	Output Signal Switch Device	
OUNID	Originator Unique IDentification	Installation
PC	Personal Computer	
PDS(SR)	Power Drive System suitable for use in Safety-Related applications	Connect Configuration Tool Introduction
PELV	Protected Extra Low Voltage	
PFH	Probability of Failure per Hour	Start Up
PES	Programmable Electronic System	
PL	Performance Level	Validation
PLC	Programmable Logic Control	
PSU	Power Supply Unit	Motion Safety Function Details
REACH	Registration, Evaluation, Authorization and restriction of Chemicals	
RPI	Requested Packet Interval	Diagnostics and Maintenance
S8AND	Safe 8 AND	
SAND	Safe AND	Key Safety Data
SBC	Safe Brake Control	
SCID	Safety Configuration IDentification	Version Control (Amendments)
SCIS	Safe Constant Integer	
SDI	Safe Direction	
SDM	Safe Datum	
SELV	Safety Extra Low Voltage	
SEQV	Safe Equivalent	
SES	Safe Emergency Stop	
SFIS	Safe FALSE	
SHIS	Safe Hardware Inputs	
SHOS	Safe Hardware Outputs	
SIL	Safety Integrity Level	
SINIS	Safe Integer Network Inputs	
SINOS	Safe Integer Network Outputs	
SLA	Safely Limited Acceleration	
SLP	Safely Limited Position	
SLS	Safely Limited Speed	
SNAND	Safe Not AND	
SNEQV	Safe Not Equivalent	
SNIS	Safe Network Inputs	
SNN	Safety Network Number	
SNOS	Safe Network Outputs	
SNOR	Safe Not OR	
SOR	Safe OR	
SOS	Safe Operating Stop	

Abbreviation	Description
SRP/CS	Safety Related Parts of a Control System
SS	Safe Stop (1 and 2)
SSI	Synchronous Serial Interface
SSM	Safe Speed Monitoring
STHC3	Safe Two-Handed Control Type 3
STIS	Safe TRUE
STO	Safe Torque Off
SXOR	Safe Exclusive OR
TUNID	Target Unique IDentification
TÜV	German Technical Inspections Organization

## 1.5 Intended use

The MiS2x0 Safety Module is a configurable safety controller used as a component in a safety system. This module is designed for the following uses:

- In EMERGENCY STOP equipment.
- As a safety components as defined in EC Machinery Directive 2006/42/EC.
- As a PES for risk reduction as defined in IEC 61508.
- In safety power circuits in accordance with IEC 60204-1.
- As a PES for functional safety as defined in IEC 62061.
- As an SRP/CS as defined in ISO 13849.
- As a device for producing the safety functions defined in IEC 61800-5-2.



The MiS2x0 Safety Module is a safety component as defined in Annex IV of the EC Machinery Directive 2006/42/EC. It was developed, designed and produced in strict accordance with the above directive, and with the EC EMC Directive 2004/108/EC.

Information
Introduction
Technical Safety Features
Installation
Connect Configuration Tool Introduction
Start Up
Validation
Motion Safety Function Details
Diagnostics and Maintenance
Key Safety Data
Version Control (Amendments)

## 1.6 General safety instructions



**WARNING**

- To avoid personal injury and damage to equipment, all work on this device must be carried out by personnel who have been trained in the technical aspects of electrical engineering.
- Each appropriately skilled person must be familiar with the operating instructions.
- Each appropriately skilled person must, as a minimum requirement, have an in-depth knowledge of the National Health and Safety at Work (HSW, i.e. accident prevention) specifications and legislation.
- Use of these devices is restricted to their intended use, in accordance with the previous itemized list. Due compliance with the figures and data listed in Table 10-1 is mandatory
- The contents of this installation manual provide the detailed information on the MiS2x0 functions and the installation procedure. Some details can be found in the 'Connect' context help, but this manual is the master for the device. Detailed knowledge and understanding of these aspects is vitally necessary prior to first time installation and/or modification of equipment functions or device parameters.
- Commissioning / Start-Up is only permitted on condition that the EMC directive is followed. Based on EMC test specifications IEC 55011:2007 + A2:2007 and IEC 61000-6-2:2005.
- For storage and transport, due compliance is required with the conditions defined in IEC 60068-2-6 in relation to the figures given in section 10.
- Compliance with the wiring and connection instructions in the 'Installation' chapter is mandatory.
- The applicable safety specifications must be observed in respect of this application.
- The configured monitoring functions and their parameters and links must be verified through the use of a validation report.
- Implementation of this module must be agreed and matched to the requirements of the relevant commissioning body.
- Never install or commission damaged products. Please report all instances of damage immediately to Nidec Control Techniques Ltd.
- Never open the housing and/or modify in any way.
- The inputs and outputs for standard functions, and/or the digital and analogue data transmitted by communication modules must never be used for safety-related applications.

## 1.7 Electrical safety - general warning

The voltages used in the drive can cause severe electrical shock and/or could be lethal. Extreme care is necessary at all times when working with or adjacent to the drive. Specific warnings are given at all relevant places in this manual.

## 1.8 System design and safety of personnel

Only functions which are explicitly described as safety functions may be used to ensure the safety of personnel, i.e. no other functions of the drive or its option modules must be used for safety-related functions.

The only safety function provided in the Control Techniques Drives is Safe Torque Off and this is utilized by the MiS2x0 Safety Module.

The Safe Torque Off function has been approved by TÜV Rheinland as meeting the requirements of the following standards, for the prevention of unexpected starting of the drive:

- IEC 61800-5-2:2007 SIL 3
- ISO 13849-1:2008 PL e

The Safe Torque Off function may be used in a safety-related application. The system designer is responsible for ensuring that the complete system is safe and designed correctly according to the relevant safety standards.

The design of safety-related systems requires specialist knowledge. To ensure that a complete control system is safe, it is necessary for the whole system to be designed according to recognized safety principles. The use of individual sub systems such as drives and option modules with safety functions, which are intended for safety-related applications, does not in itself ensure that the complete system is safe. It is the responsibility of the designer of the end product or application to ensure that it is safe and in compliance with the relevant regulations. Any application examples given in this guide are for illustration only and do not purport to represent complete solutions.

## 1.9 Environmental limits

Instructions in this Safety Manual regarding transport, storage, installation and use of the MiS2x0 Safety Module must be complied with, including the specified environmental limits. MiS2x0 Safety Module must not be subjected to excessive physical force.

## 1.10 Compliance with regulations

The installer is responsible for complying with all relevant regulations, such as national wiring regulations, accident prevention regulations and electromagnetic compatibility (EMC) regulations. Particular attention must be given to the areas of conductors, cable types in particular screening arrangements, the selection of fuses or other protection, and protective earth (ground) connections.

This manual contains instructions for achieving compliance with specific EMC standards.

Within the EU, all machinery in which this product is incorporated must comply with the following directives:

- 2006/42/EC: Machinery Directive.
- 2014/30/EU: Electromagnetic Compatibility.
- 2014/35/EU: Low Voltage Directive.
- 2011/65/EU: Restriction of Hazardous Substances Directive.

## 1.11 Design of safe machinery, risk assessment & safety standards

The safety features of a machine should be designed at the same time as its intended functions. An initial risk assessment should be carried out, which should be in accordance with the ISO 14121 standards (previously 1050). The risk assessment identifies whether safety-related control functions are needed in addition to the inherent safety features of the machine.

The standards currently available for the safety of machinery control systems are ISO 13849-1 and IEC 62061. ISO 13849-1 measures the degree of safety integrity by a "Performance level" with values from a (lowest) to e, while IEC 62061 uses the principles of IEC 61508 to give a SIL (Safety Integrity Level) from 1 (lowest) to 3. Both of these standards allow for the use of complex hardware and software in safety-related control systems.

## 1.12 Functional safety of electrical power drive systems

Standard IEC 61800-5-2 defines specific MSFs. Some types of MSFs can be carried out by the MiS2x0 Safety Module in conjunction with the drive. The activation of these functions is carried out through safety features on the machine such as door switches and light curtains, which can be connected directly to the MiS2x0 Safety Module. If more IO is required the connecting logic can be carried out in a separate safety controller (PLC), which can then be connected to the safe interface of the MiS2x0 Safety Module (either a physical input or a network input).

### 1.12.1 Mechanical brake control

The drive brake control functions are provided to allow well-coordinated operation of an external brake with the drive. While both drive hardware and software are designed to high standards of quality and robustness, they are not intended for use as safety functions, i.e. where a fault or failure would result in a risk of injury. In any application where the incorrect operation of the brake release mechanism could result in injury, independent protection devices of proven integrity must also be incorporated.

## 1.13 Responsibilities

It is the responsibility of the machine/equipment designer to ensure the safety of the machine/equipment, including the correct configuration and integration of the MiS2x0 Safety Module which is required to achieve the necessary safe operation. It is also the responsibility of the machine/equipment designer to ensure that the MiS2x0 Safety Module meets the requirements of the application, i.e. that the function specified is the correct one for the application and that the integrity data is adequate. Control Techniques are not responsible for:

- The correct configuration of the MiS2x0 Safety Module into a complete safety-related control system.
- The correct application of the MiS2x0 Safety Module or a safety-related control system in a machine.

## 1.14 Avoiding malfunction during loss of zero volts

To avoid unintended voltage errors at a safe output, the output circuit must always be returned to a 0 V terminal on the MiS2x0 Safety Module or the drive it is mounted upon.

## 1.15 Operation and service

Before installing or removing a module, or disconnecting signal lines, first isolate the module electrically, i.e. the drive should be powered down.

While installing or removing a module, take appropriate precautions to prevent electrostatic discharge on the externally routed terminals and plug connections.

## 1.16 Transportation / storage

Instructions regarding transportation, storage and proper handling must be followed. Climate specifications must be observed in accordance with section 10.

## 2 Introduction

### 2.1 Overview

The MiS2x0 Safety Module provides motion safety functionality for Control Techniques drives in accordance with the requirements of IEC 61800-5-2. PLCopen Safety part 1 has been used as a model for the Motion Safety Functions (MSFs) interfaces and behavior.

The function of the MiS2x0 Safety Module is to monitor the signals provided at its inputs and to activate its outputs in accordance with the MSF algorithms. Inputs may be directly connected to the MiS2x0 Safety Module or provided via a safe network. Similarly, outputs may be directly connected or networked.

The MSF algorithms may be selected and configured by the user in accordance with the requirements of their application and up to PLe in accordance with ISO 13849-1 and/or SIL 3 in accordance with IEC 61508 and IEC 62061. The Connect PC application is provided to the user for this purpose and allows the configuration to be created and then transferred using a safe mechanism into the MiS2x0 Safety Module.

The MiS210 Safety Module can be connected to Unidrive-M600, M700, M701 and M702 as well as the high-speed variants HS70, HS71 and HS72. The MiS250 Safety Module can only be connected to Digitax M750, M751 and M753.

**Table 2-1 Device connections**

Connections	MiS210	MiS250
Safe Input Pairs	4	4
Safe Outputs	2	2
Pulse Outputs	2	2
Local Encoders	2	2
Encoder Power Supply Monitoring	1	1
Local Encoder Power Supply	1	1
Drive Encoders	2	2
Integrated STO	1	None

**NOTE**

The MiS210 Safety Module can only be installed in option module slot 3 as this provides the direct connection to the drive STO via the Blade Connector.

The MiS250 Safety Module can only be installed in option slot 2 on Digitax.

**Figure 2-1 MiS210 Safety module connectors**

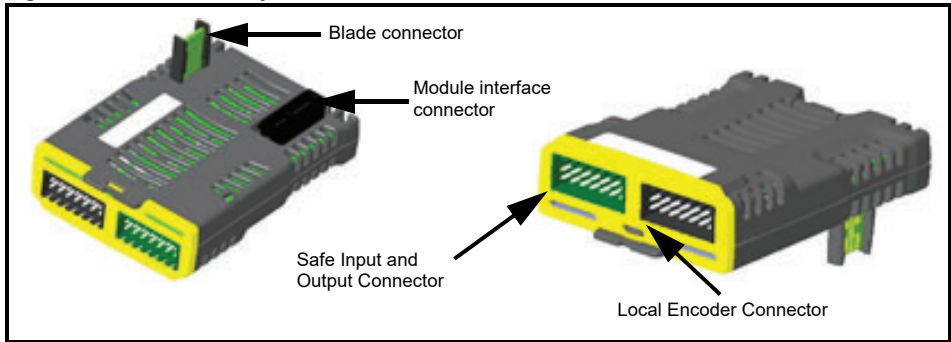

The MiS250 Safety Module looks identical to the MiS210 Safety Module except it does not have the Blade Connector.

## 2.2 Configuration

Connect is Control Techniques' graphical PC application for configuring and monitoring Control Techniques' drives and option modules, this is often known as a parameterization tool. The MiS2x0 Safety Module uses this application to provide consistency for Connect users. Connect allows a user to develop a motion safety configuration and transmit, using a black channel, it to the MiS2x0 Safety Module and then read it back for validation. A Validation Report, which is referred to as a "Sign-Off" report in Connect, is then produced that documents the configuration, see section 7.

The configuration is saved and protected against power supply failure within the MiS2x0 Safety Module, it can also be saved on the PC using Connect.

Refer to section 5 *Connect Configuration Tool Introduction*, for details of how to configure the MiS2x0 Safety Module.

Once a MiS2x0 Safety Module has been configured to work on a specific drive, if it is then moved to a different drive, the system must be re validated. The replacement of safety devices requires that the replacement device be configured properly, and operation of the replacement device shall be user verified.

### 2.2.1 Addressing scheme

The configuration of each MiS2x0 Safety Module within a system is performed via one of the various communications interfaces available, see section 2.2.3. The specific interface is hosted by the drive and has a network address to allow the drive to be uniquely identified. The configuration is transferred to and from the MiS2x0 via a black channel ensuring that the configuration owner and the channel end points are tied together.

On the first connection to the MiS2x0 Safety Module a robust identification process is enforced which ensures that MiS2x0 Safety Module and the configuration owner are uniquely identified, independently of network addresses.

### 2.2.2 Session management

The MiS2x0 Safety Module will only allow a single user, identified by a User ID and Password, to open a single session on the MiS2x0 Safety Module. Should the user then attempt a second login from a different platform using the same login credentials it will be ignored.

If a session is left open but no activity takes place for 30 minutes the session will time out and again

a fresh login is required.

There is a facility provided for the User ID and password to be changed, this can be done a maximum of 7 times after the MiS2x0 Safety Module has been identified with a User ID and password. After this the unit will need to be factory reset. (See section 9.5.4)

### 2.2.3 Downloading the configuration

The MiS2x0 Safety Module does not contain a communications interface thus configuration is done either via the drive's factory fitted RS-485 connection or via the drive's factory fitted communication port.

Where network safety critical communications are required, MiS2x0 Safety Module will only use the following recognized safety protocols, CIP Safety via the drive's factory fitted Ethernet port or FSoE via User Fit SI-EtherCAT on M600/70x drives or the factory fitted EtherCAT on M753.

### 2.2.4 Testing the configuration

Once a configuration is downloaded to the MiS2x0 it is the user's responsibility to test the configuration before producing the Validation Report for printing and signing. (See section 7) User testing is the means by which all downloads are validated, and signatures should only be considered verified after user testing has taken place.

## 2.3 Identification

The MiS2x0 Safety Module can be identified by the yellow colored front panel bezel. It also contains a label detailing the Name and Serial Number of the module.

Figure 2-2 Example MiS210 product label

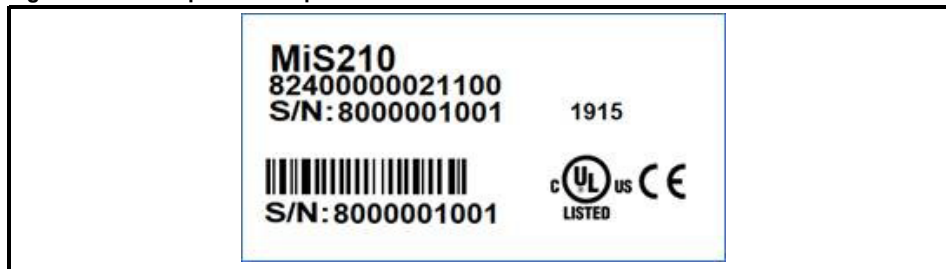

Figure 2-3 Example MiS210 carton label

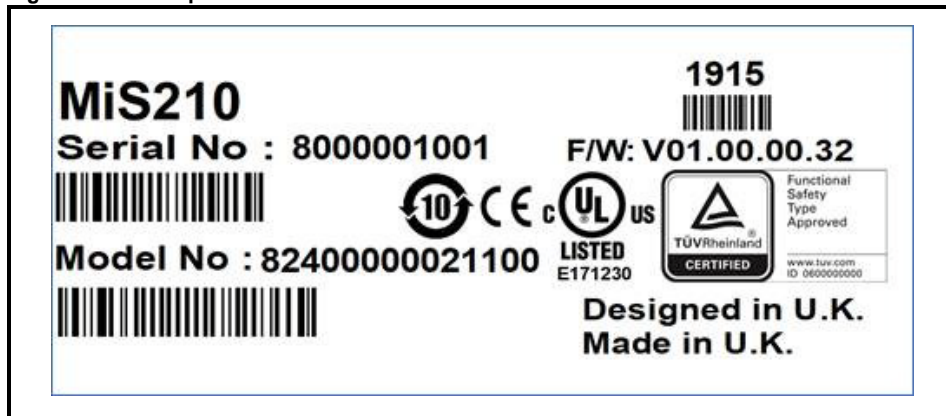

Figure 2-4 Example of MiS250 product label

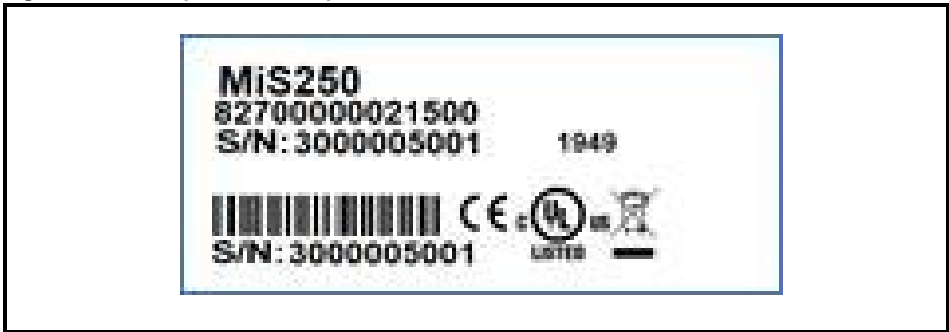
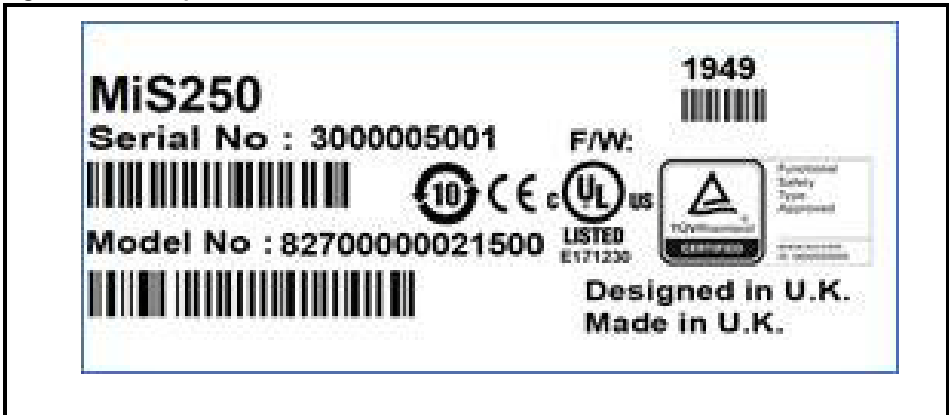

Figure 2-5 Example of MiS250 carton label



## 2.4 Items supplied

The Items supplied, when a MiS2x0 Safety Module is purchased are:

- MiS2x0 Safety Module.
- Front Panel Green IO Connector (CT Part Number 3432-0064).
- Front Panel Black Encoder Connector (CT Part Number 3432-0063).
- MiS2x0 Installation Sheet (0478-0515).
- STO Cable (CT Part Number 5321-0021) only applicable for MiS250

Connect is downloadable from the Nidec Control Techniques Ltd. website and the following version is needed.

- Connect (Safety Version) – Version Number 2.17.0.32.

### 3 Technical Safety Features

The overall architecture is configured as follows: [Sensor] [PES] [Actuator]

**Figure 3-1 Overall Architecture**

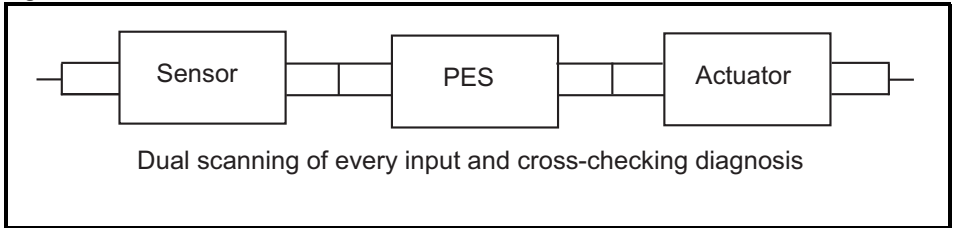

For the MiS210 Safety Module this is shown below in the top level architecture, showing the inputs and the outputs.

**Figure 3-2 Top level architecture of the MiS210 safety module**

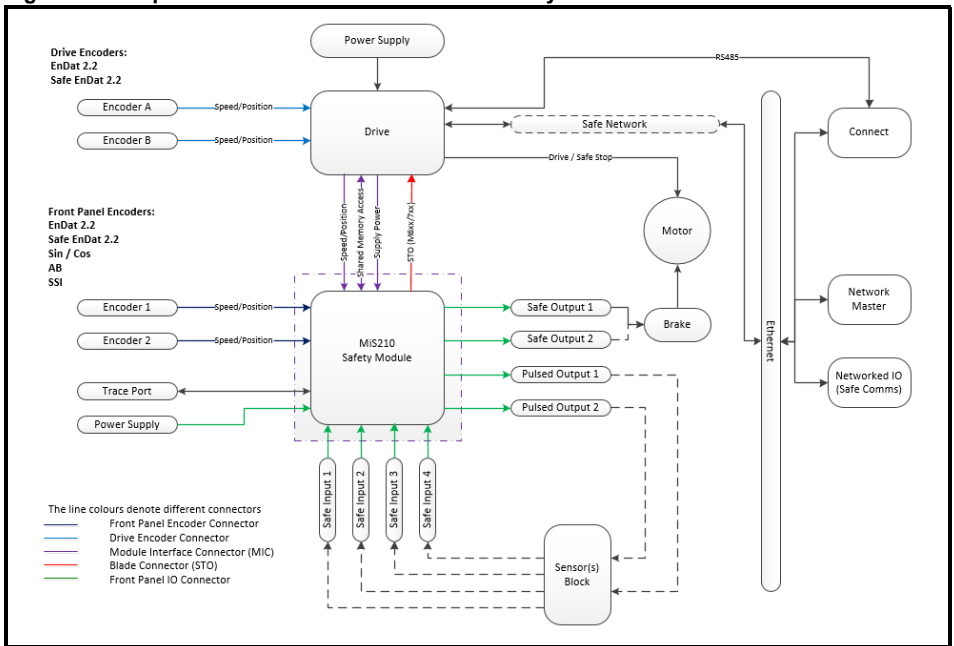

The MiS250 has only one difference to the MiS210, it does not have the direct connection, via the blade, to the Drive STO as shown in red.

The specific Key Technical Safety Indicators can be found in section 10 *Key Safety Data* on page 227.

Information
Introduction
Technical Safety Features
Installation
Connect Configuration Tool Introduction
Start Up
Validation
Motion Safety Function Details
Diagnostics and Maintenance
Key Safety Data
Version Control (Amendments)



**WARNING**

- When using several sensors with different functions (e.g. position indicator, access door plus speed recording) for a safety system, these must be included as an inline circuit in any technical safety assessment of the complete system.
- Due compliance with safety specifications and EMC directives is mandatory
- With regard to the fault exclusions made, reference is made to the Tables listed under D in the Annex to ISO 13849-2.

The resultant maximum possible Performance Levels defined in ISO 13849 remain dependent on the following factors for external components:

- Structure (simple or redundant)
- Detection of faults with a common cause (CCF)
- Diagnosis coverage level on request (DCavg)
- Time until dangerous failure of a channel (MTTFd)

### 3.1 Digital IO

There are four Local Digital Input Pairs (1oo2 arrangement) providing a method of failure detection of a single input by comparison of the input pair. There are two Local Outputs that can be wired to external equipment as well as two Pulsed Outputs which are used in conjunction with the Local Inputs for enhanced diagnostics.

When a MiS210 Safety Module is fitted on M600, M700, M701, M702, HS70, HS71 or HS72 the Safe Torque Off is routed directly to the drive and removes the torque generated by the motor by disabling the drive power circuitry when a safe state is required. No external wiring is required for this.

When a MiS250 Safety Module is fitted on M750, M751 or M753 there is no direct STO connection, and a Safe Output must be wired from the MiS250 Safety Module to the Drive STO connection. A Cable is provided for this (section 4.5)

### 3.1.1 Diagnostic coverage for inputs

The MiS2x0 Safety Module has four paired inputs, each input comprises of two input lines, input A and B (paired). The four paired lines are continuously read by the MiS2x0 Safety Module to determine the state of each input pair.

**Table 3-1 Local digital input diagnostics - default**

MEASURE	DC <sub>avg</sub>	COMMENT
The test temporarily isolates the input circuitry from the input lines, mimicking a low voltage input – logical zero. The resulting values read by the processor confirm that each input switches to a logic zero. The diagnostic coverage does not incorporate the initial conditioning / protection components.	99.83 %	The failure of an internal component will result in either disconnection of the input from the external equipment, short circuit to ground within the MiS2x0 Safety Module or continuous high or a continuous low, or no effect on operation. In the case of a disconnection or the short circuit to ground or the continuous low the MiS2x0 Safety Module input will become a logic zero. For all input configurations a continuous low on one input of the pair will always result in the safe state but it will not cause a trip until the other input of the pair becomes high. If the input is continuously high the continuous tests will detect the fault and put the MiS2x0 Safety Module into a safe state.
The paired Inputs are validated against each other. The two channels of the input pair are treated differently, input A is conditioned and passed to the microcontroller, input B is conditioned and inverted and then passed to the microcontroller.		The two signals are compared by the MiS2x0 Safety Module software and only valid combinations of input A and B are accepted. The inputs are read every 1 ms and checked for a valid combination, if there is an invalid combination the outputs will be put in the safe state.

The above diagnostics cannot detect short circuits to +24 V or between the inputs thus greater input signal integrity can be achieved by configuring the MiS2x0 Safety Module to produce pulsed outputs and feed them through to the Input pairs. The pulsed outputs are in anti-phase and toggle their value every 1 ms. The MiS2x0 Safety Module monitors the inputs for pulses, absence of pulses due to the equipment safety device being triggered and when detected the required action taken.

**Table 3-2 Local digital pulse input diagnostics**

MEASURE	DC <sub>avg</sub>	COMMENT
The paired Inputs are validated against the pulsed output phase and each other for the correct state every 1 ms.	99.99 %	When used, the two pulsed outputs are in antiphase and the processor checks for the correct phasing at the input pairs. The pulsed inputs toggle each 1 ms. When the pulses are disconnected the microcontroller expects input A to be a zero and input B to be a one at the pin of the microcontroller. Deviations from these patterns are considered as a failure in the input and the MiS2x0 Safety Module will revert to a safe state.



- For a technical safety assessment of the input subsystem, manufacturer's data (MTTFd, FIT figures etc.) need to be incorporated.
- The DCavg figures quoted in Table 3-1 and Table 3-2 need to be applied in a conservative manner, and the information in the comments section need to be accounted for in the safety system.
- Fault exclusions are permitted in accordance with the applicable standards.
- If several sensor systems are required to assure proper function of an individual safety function, always merge their partial values correctly in accordance with the selected procedure.
- Any PSU powering equipment that is connected to the MiS2x0 Safety Module must be PELV or SELV and referenced to the drive 0 V, to guarantee the voltage does not exceed 60 V under working or fault condition. Failure to observe this could cause a loss of the safety function by damage to the digital output circuit.
- Any external equipment connected to the MiS2x0 Safety Module inputs must comply with IEC 61131-2.

### 3.1.2 Diagnostic coverage for outputs

The MiS210 Safety Module has three Safe switched Outputs (two Safe Outputs and one Integrated STO), for use in safety related functions. Each output can be controlled individually or grouped.

The MiS250 Safety Module only has 2 Safe switched Outputs as it does not have the integrated STO.

The operation of each output is continuously tested during operation.

**Table 3-3 Local digital output diagnostics**

MEASURE	DC <sub>avg</sub>	COMMENT
The output is monitored checking its state and operability (it is periodically switched low for a period of 500 μs)	99.99 %	If the output is stuck in operational mode due to a failure within the MiS2x0 Safety Module the power will be removed resulting in a safe state. <b>NOTE</b> Output protection devices are not covered by the diagnostics



- Tests should be carried out at regular intervals. E.g. at the start of every shift or once a week as deemed necessary. In any event a test must be carried out at least once every year.
- Any PSU powering equipment that is connected to the MiS2x0 Safety Module must be PELV or SELV and referenced to the drive 0 V, to guarantee the voltage does not exceed 60 V under working or fault condition. Failure to observe this could cause a loss of the safety function by damage to the digital output circuit.
- Any external equipment connected to the MiS2x0 Safety Module outputs must comply with IEC 61131-2.
- A range of diagnostic measures have been implemented for the output system. Customers should be aware of the need to incorporate circuit reinforcement elements such as relays, contactors etc. in the disengagement circuit.
- For a technical safety assessment of the output subsystem (when using external elements in the disengagement circuit, e.g. to reinforce the circuit), the manufacturer's specifications (MTTFD, FIT figures etc.) must be used.
- The DC<sub>avg</sub> figures quoted in the table need to be applied in a conservative manner, and compliance with parameters (see Table 3-3 Comments Column) needs to be assured.
- Fault exclusions are permitted in accordance with the applicable standards. Compliance with the parameters listed here must be assured at all times.

## 3.2 Encoders

On the MiS2x0 Safety Module there are four possible encoder connections, two via the drive (Channel A and Channel B) and two on the MiS2x0 Safety Module's Front Panel, known as local (Channel 1 and Channel 2). Only certain combinations of encoder are possible, and these are detailed in the following tables. A maximum of two encoders can be used with the MiS2x0, the purpose being to facilitate achieving a higher SIL using a second encoder to verify the first encoder and detect slip between the encoders which would be indicative of an encoder coupling failure.

Relative encoders typically provide either a pulse train, or a pulse count. Each pulse represents a measure of distance (angular or linear). The number of pulses between two readings allows the distance moved to be derived and the speed at which the equipment is moving. Additionally, acceleration can be derived from multiple readings of the encoder.

Absolute encoders typically provide a value which represents the current position of the equipment the encoder is attached to. Hence by comparing two samples of the positional information, the speed can be derived. Additionally, acceleration can be derived from multiple encoder readings.

There is a risk of mechanical shaft failure that cannot be detected; thus, a positive shaft connection is essential. To gain a better diagnostic, the encoder power supplies can be monitored, see section 3.2.1.

The encoders and the associated SIL identified in the table are indicative only. Some encoder manufacturers may claim a greater SIL than that indicated in the table below. The encoder datasheet should be consulted and read in conjunction with this manual to determine if the diagnostic measures taken by the MiS2x0 Safety Module are sufficient to achieve the required SIL. In some additional hardware measures are required, such as a second encoder, to reach the higher SIL. To make system certification as simple as possible it is advised to use SIL rated encoders.

**Table 3-4 Local encoders only**

Primary Encoder		Secondary Encoder		Achievable SIL
Type	Location	Type	Location	
Safe Endat 2.2	Channel 1			3
Endat 2.2	Channel 1			2
AB	Channel 1			1
Sin Cos	Channel 1			1
SSI	Channel 1			1
Endat 2.2	Channel 1	AB	Channel 2	3
Endat 2.2	Channel 1	SSI	Channel 2	3
Endat 2.2	Channel 1	Sin Cos	Channel 2	3
AB	Channel 1	SSI	Channel 2	3
SSI	Channel 1	AB	Channel 2	2
Sin Cos	Channel 1	AB	Channel 2	3
AB	Channel 1	Sin Cos	Channel 2	2
Sin Cos	Channel 1	SSI	Channel 2	3
SSI	Channel 1	Sin Cos	Channel 2	2
Sin Cos	Channel 1	Sin Cos	Channel 2	2
AB	Channel 1	AB	Channel 2	2
SSI	Channel 1	SSI	Channel 2	2

**Table 3-5 Drive encoders only**

Primary Encoder		Secondary Encoder		Achievable SIL
Type	Location	Type	Location	
Safe EnDat 2.2	Channel A			3
Endat 2.2	Channel A			2
Endat 2.2	Channel A	Endat 2.2	Channel B	3

**Table 3-6 Encoder combination (Drive and local)**

Primary Encoder		Secondary Encoder		Achievable SIL
Type	Location	Type	Location	
Endat 2.2	Channel A	Endat 2.2	Channel 2	3
Endat 2.2	Channel A	SSI	Channel 2	3
Endat 2.2	Channel A	Sin Cos	Channel 2	3
Endat 2.2	Channel A	AB	Channel 2	3

Channel A is known as P1 on the Drive, and Channel B is known as P2.

SinCos - Endat encoders are not supported by the MiS2x0 and if this type of encoder is used then it can only be connected to the MiS2x0 using the splitter cable described in section 4.5 and treated as a SinCos Local Encoder.



- If Encoder Snooping is required on Digitax, then the Drive Firmware needs to be V01.23.00 or greater

### 3.2.1 Diagnostic coverage for encoders

The MiS2x0 Safety Module supports the use of two encoders which may be connected to the MiS2x0 Safety Module via either the front panel or via the Host drive, or a combination of the two. In the case where a single Safe EnDat 2.2 encoder is used, a second encoder is not required and cannot be used because the safe encoder will provide two independent position measurements over the same communications path.

The following table provides a description of the encoder type and a summary of the diagnostic coverage provided by the MiS2x0 Safety Module. The majority of the diagnostic coverage is provided by the software reading the hardware data and determining the validity of the hardware signals provided. The operation of each encoder input is continuously tested during operation.

The encoder type(s) used determines the diagnostic coverage that can be achieved.

**Table 3-7 Encoder diagnostics**

MEASURE	DC <sub>avg</sub>	COMMENT
<b>SIN COS (Analogue):</b> Two differential analogue signals, each pair being a sinusoid with a 90 degrees phase shift between the signal pairs. The sinusoids provide the encoded position reported by the encoder and the direction of travel. The frequency of the sinusoids is dictated by the rate of movement. The MiS2x0 Safety Module does not use the magnitude of the signals for calculating the fine position, it counts the number of cycles per 1ms period to extract a value of speed.		
The phase relationship between the two differential signals means that the expression $1 = \sin^2 + \cos^2$ can be used to confirm that the two signals have the correct relationship and are therefore operational. The MiS2x0 Safety Module performs the trigonometric invariance diagnostic test; this involves checking the phase/amplitude relationship between the two differential signals conforms to $1 = \sin^2 + \cos^2$ .		Loss of both signals will cause a detected failure.
The speed evaluation uses both inputs to determine the speed and direction of the equipment to which the encoder is attached.		Loss of one signal, will result in the reported speed being zero, one or minus one (average of zero), and cause the diagnostic test to fail.
<b>AB:</b> Produces two Phase shifted pulse trains, each pulse indicates a measure of distance, and the direction can be determined from phase relationship between the two pulse trains.		
The differential amplitude of the AB encoder signals is measured.		Loss of both signals will cause a failure.
The speed evaluation uses both inputs to determine the speed and direction of the equipment to which the encoder is attached. Loss of both or one signal will result in the speed measurement producing an average speed of zero.		Loss of one signal, will result in the reported speed being zero, one or minus one (average of zero), and cause the diagnostic test to fail.
<b>SSI:</b> Provide position data, the data length varies and are typically encoded using Gray Code. The MiS2x0 Safety Module produces a clock which the encoder uses to latch the position and clock out data bits onto the data line. This is a simple serial interface which is driven by the MiS2x0 Safety Module microcontroller.		
The differential amplitude of the encoder clock and data signals are measured.		A loss of signal will cause the MiS2x0 Safety Module to revert to a safe state.
No data returned		A loss of signal will cause the MiS2x0 Safety Module to revert to a safe state.
<b>EnDat 2.2:</b> Provide position data from two internal encoders. The data length varies depending on the encoder model. The MiS2x0 Safety Module produces a clock and sends a command. The encoder responds to the command with the required data with a CRC for the data. The data from the Safety EnDat 2.2 encoder depends on the command sent. In normal operation position data is returned from the encoder with encoder health status information and CRC.		

Encoder status data is examined to ensure the encoder is operational.		Encoder status indicating an error will cause the MiS2x0 Safety Module to revert to a safe state.
The CRC passed with the data is verified for every message.		An invalid CRC will cause the MiS2x0 Safety Module to revert to a safe state.
<b>Safe EnDat 2.2:</b> Provide position data from two internal encoders. The data length varies depending on the encoder model. The MiS2x0 Safety Module produces a clock and sends a command. The encoder responds to the command with the required data with a CRC for the data. The data from the Safety EnDat 2.2 encoder depends on the command sent. In normal operation position data is returned from the encoder with encoder health status information and CRC.		
Encoder status data is examined to ensure the encoder is operational.		Encoder status indicating an error will cause the MiS2x0 Safety Module to revert to a safe state.
The CRC passed with the data is verified for every message.		An invalid CRC will cause the MiS2x0 Safety Module to revert to a safe state.
The encoder provides position from two internal encoders. The primary encoder provides data on every request, whereas the secondary encoder provides data over four cycles. The data is aligned with the first primary encoder reading of the four cycles. The two encoder positions are scaled (if required) and compared.		Failure of the encoder comparison, will cause the MiS2x0 Safety Module to revert to a safe state.
The Heidenhain specific test looks at the movement of the encoder and compares the read position with a maximum / minimum expected position.		Failure of the Heidenhain test, will cause the MiS210 Safety Module to revert to a safe state.
Overall MiS2x0 DC Avg for Encoder Diagnostics.	<b>99.83 %</b>	

The operation of the drive encoder interface is fundamentally different to the local interface. For encoders connected to the local connector the MiS2x0 Safety Module operates as the encoder interface master, providing the clocks and commands. In the case of the drive encoder interface the drive is the master and provides the encoder clock, and commands. The MiS2x0 Safety Module performs the same checks as with the local encoder.

**Table 3-8 Encoder specific tests**

Test Name	Description	SIN COS	AB	SSI	ENDAT 2.2	SAFE ENDAT 2.2
Trigonometric Analog Test	Check trigonometric invariance via encoder signal monitoring.	Yes				
Digital Counter Test	One error counter based on simultaneous changes for Sin and Cos signal at the same sample.	Yes	Yes			
Transfer Test	One packet flag is provided in order to guarantee the transfer of data between the encoder and the microcontroller.	Yes	Yes	Yes	Yes	Yes
Comparison Test*	Primary Encoder Value compared with Secondary Encoder Value.	Yes	Yes	Yes	Yes	Yes**
Differential Analog Test	Sample of the true amplitude of the Differential Signals to check if is within range.		Yes	Yes		
EnDat CRC	CRC checked protocol, 2 consecutive failures needed to report an error.				Yes	Yes
Heidenhain Test	Specific safety algorithm as specified by Heidenhain.					Yes

\* Only if a second encoder is connected.

\*\* SafeEndat provides two encoder positions from two encoders within a single device.

Additionally, the internal encoder PSU and a single external Encoder PSU can be monitored (Internal means from within the MiS2x0 Safety Module and external is outside of the MiS2x0 Safety Module). It is expected that one encoder is powered directly from the internal encoder PSU in the MiS2x0 Safety Module via the local connection. Both the internal and external encoder power supplies can be set at 5 V, 8 V or 15 V and this is configured in Connect. Tests are performed for Over Voltage, Under Voltage as well as a self-test of the monitoring circuits.

**Table 3-9 Encoder power supply tests**

	Lower Limit	Upper Limit
Internal / External Encoder PSU 5 V	4.6 V	5.8 V
Internal / External Encoder PSU 8 V	7.14 V	9.3 V
Internal / External Encoder PSU 15 V	13.19 V	17.01 V



- Tests should be carried out at regular intervals. E.g. at the start of every shift or once a week as deemed necessary. In any event a test must be carried out at least once every year.
- Any PSU powering equipment that is connected to the MiS2x0 Safety Module must be PELV or SELV and referenced to the drive 0 V, to guarantee the voltage does not exceed 60 V under working or fault condition. Failure to observe this could cause a loss of the safety function by damage to the digital output circuit.
- The encoder interface shall comply with the RS-485 electrical standards operating from a supply of 3.3 V
- The DC<sub>avg</sub> figures quoted in the table need to be applied in a conservative manner, and compliance with parameters (see Table 3-7 Comments Column) needs to be assured.
- Fault exclusions are permitted in accordance with the applicable standards. Compliance with the parameters listed here must be assured at all times.

**3.2.2 Encoder Mathematics**

The MiS2x0 Safety Module provides safety functions that may require position, speed and/or acceleration information from a variety of encoders. The encoder interface is provided by the microcontroller embedded within the MiS2x0 Safety Module. The Microcontroller is configured with information from the user when the MiS2x0 Safety Module is configured using Connect.

**Encoder Configuration Parameters**

- Encoder Parameters : - Encoder Type and Data Format
- Encoder Averaging Period : - Selected Average Period of Reported Speed.

**Resulting Data Output: -**

- Position
- Speed
- Acceleration
- BIT Data

The position data will be a positive number indicating the position reported by the encoder and will not be extended to count the number of times the encoder wraps round as the system position changes. Speed and acceleration correct for wrap round.

The speed data representation is in increments per second.

**NOTE**

- The encoders are sampled at 1 kHz, hence the values are scaled to units relative to a one second interval.

**3.2.2.1 AB or Sin Cos encoder interface rules**

AB and SinCos encoders are relative encoders, with each pulse counted representing a unit of distance. The microcontroller captures the edges of the pulses on each signal and increments or decrements a counter dependent on the detected direction. ("A" leading "B" results in an incrementing count). At power up the encoder counter is set to zero.



The maximum pulse rate that can be reliably captured is 350 kHz. If this is exceeded, then there is a risk of incorrect speed reporting and this **MUST** be analyzed by the System Safety Engineer.

**WARNING****Position**

1. A counter representing position relative to 0 at power up, wraps between 0 and  $2^{25}-1$ .

**Speed**

2. The speed is the difference between the current encoder reading and the previous encoder reading, and the sign indicates the direction of movement. An average can be applied to improve Speed Resolution, see section 3.2.2.3.
3. The microcontroller takes account of the wrap condition of the fundamental counter.

**Acceleration**

4. The acceleration is determined by the difference between the current speed and the previous speed then multiplied by 1000000. A positive value indicating acceleration and a negative value indicating a deceleration.

**3.2.2.2 Digital position encoder interface rules**

There are three types of encoder to be considered, SSI, EnDat 2.2 and Safe EnDat 2.2 which is a variant of the EnDat 2.2.

These encoders may provide either relative position or absolute position. The MiS2x0 Safety Module has no knowledge of how the encoder data / system is configured in terms of absolute or relative position. The system designer must ensure that the design accommodates the mode of operation appropriately by the selection of the correct encoder and the design of the MSFs.

All of these encoders follow the same method for relative measurements.

Each encoder provides a position value which is captured by the microcontroller once every 1 ms. The MiS2x0 Safety Module needs to know the data length in terms of bits per revolution and the number of bits indicating the number of rotary turns. In the case where SSI encoders are used the user needs to indicate if "Gray Data" or simple Binary data is provided. These are set in Connect during the configuration of the Encoders.

When a linear encoder is in use the encoder position length should be entered as the Comms Bits and the rotary turn bits should be set to zero.

**Position**

1. The position data is displayed in a 64-bit signed word that cannot go negative.



The encoder position should not change by more than a third of the encoder range within a 1 ms period. This is essential if the MiS2x0 is to determine direction and speed correctly.

**WARNING**

**Speed**

- The speed is the difference between the current encoder reading and the previous encoder reading, and the sign indicates the direction of movement. The Microcontroller takes care of encoder wrap when calculating the speed from the reported position data provided the reported position has not progressed by more than a third of the range of movement since the last position reading. An average can be applied to improve Speed Resolution, see section 3.2.2.3.
- The value obtained for the speed is multiplied by 1000 to get the speed in counts per second.

**Acceleration**

- The acceleration is determined by the difference between the current speed and the previous speed then multiplied by 1000000. A positive value indicating acceleration and a negative value indicating a deceleration.

**3.2.2.3 Speed resolution**

An averager (using an arithmetic mean with a user configurable sample size) is used to improve the speed resolution at the expense of response time (not including the maximum 3 ms response time) to envelope breaches.

The size in counts per second of the speed resolution (Qsize) is determined by the sample size:  $QSize = 1000/N$  where QSize is the speed resolution in counts per second, N is the sample size. The sample size range is 1 to 100, see table below. The maximum response delay to an envelope breach is the sample size in ms. The sample size is set in Connect as part of the Encoder configuration.

**Table 3-10 Sample size examples**

Sample Size	Speed Resolution (counts per second)	Worst Case Response (ms)	Encoder (8192 count/rev) shaft speed (RPM)
1 (min.)	1000	1 ms	7.32
4 (default)	250	4 ms	1.83
100 (max.)	10	100 ms	0.0732

**3.2.2.4 Use of encoders in absolute measurement systems**

The MiS2x0 Safety Module includes motion safety functions that require position information. To achieve this the encoder and system design should comply with the following statements:

- For position measurement the range of the encoder must encompass the full range of movement of the equipment. In the case of relative encoders (Sin Cos and AB) the range is  $2^{25}$  encoder counts.
- The position reported by the encoder at any point is unique for the entire range of movement.
- The position reported by the encoder must be repeatable i.e. a given point in the range of motion is always reported as the same position by the encoder and is true before and after a power cycle. If relative encoders are used a datum sequence is required which negates the need for the position reported by the encoder to be the same after a power cycle.



If the above is not respected the MiS2x0 Motion Safety Functions which require position data will not operate correctly

**WARNING**

The MiS2x0 Safety Module does not distinguish between absolute or relative position. The MiS2x0 Safety Module will test its configuration to determine if position functions are required, and if so will reject configurations without an encoder configuration.

**NOTE**

Variants of EnDat and SSI encoders provide absolute position, and it is up to the user to ensure an appropriate encoder is attached.

### 3.2.3 Drive encoder interface (EnDat 2.2 and Safe EnDat 2.2)

The Drive Encoder interface allows the MiS2x0 Safety Module to snoop the clock and data lines between the encoder and the drive to obtain encoder data. There are two encoder types supported using this mechanism, EnDat 2.2, and SafeEnDat 2.2. The MiS2x0 Safety Module listens to the data exchange between the Drive and the encoder, listens to each command the drive sends to the encoder, decodes the command and when appropriate snoops the data received from the encoder.

#### 3.2.3.1 Transmission delays

The clock signal and the command sent to the encoder are synchronized hence the clock signal can be used directly by the encoder. However the returned data can have a significant transmission delay relative to the transmitted clock. For example if the cable to the encoder is 100 m the delay between the transmission of the clock and data and the receipt at the encoder is in the order of 0.6  $\mu$ s, and the returned data has a total delay in the order of 1.2  $\mu$ s at the drive relative to the transmitted clock.

The MiS2x0 can compensate for a maximum delay of 2  $\mu$ s.

When using the approved Heidenhain cables, the cable lengths should be restricted to 100 m at 2MBaud Drive Snooping and 50 m at 4MBaud Drive Snooping.

**NOTE**

- Excessive Transmission Delay has a detrimental effect on the MiS2x0 Safety Module's ability to recover the data from the encoder.
- The conversion time for the encoder needs to be taken into account when selecting the encoder to be used.

### 3.2.4 Local encoder interface (EnDat 2.2, Safe EnDat 2.2 and SSI)

The MiS2x0 Safety Module can receive data from EnDat2.2, Safe EnDat2.2 or SSI via its front panel interface at the rates indicated below.

**Table 3-11 Baud rate Vs Cable length**

Baud Rate	Safe EnDat 2.2	EnDat 2.2	SSI
520 kHz	63 m	63 m	63 m
390 kHz	90 m	90 m	90 m
312 kHz	104 m	104 m	104 m
223 kHz	150 m	150 m	156 m
104 kHz	Not available	150 m	383 m

The data exchange between the MiS2x0 should complete within 1 ms. Hence the maximum duration of the data exchange should be verified using the selected baud rate and the message format. The total data exchange duration can be calculated using the formulas contained in Table 3-12 below.

**Table 3-12 Data Length Analysis**

Protocol	Time for Full Position	Time for Complete Data Exchange
EnDat 2.2	$t_{ST} + t_D + 10T + 3T + NtT + 5T + t_{Add}$ where $t_{cal} \leq t_{ST} + t_D/2 + 10T$ $t_{ST} + t_D + t_{cal} + 3T + NtT + 5T + t_{Add}$ where $t_{cal} > t_{ST} + t_D/2 + 10T$	Time for full position + $t_m$
SSi	$tD + T + NtT$ (tD can't be measured, so a value of 1.25 $\mu$ s is used)	Time for full position + $t_m$

Where:

$t_{ST}$  is EnDat start time

$t_D$  is Transmission delay from the front panel to the encoder and back

T is 1/baud rate

$T_{cal}$  is Position calculation time

Nt is Total number of position information bits

$t_m$  is Encoder recovery time

$t_{ADD}$  is Additional data from the Safe EnDat 2.2 / EnDat 2.2 encoder is used during the MiS2x0 Safety Module configuration checks performed prior operating. The additional information is used to receive the second position from the Safe EnDat 2.2 and is 30-bit times in length. The Additional data is not used by the MiS2x0 Safety Module during operation when connected to an EnDat 2.2.

### 3.2.5 Cable attenuation (EnDat 2.2, Safe EnDat 2.2 and SSI)

The attenuation characteristics of the cable reduces the amplitude of the high frequency components of the transmitted data. This has the effect of rounding the edges of the data signals and reducing the amplitude of the signals that represent alternating 1 s and 0 s. Cable lengths should be minimized as far as possible to reduce these effects, and where long cables are unavoidable only suitable low loss cables should be used. The effects of cable attenuation should be considered alongside the effects of cable delays to arrive at an appropriate cable type.

### 3.2.6 AB and Sin/Cos encoder interface

These encoders are connected to the MiS2x0 Safety Module front panel and provide signals to the MiS2x0 Safety Module in sympathy with the system they are attached. The effects of cable delays are discounted because the delays on the two signals are equal. However, there is a limitation in the signal frequency that can be interpreted by the MiS2x0 Safety Module.

**Table 3-13 Maximum frequency**

Encoder Type	Maximum Frequency of Fundamental
AB	350 kHz
Sin/Cos	350 kHz

The attenuation characteristics of the interface cable used reduces the amplitude of the high frequency components of the transmitted data. This has the effect of rounding the edges of the data signals and reducing the amplitude of the signals that represent alternating 1 s and 0 s. Cable lengths should be minimized as far as possible to reduce these effects, and only suitable cables should be used.

### 3.2.7 Process encoder values

This aspect of the MiS2x0 Safety Module allows the data from two separate encoders to be compared, verifying the operation of the primary encoder against the secondary encoder.

Initially taking the difference between the reported positions from the two encoders. Then making sure that the difference does not vary by more than a tolerance, "Difference Tolerance".

Scaling values are required to be set (Encoder Ratio Numerator and Encoder Ratio Denominator) so as encoders with different resolutions can be compared. These values are applied to the secondary encoder in the following way:

Scaled Encoder = (Secondary Encoder Reading \* Encoder Ratio Numerator) / Encoder Ratio Denominator

Consider the following example:

Primary Encoder = 4096 Pulses per Revolution

Secondary Encoder = 1024 Pulses per revolution

To perform the scaling, the denominator is set to 1 and the numerator set to 4.

Scaled Encoder = (1024 \* 4) / 1 = 4096

The Difference Tolerance is relative to the primary encoder and must take account of the difference in encoder resolutions. In the case above the primary encoder will count in units whereas the secondary encoder will increment in increments of 4 once every 4 counts of the primary encoder. Hence to avoid a trip due to a difference tolerance it will need to be set to a minimum of 4. Additionally, the Difference Tolerance must take account of encoder non linearities, and if the encoders are attached by a mechanical gearbox, the gearbox backlash.

#### **Systems with gearing between the two encoders:**

In this example we will look at a system which contains a gearbox with a ratio other than 1:1 to demonstrate the setup of the MiS2x0 dual encoder feature. The primary encoder is mounted on the motor shaft which directly drives the input shaft of a gear box. A secondary encoder is mounted on the output shaft of the encoder. Both encoders have the same direction of travel.

The Primary Encoder on the motor has a resolution of 32 Pulses per Revolution

The gearbox has a ratio of 51.41 rotations of the input shaft to 1 rotation of the output shaft

The Secondary Encoder mounted on the output shaft of the gearbox and has a resolution of 2048 Pulses per Revolution

To avoid issues with rounding errors we need to translate the gearbox ratio into whole numbers. This can be easily achieved by multiplying both sides of the gearbox ratio by 100. This results in a gearbox ratio of 5141 to 100.

Introducing the encoders, we simply take the resolution of each and multiply by the gearbox ratio to find the ratio between the reported distances of the encoders.

The number of counts on the input = 32\*5141 = 165512 which equates to the number of counts on the output of 100\*2048 = 204800.

These numbers can be reduced by considering the relationship between the two encoders. The ratio between the encoders is 2048/32 is 64, hence the above can be reduced to a ratio of -

1\*5141 = 5141 to 100\*64 = 6400 i.e. 5141:6400

Our denominator is set to 6400 and the numerator is set to 5141

Hence to scale the secondary reading: -

Scaled Encoder = (2048\*5141)/6400 = 1645.12

Information
Introduction
<b>Technical Safety Features</b>
Installation
Connect Configuration Tool Introduction
Start Up
Validation
Motion Safety Function Details
Diagnostics and Maintenance
Key Safety Data
Version Control (Amendments)

For 1 revolution of the output encoder the scaled position is 1645.12 which equates to the Primary Encoder \* the gear ratio:  $- 32 * 51.42 = 1645.12$

The Difference Tolerance is relative to the primary encoder and must take account of the difference in encoder resolutions. In the case above as the primary encoder counts in units whereas the secondary encoder will increment by  $(6400/5141) 1.244$  counts. Hence to avoid a trip due to a difference tolerance it will need to be set to a minimum of 1. Additionally, the Difference Tolerance must take account of encoder non linearities, and if the encoders are attached by a mechanical gearbox, the gearbox backlash.

### 3.3 Embedded microcontroller and support devices

The MiS2x0 Safety Module embedded microcontroller provides the physical platform for the execution of the application software. The selected processor has been assessed in accordance with IEC 61508 and based on the diagnostic features built into the device, it attained a SIL 3 rating when used with an external watchdog device also contained within the MiS2x0 Safety Module. The microcontroller hardware provides interfaces to, or internal hardware with the following functions:

#### 1. Local inputs

Facilitates the reading of the Local Inputs on which the configured safety functions act.

#### 2. Local outputs

Facilitates the writing of the Outputs based on the analysis performed by the configured safety functions.

#### 3. Encoder interface

Facilitates the reading of the attached encoders either attached to the front panel of the MiS2x0 Safety Module or the encoder signal routed through the drive to the MiS2x0 Safety Module.

#### 4. Shared memory access

Manages the communications via the Drive shared memory interface. A variety of protocols and error detection mechanisms are implemented in software, providing safe and secure communication. Via this interface the MiS2x0 Safety Module can gain access to an attached network and make use of safety protocols.

#### 5. Data processing

Provides the system manager and scheduler, processes the Encoder and Local Inputs, Motion Safety functions as specified by the user's configuration file, and sets the Local outputs.

#### 6. Storage functional block

Microcontroller Internal Memory with error detection.

#### 7. Safety diagnostics provides diagnostics for the following diagnostic features:-

- 7.1. Local Inputs – Monitoring and test inject
- 7.2. Local Outputs – Monitoring and test inject
- 7.3. Encoder Diagnostics – Signal Monitoring, and data validation
- 7.4. Power supply – Monitoring and Test Inject
- 7.5. Microcontroller Tests and checks – Power on and Continuous self-test.
- 7.6. Companion chip monitoring
- 7.7. Temperature Monitoring

### 3.3.1 Diagnostic coverage summary

**Table 3-14 Diagnostic coverage summary**

MEASURE	DC <sub>avg</sub>	COMMENT
In summary, the microcontroller contains two processing units whose operation is continuously compared and should a mismatch in operation be detected, the processors are halted, and the MiS2x0 Safety Module is forced into a safe state. The memory which supports the processor has a multibit check code for each location to guard against memory corruption. The peripherals contained on chip are also subject to a varying degree of test - depending on the complexity of the interface, ranging from parity to CRC. To support memory checking / message checking the microcontroller has a built-in 64-bit CRC engine which is used continuously verifying program memory.	99.74 %	This figure considers the embedded microcontroller and the support devices required for operation.

## 3.4 Response times

Response time is an important technical safety property and needs to be taken into account with every application / application based or applied safety function.

 <b>WARNING</b>	<p>Particular caution is advisable when using filter functions. Depending on filter length and time, the response time can be extended substantially and this fact should always be taken into consideration when configuring the technical safety functions.</p> <p>The maximum Drive STO Response time is 20 ms.</p>
--	--

The Local Response time is defined to be the time between a change of state of an input at the boundary of the MiS2x0 Safety Module and corresponding change of state of an output at the boundary.

The cycle time of the MiS2x0 Safety Module is 1 ms, the default response time is less than 4 ms, but this can vary depending upon the Speed Averaging Filter and the Input Filter, see section 3.2.2.3 and section 8.25.

The MiS2x0 Safety Module runs a substantial amount of self-test at both power on and continuously. The complete self-test suite is completed every 16ms.

When the MiS2x0 Safety Module enters the commissioning testing state it has a time limit placed on it to prevent the unit being used in a "test" state for an indefinite amount of time. This is set by the user in Connect and is a maximum of 25 days.

### 3.4.1 Networks

The response time of network communications cannot be given as it will depend upon the specific network in question, size, loading etc.

EtherNet/IP™



The MiS2x0 Safety Module should not be used for Safety Applications involving CIP Safety™ where the drive on board Ethernet is less than version V02.11.00.16 (to ensure the on-board Ethernet is compatible check parameter 04.02.18 and ensure CIP Safety option is available

The MiS2x0 Safety Module CIP Safety stack, with CIP Product Revision Number V01.02, has been certified as CIP Safety compliant with the following version of the on-board Ethernet, V02.11.00.16.



The MiS2x0 Safety Module should not be used for applications involving Safety over EtherCAT® (FSoE) where either the drive on-board EtherCAT® or the user fit SI-EtherCAT is less

than version V01.07.04.02 as this is the version that has been certified as being compliant to the FSoE standard.

When implementing an FSoE network the user should consider the System Requirements detailed in Section 9 of ETG5100. This section details the electrical requirements, the system function response times, determination of the FSoE watchdog time and the Constraints for the calculation of the system characteristics. section 3.4 of this manual provides the response times for the MiS2x0 which will influence the system response times.

There is no restriction on the Network topology, but the performance of the Black Channel is dependent on the design of the whole network that carries it and predictions about performance cannot be made, and performance could vary.

Any change to the installed system can cause changes to the performance of the Black Channel including addition of or changes to other modules on the network including new firmware versions. If any such changes are proposed, then an impact analysis should be performed and if required the Black Channel performance should be retested and the appropriate maintenance control measures applied.



**WARNING**

- The MiS2x0 Safety Module **MUST NOT** be used in marine vehicles without permission from the stack licensor, this is a restriction imposed by ODVA the owner of the CIP Safety protocol.
- The MiS2x0 Safety Module can only be paired with one PLC
- For CIPsafety the PLC cannot use multicast to communicate to the MiS2x0 as MiS2x0 does not support multicast operation.
- The Network Safety Communications should be turned off while downloading a Safety Configuration to the MiS2x0.

EtherCAT® and Safety over EtherCAT® are registered trademarks and patented technologies, licensed by Beckhoff Automation GmbH, Germany

EtherNet/IP™ and CIP Safety™ are trademarks of ODVA, Inc.

Information
Introduction
<b>Technical Safety Features</b>
Installation
Connect Configuration Tool Introduction
Start Up
Validation
Motion Safety Function Details
Diagnostics and Maintenance
Key Safety Data
Version Control (Amendments)

---

## 4 Installation

---

### 4.1 General installation notes

Always follow the safety instructions during installation.

The module must be installed in an IP54 or greater rated enclosure.

Route all signal cables separately for activation of digital inputs and contact monitoring purposes.

In all cases separate Non ELV voltages from ELV, SELV and PELV lines, if these voltages are being used in conjunction with this application.

Cable lengths for digital inputs and outputs should not exceed 30 m. Where cable runs exceed 30 m, take appropriate action to exclude the possibility of faults resulting from un-authorized overvoltage levels. Such action may include avoidance of lightning conductors on external wiring, overvoltage ('spike') protection in internal areas, protected cable routing, i.e. shielding.

The encoder PSU cable should be shorter than 30 m and should not leave the building and should not be connected to a distributed power network.

#### Measures relating to electromagnetic compatibility (EMC).

The MiS210 Safety Module is intended for use in a Unidrive-M600, M700, M701, M702, HS70, HS71 or HS72 environment and the MiS250 Safety Module is intended for use in a Digitax M750, M751 or M753 environment. The environments comply with the EMC requirements provided the module is installed as per the instructions in this manual.



- All signal wires (IO, encoder etc.) connected to the MiS2x0 Safety Module must be enclosed in shielded cables and the shield of the cable connected to 0 V of the MiS2x0 Safety Module (via a short wire) **AND** the earthed A frame of the Unidrive. The preferred connection method to the A frame is to remove the outer insulation of the shielded cable and then tie the cable to the A frame with a cable tie so that the exposed shield makes direct contact with the A frame.
- If there is not a direct connection between the A-frame and one of the drive's 0V terminals (i.e. not MiS2x0) then a short wire connection between a 0V terminal on the drive's IO port and the A-frame must be made. The direct connection between the A-frame and one of the drive's 0 V terminals is often provided by a screened cable going to the drive's IO terminals or encoder port.
- When using an Encoder Power Supply Splitter cable with or without Sin Cos the shielded connector connecting to the encoder cable should be bonded to earth e.g. the backplane the drive is mounted upon.

It is a prerequisite that the entire system and components conforms to the EMC Directive. The user is responsible for the installation and configuration of the MiS2x0 Safety Module and must be a competent safety engineer as they need to ensure that the function specified in the configuration is correct for the application needs.



- Refer to the drive manual for details on power cabling routing and protection.
- Always use shielded cabling when connecting position/speed sensors. The cable used to transmit signals must be compatible with the RS-485 standard (twisted pair wiring).
- Ensure that all the inverter technology installed in the vicinity of the module is EMC compliant. Pay careful attention to the cable routing and the processing of shielding for the motor wire and connection of the brake resistor. Always ensure compliance with the installation guidelines of the inverter manufacturer.
- If the MiS2x0 is not a new and unused part, any existing configuration should be cleared before the device is used or connected onto a safety network. This can be done by performing a Factory Reset.
- If the MiS2x0 is to be connected to a Safety Network, carefully consider implications of mixing different SIL level devices on the Network.
- Do not change the configuration of the drive (this includes updating the Drive Firmware and downloading user programs to the drive or other option modules) or Reset the modules using Parameter 0.0 while the MiS2x0 is in Operating or Configuring Mode as this may result in a failure which will require a power cycle.

## 4.2 Mounting on the drive



- The module must be electrically isolated and have a disconnected power supply during installation work.
- The control circuits are isolated from the power circuits in the drive by basic insulation (single insulation) only. The installer must ensure that the external control circuits are insulated from human contact by at least one layer of insulation (supplementary insulation) rated for use at the AC supply voltage.
- When using a MiS250 on a Digitax ensure the Digitax 24 V Power Supply has a minimum current rating of 8 A.

### 4.2.1 MiS210 on M600, M700 (HS70), M701 (HS71) and M702 (HS72)

On these drives there are 3 option module slots available. The MiS210 Safety Module can only be connected in slot 3 as this provides the direct connection to the drive Safe Torque Off (STO) through the blade connector. Attempting to fit the MiS210 Safety Module into any other slot may cause physical damage to the module.

The MiS210 Safety Module checks that the Drive Software is greater than or equal to V01.16.00, as this is the minimum version that allows the drive encoders to be read.

To be compatible with the MiS210 Safety Module the following Drive Date codes are required:

- Drive Date Code must be greater than 1807 for M600, M700, M701 and M702
- Drive Date Code must be greater than 2117 for HS70, HS71 and HS72 up to Frame 9
- Drive Date Code must be greater than 2023 for HS70, HS71 and HS72 Frame 11 and 12

## 4.2.2 Physical connection

Place the front of the MiS210 Safety Module under the locating clip on the drive and then push down the blade, refer to MiS210 and MiS250 Safety Module Installation Sheet (0478-0515-03).

**Figure 4-1 MiS210 Safety Module fitted to an M700**

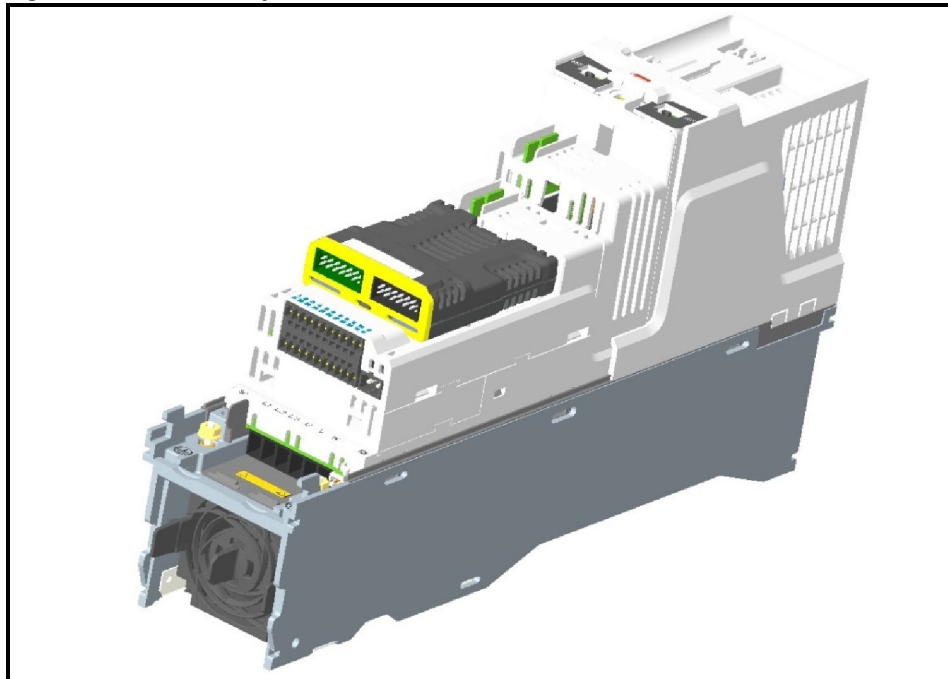

## 4.2.3 MiS250 on M750, M751 and M753

On these drives there are 2 option module slots available, and the MiS250 Safety Module can only be connected in slot 2.

The MiS250 Safety Module checks that the Drive Software is greater than or equal to V01.16.00, as this is the minimum version that allows the drive encoders to be read.

Drive Date Code must be greater than 2134 to be compatible with the MiS250 Safety Module.

#### 4.2.4 Physical connection of MiS250

Place the front of the MiS250 Safety Module under the locating clip on the drive and then push down, refer to MiS210 and MiS250 Safety Module Installation Sheet (0478-0515-03).

Figure 4-2 MiS250 Safety Module Fitted to an M753

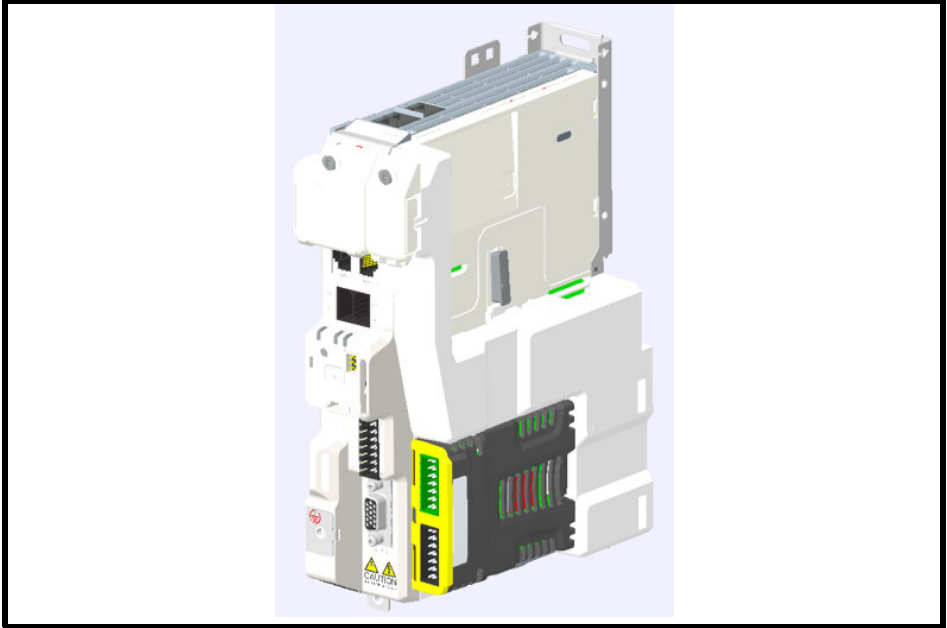

Information
Introduction
Technical Safety Features
<b>Installation</b>
<b>Connect Configuration Tool Introduction</b>
Start Up
Validation
Motion Safety Function Details
Diagnostics and Maintenance
Key Safety Data
Version Control (Amendments)

### 4.3 Connection of Digital IO

The diagram below shows the digital IO connector for the MiS2x0 Safety Module.

Figure 4-3 MiS210 Local Digital IO Connector

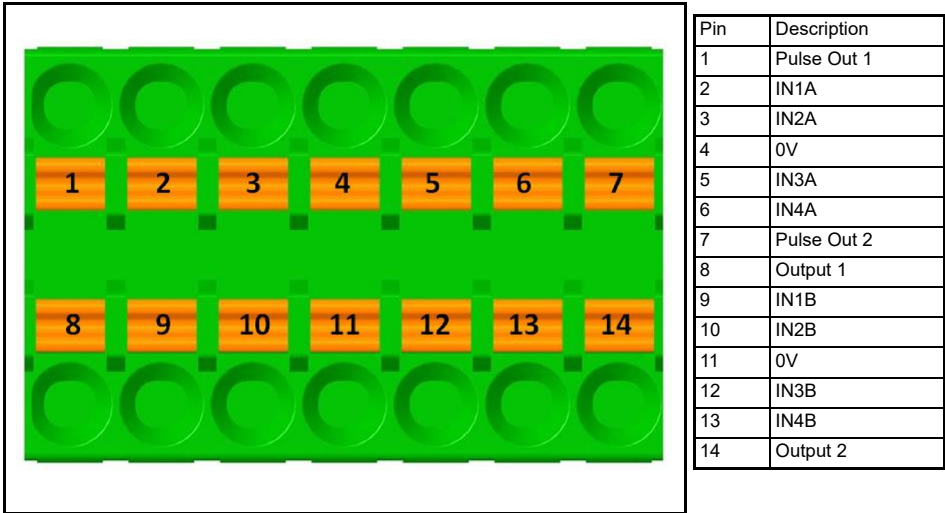

The MiS2x0 Safety Module Inputs and Outputs are classified in IEC 61800-3 2004 +A1:2012 Table 12 as "Ports for process measurement control lines Auxiliary DC Power ports below 60 V" and are configured using Connect. Approved OSSD outputs can be connected without restriction to the inputs. See Section 10 for Key Technical Indicators.

The MiS2x0 Safety Module Inputs and Outputs do not guarantee surge protection therefore where cables exceed 30 m in length the user shall use screened cable with sufficient shielding effectiveness to prevent disturbance of the signals being conveyed or provide external surge protection.

Since the MiS210 Safety Module is controlling the drive STO directly, this means the STO inputs on the drive terminal are floating. Thus, they should be left unconnected. If controlling the STO is not part of the safety system but the user wants to enable the drive, they must configure the MiS210 Safety Module so that the STO output is always active.

For details of the diagnostic coverage of the IO see section 3.1



It may be necessary to protect or segregate the wiring because of a short-circuit from the input cable to a DC supply or a signal of > 5 V, which could cause the input to be enabled. Guidance can be found in ISO 13849-2.

### 4.3.1 Wiring for input pair with no checking

The following diagram shows the wiring for a single pair of Safe Inputs being used without pulse checking.

**Figure 4-4 MiS2x0 single input pair, no pulse checking**

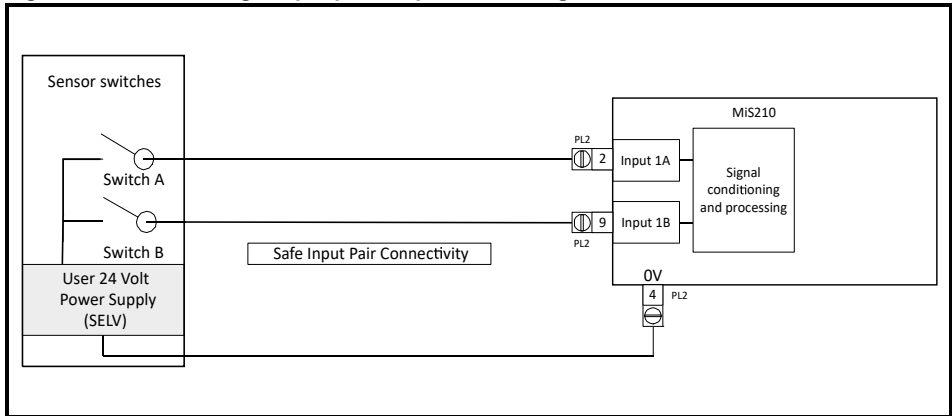

The shield of the cable is not shown, for clarity see section 4.1.

If multiple pairs are required they are wired in the same manner.

### 4.3.2 Wiring for input pair with checking

The following diagram shows the wiring for a single pair of Safe Inputs being used with pulse checking. This should be used for safety-related applications outside of the drive system enclosure. PL e compliance with ISO 13849-1:2006 can be achieved as it is possible to exclude the possibility of a short circuit in the wiring between input and associated pulse output, and of a short circuit between the sensor connections.

**Figure 4-5 MiS2x0 single input Pair, with pulse checking**

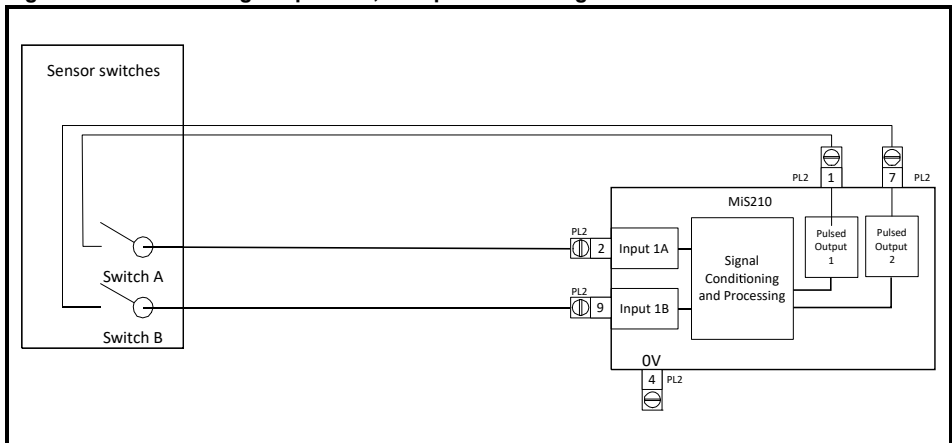

The shield of the cable is not shown, for clarity see section 4.1.

If multiple pairs are required they are wired in the same manner.



The Pulse Outputs should only be connected to the Safe Inputs of the same MiS2x0 Safety Module.

### 4.3.3 Wiring of output

The following diagrams show the wiring for a single Safe Output. The outputs are tested continuously, and an external wiring fault of a short circuit to +24 V can be detected, the MiS2x0 Safety Module will disable its outputs however it cannot provide mitigation for the external fault.

**Figure 4-6 Single output on MiS210**

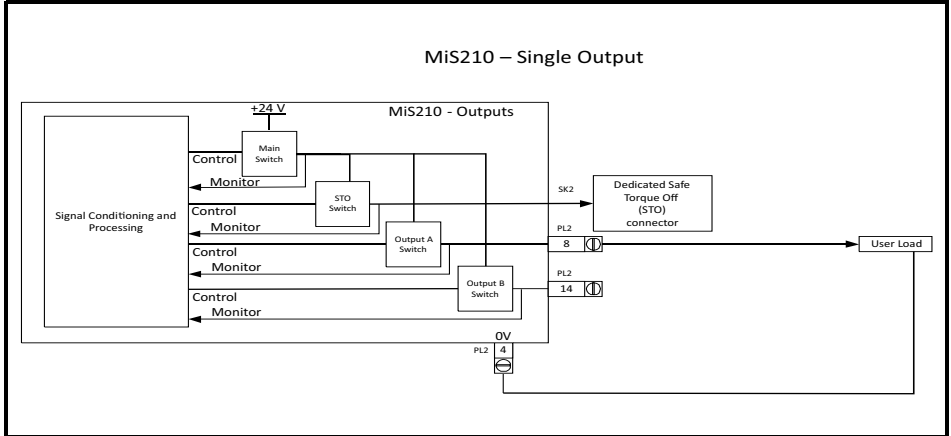

**Figure 4-7 Single output on MiS250**

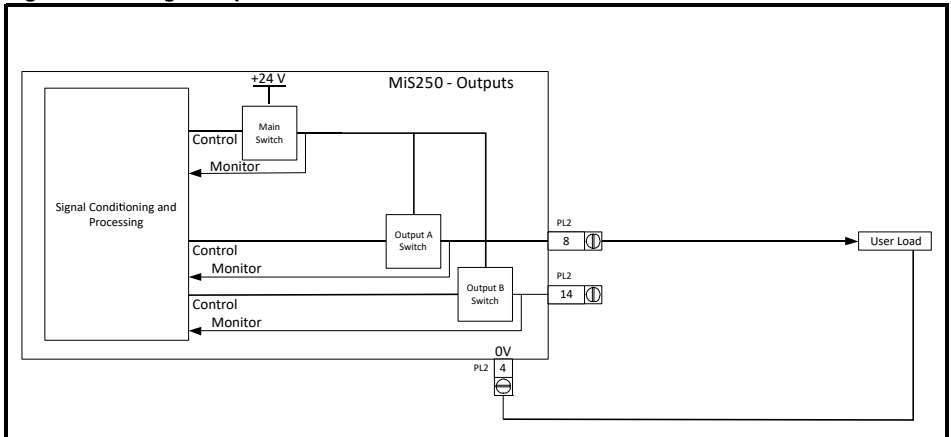

The shield of the cable is not shown, for clarity see section 4.1.

If both outputs are required they are wired in the same manner.

For safety applications for cat 3, PL d in accordance with ISO 13849-1:2006, it is required to engage two complementary outputs as a group, thereby activating for example, two external power contactors.

## 4.4 Connection of encoder(s) and encoder power supplies

The MiS2x0 Safety Module has four possible encoder connections, two on the host drive (A and B) and two on the front panel (1 and 2). Only certain combinations of encoder are possible, and these can be seen in section 3.2



- The AB and Serial encoders connected must comply with the RS-485 Electrical Specification as the MiS2x0 Safety Module uses RS-485 transceiver devices that are powered from the internal 3.3 V supply.
- All encoder cables connected to the MiS2x0 Safety Module should be shielded to protect against EMI.
- Where two encoders are to be used on the same shaft the position reported must have the same sense.

The diagram below shows the encoder connector for the MiS2x0 Safety Module.

**Figure 4-8 MiS2x0 local encoder connection**

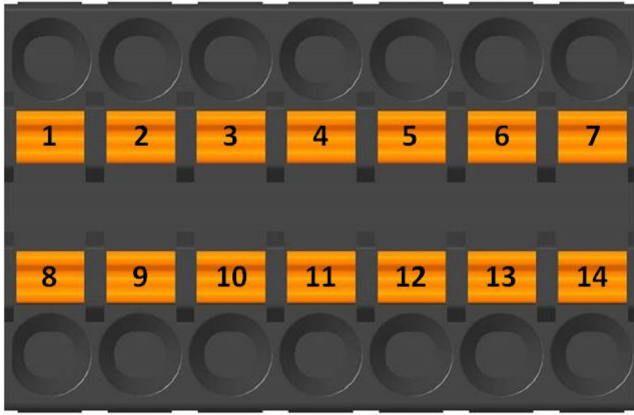

Pin	Description
1	0V
2	Cos1, A1, Data1
3	Sin1, B1, CLK1
4	Cos2, A2, Data2
5	Sin2, B2, CLK2
6	Encoder PSU Output
7	Encoder PSU Input
8	0V
9	Cos1/, A1/, Data1/
10	Sin1/, B1/, CLK1/
11	Cos2/, A2/, Data2/
12	Sin2/, B2/, CLK2/
13	0V
14	0V

### 4.4.1 Power supplies

The MiS2x0 Safety Module can provide a power supply for a single encoder (Enc PSU Out) which can be either 5 V, 8 V or 15 V, see section 8.1. When a secondary encoder is in use the MiS2x0 Safety Module has an additional input on the front panel for monitoring an external power supply (Enc PSU In). This supply can be either 5 V, 8 V or 15 V. The encoder supplies are configured using Connect. The two encoders must be powered by separate power supplies to guard against common cause failures.

**Table 4-1 Encoder power supply values**

Voltage Setting	5 V			8 V			15 V		
	Min	Nom	Max	Min	Nom	Max	Min	Nom	Max
Voltage	4.8 V	5.15 V	5.6 V	7.6 V	8.2 V	8.7 V	13.9 V	15 V	16.1 V
Current (Max)	250 mA			250 mA			200 mA		

The MiS2x0 Safety Module checks the encoder supplies that are in use and uses the following limits.

**Table 4-2 Encoder power supply monitoring limits**

Voltage	Lower Limit	Upper Limit
5 V	4.6 V	5.8 V
8 V	7.14 V	9.3 V
15 V	13.19 V	17.01 V

#### 4.4.2 Wiring

The following diagram shows all possible encoder connections, the exact combination of encoders is dependent upon the application and the SIL required.

The encoder(s) selected for use must be configured in the PC tool, Connect. Refer to section 5.1.2, for details of how to configure the MiS2x0 Safety Module for encoders.

**Figure 4-9 Connection of encoders**

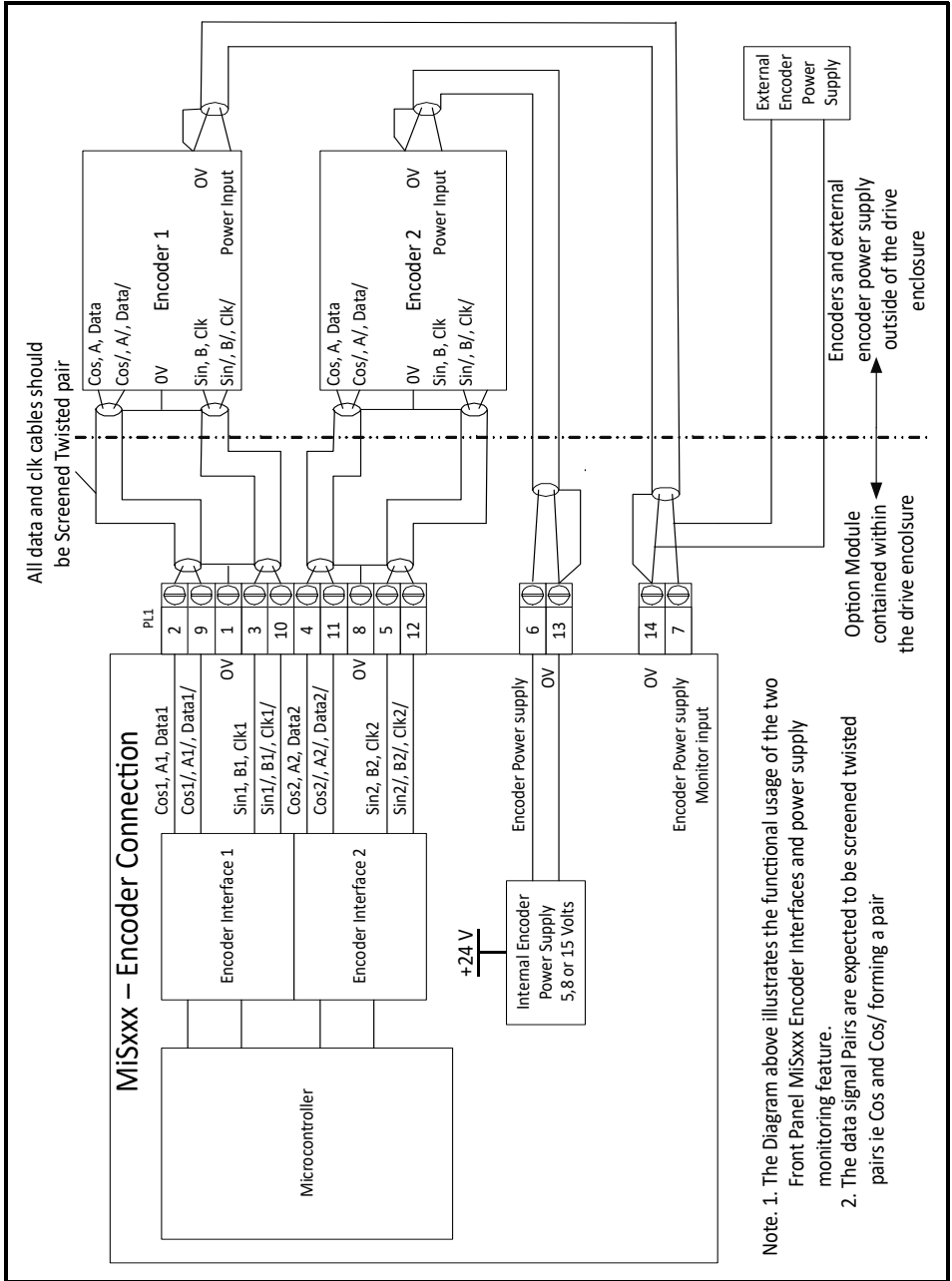

## 4.5 Cables

If an encoder is used on the drive then depending upon the SIL needed by the application it may be necessary to monitor this power supply. The power supply can be monitored by connecting it to the Local Encoder Connector, as detailed in section 4.4.1.

**Figure 4-10 Encoder power supply splitter**

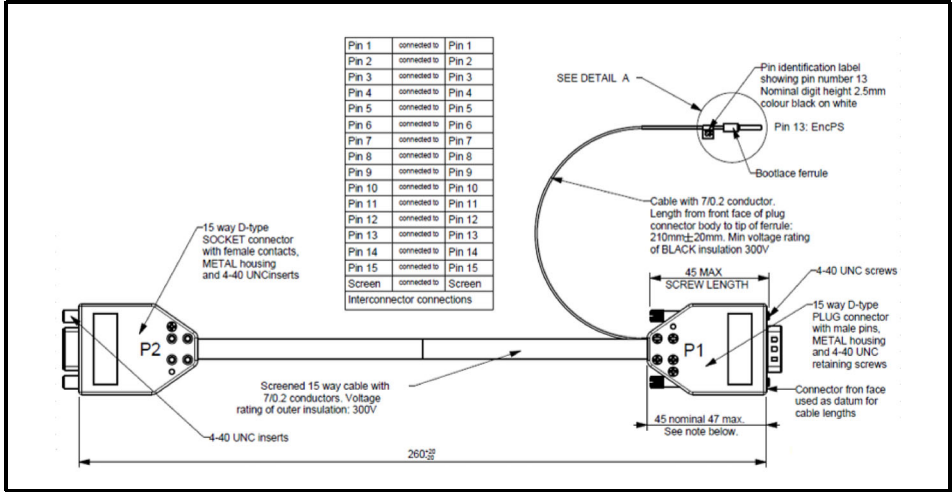

If a SinCos Endat 2.1 encoder or a Hiperface with SinCos encoder is used on the drive, then these types of encoder cannot be snooped by the MiS2x0 Safety Module, however the SinCos signals can be wired to the MiS2x0 Safety Module with a SinCos Splitter Cable and the MiS2x0 Safety Module will see it as a standard SinCos encoder.

**Figure 4-11 Encoder power supply splitter with SinCos**

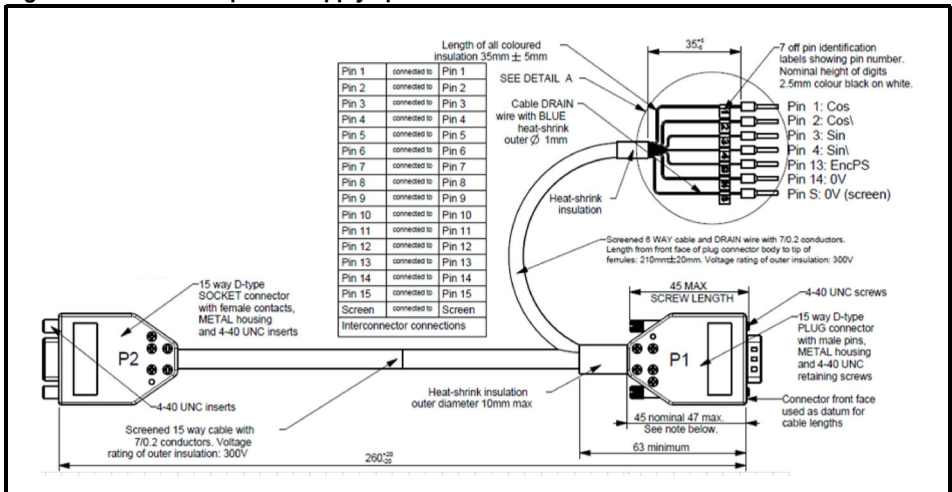

Both types of Splitter Cable can be purchased from Control Techniques Ltd.

**NOTE**

- The MiS2x0 Safety Module does not interpolate the Sin Cos signals so only basic relative position is available.
- The Encoder Power Supply Splitter with SinCos CAN NOT be used to gain a higher SIL rating with a single encoder unless indicated in the Encoder Suppliers Manual.

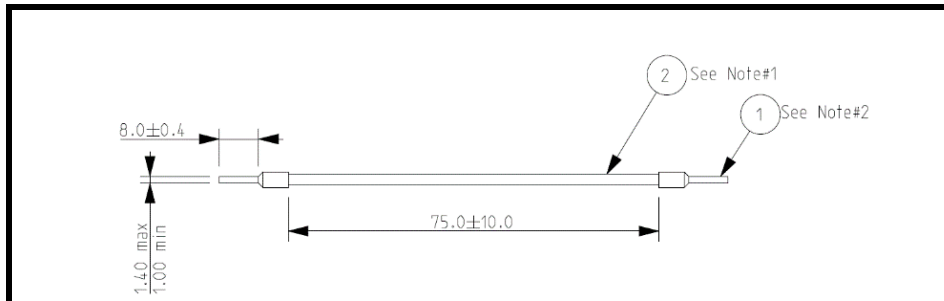
**Figure 4-12 Digitax STO cable**

When using a Digitax Drive with a MiS250 there is no direct connection to the drive STO from the Safety Module, thus a STO Cable is supplied with the MiS250 to allow the user to connect a MiS250 output to the Drive STO terminal.

The user could decide to use either of the two MiS250 safe outputs to drive the STO which means that the cable could be connected to Pin 14 or Pin 8 depending on the user configuration.

On the Digitax drive the STO1 and STO2 are on Pin 2 and Pin 6 respectively. The MiS250 is only required to control one STO to achieve a SIL of 3 as each STO independently achieves SIL3. The user may choose to connect the other STO to another safety device or to 24 V. This is an application specific decision.



- If an external sensor power supply is not routed back through the Local Encoder Connector, any failure of this power supply needs to be incorporated in the fail-safe arrangements for the system as a whole.
- Any PSU powering equipment that is connected to the MiS2x0 Safety Module must be PELV or SELV and referenced to the drive 0 V, to guarantee the voltage does not exceed 60 V under working or fault condition. Failure to observe this could cause a loss of the safety function by damage to the digital output circuit.
- If the Encoder splitter cables are being used the user must ensure that there is a secondary barrier between the user and the cable and its connector hood.

# 5 Connect Configuration Tool Introduction

## 5.1 Connect screen images

When using Connect each page has context sensitive help to guide the user in setting up the function. The context help in Connect is to aid the user, however the information detailed in this Safety Manual is the Master.

### 5.1.1 Network

The following shows the Network Settings screen, the available Safe Networks are CIP Safety and FSoE.

To use CIP Safety the drive (M700, M702, HS70, HS72 or M750) must contain a built in Ethernet module.

To use FSoE the M600, M700, M701, M702, HS70, HS71 or HS72 drives must have a user fit SI-EtherCAT option Module and the M753 drive must have a built in EtherCAT module. This is fully detailed in section 8-7.

#### NOTE

For FSoE those packets sizes that include integers are not compatible with TwinCAT 2 as TwinCAT 2 does not support integers. If Integers are required, please use TwinCAT 3.

Figure 5-1 Connect network screen

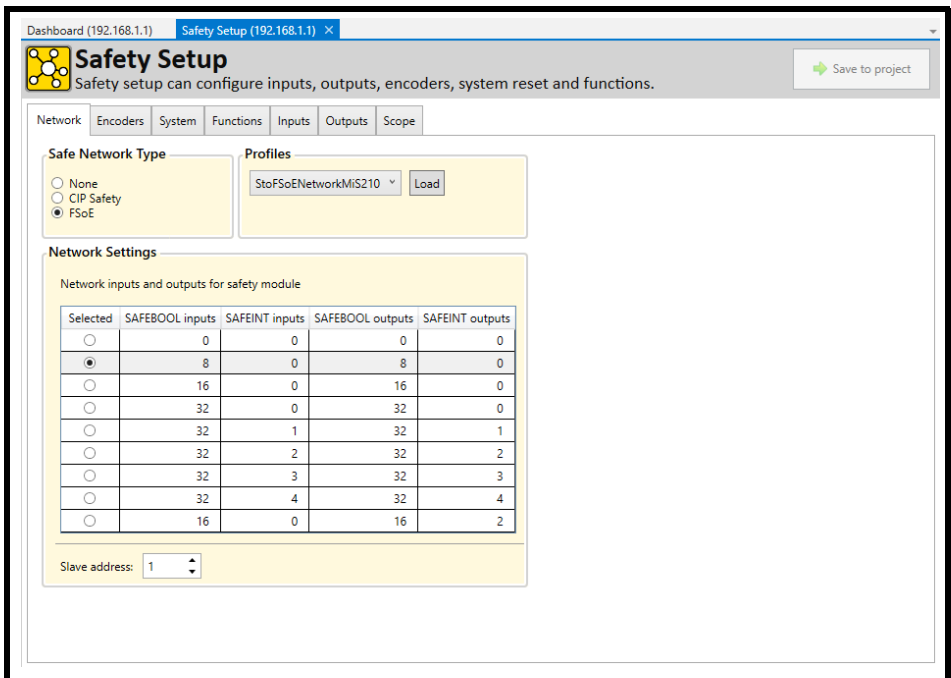

### 5.1.1.1 Network Profiles

Connect provides some Profiles and when selected makes the appropriate connections.

The "StoWiredMiS210" profile connects a Safe Boolean Hardware Input Block to the Safe Torque Off block. The corresponding MiS250 profile uses the Safe Boolean Hardware Outputs (SHOS) block instead of the Safe Torque Off block and the Safe Output 1 on the MiS250 would need to be wired to the Drive STO connection.

For the StoFSoENetworkMiS210 profile Connect selects the network message size to be 0 Integers and 16 Booleans In and 2 Integers and 16 Booleans Out. The corresponding MiS250 profile uses the Safe Boolean Hardware Outputs (SHOS) block instead of the Safe Torque Off block and the Safe Output 1 on the MiS250 would need to be wired to the Drive STO connection.

**Figure 5-2 Connect StoFSoENetworkMiS210 profile**

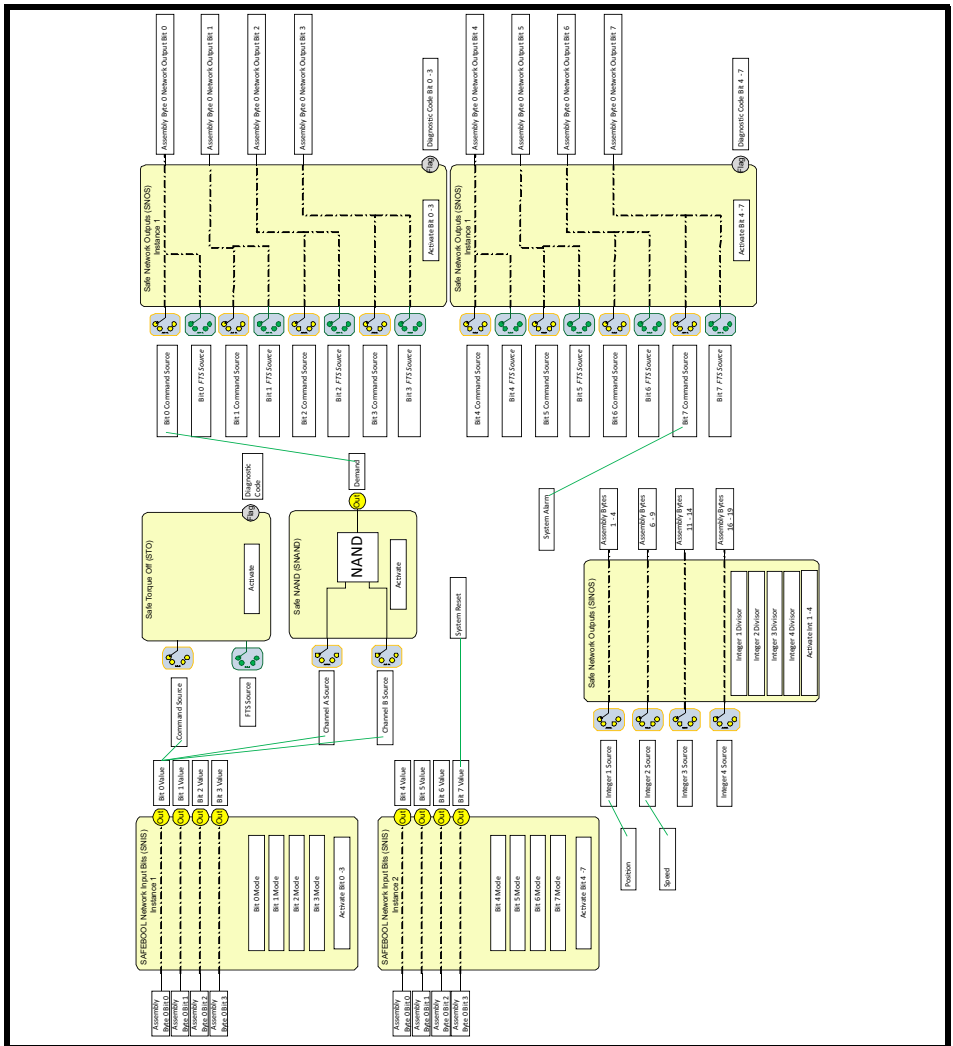

**Figure 5-3 Connect StoWiredMiS210 profile**

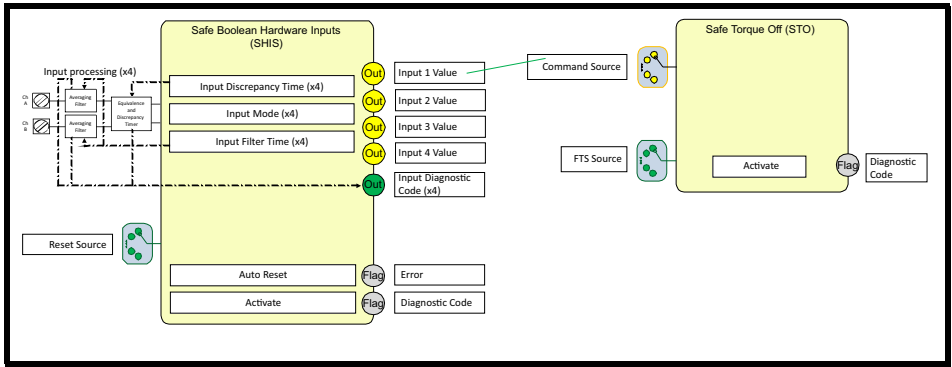

### 5.1.2 Encoders

The following shows the Encoder set up screens, a maximum of 2 encoders can be connected to the MiS2x0 from 4 possible options. The 2 encoders are known as the Primary and Secondary encoders. Once an encoder type is selected the possible options for that type will be shown. This is fully detailed in section 8.1.

**Figure 5-4 Connect encoder screen**

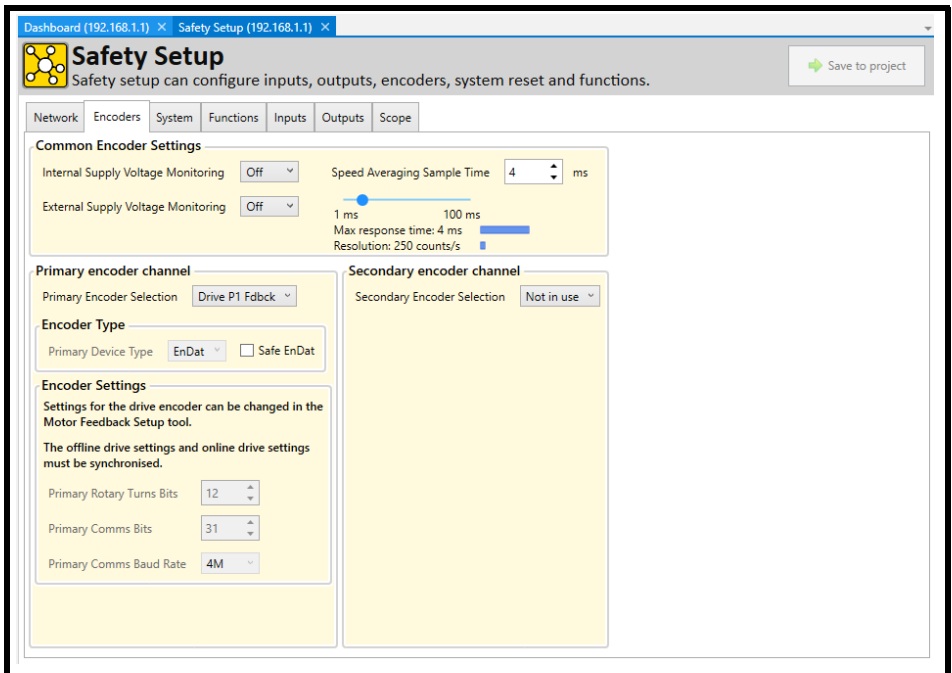

If a drive encoder is being used with the MiS2x0 Safety Module, then the drive encoder parameters must be set up in the drive menu 3 before attempting to set them up in the MiS2x0. If a Configuration is downloaded to the MiS2x0 and the encoder parameters do not match those in the drive, then an encoder error will be reported.

### 5.1.3 System

The following shows the Reset screen, this covers the System Reset to start the MSFs and the Peripheral Fault Reset to acknowledge and clear Peripheral Faults. Both are fully detailed in section 8.1 and section 9.1.

**NOTE**  
The System Start and Auto Reset attributes are not shared with other functionality and if required will need to be explicitly selected. **A risk assessment on the system must take place and justification provided in the system documentation before System Start or Auto Reset feature is used.**

Figure 5-5 Connect reset screen and messages

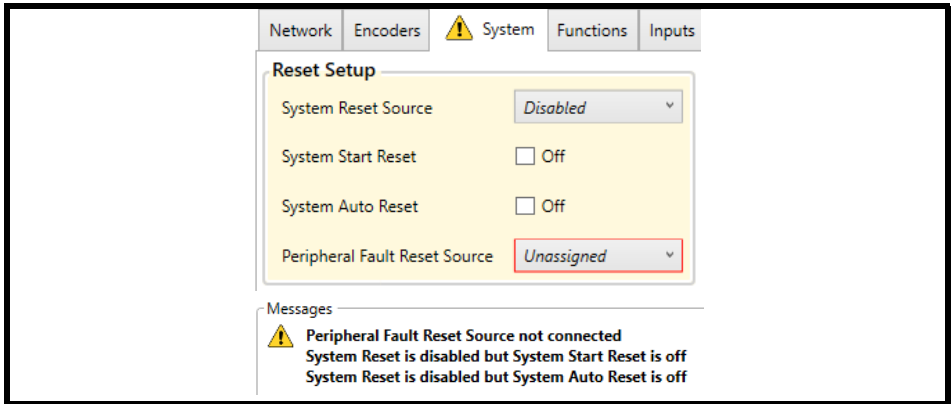

A System Reset is needed to allow the Motion Safety Functions to Start Running when entering Operating Mode and to clear an alarm. There are 3 settings in Connect for System Reset: Reset Source, Start Reset and Auto Reset and they can be set in the following ways.

1. System Reset Source set and both Boxes Unchecked - the user would need a rising edge on the input for a System Reset to occur and the MSFs to start at both start up and to clear an alarm.
2. System Reset Source set and Start Reset Checked and Auto Reset Unchecked - the user would need a rising edge on the input to clear an alarm, but the MSFs would start up automatically on entering Operating Mode.
3. System Reset Source set and Start Reset Unchecked and Auto Reset Checked - the user would need a rising edge on the input to start up the MSFs on entering Operating Mode but it would clear an alarm automatically.
4. System Reset Source set to DISABLED and both Boxes Checked - would automatically reset at start up and to clear an alarm.

The Peripheral Fault Reset Source can either be a separate switch or it can use the System Reset Source, or it can be disabled.

If System Reset Source is as described in 1 above and Peripheral Fault Reset Source is set to System, then the same input source is used to reset peripheral faults as to start and clear alarms.

If System Reset Source is as described in 2 above and Peripheral Fault Reset Source is set to System, then the same input source is used to reset peripheral faults as is used to clear alarms.

If the System Reset Source is as in 3 above and Peripheral Fault Reset Source is set to System, then the same input source is used to reset peripheral faults as is used to start.

If the System Reset is as in 4 above and Peripheral Fault Reset Source is set to System, then this is INVALID.

## 5.1.4 Functions

Each MSF available has its own screen and parameters to set, the one shown below is for STO. To select a MSF you click on its symbol and this opens the options for the selected function. Each of the MSF menus is described in detail in section 8 giving state diagram, settable parameters, and timing diagrams.

Figure 5-6 Connect motion safety function screen

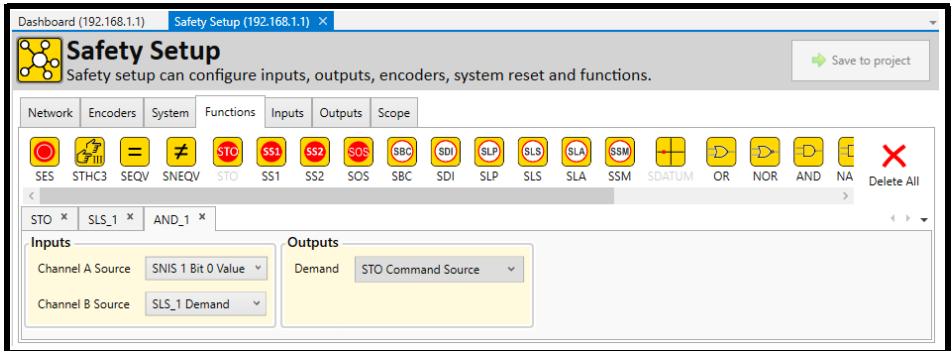

## 5.1.5 Inputs

The following shows the 4 Hardware Inputs which are fully detailed in section 8.25 *Safe Boolean Hardware Inputs, SHIS*, the 16 Non Safe Inputs which are fully detailed in section 8.34 *Non-Safe Boolean Input, BIS* and the Network Inputs which are fully detailed in section 8.28 *Safe Boolean Network Inputs, SNIS* and section 8.30 *Safe Integer Network Inputs, SINIS*

Please note that the Network Input Setup screen depends upon what has been selected in the Network tab.

Figure 5-7 Connect hardware input screen

The screenshot shows the 'Safety Setup' interface for configuring hardware inputs. The main window is titled 'Safe Boolean Hardware Inputs' and is divided into three sections: 'Module I/O Terminal', 'Properties', and 'Connection'.

**Module I/O Terminal:** A vertical green bar represents the terminal with 14 numbered ports. On the left side, ports 8, 9, 10, 11, 12, 13, and 14 are labeled: SHOS Output 1, SHIS Input 1B, SHIS Input 2B, 0V, SHIS Input 3B, SHIS Input 4B, and SHOS Output 2. On the right side, ports 1, 2, 3, 4, 5, 6, and 7 are labeled: Pulsed Output 1, SHIS Input 1A, SHIS Input 2A, 0V, SHIS Input 3A, SHIS Input 4A, and Pulsed Output 2.

**Properties:** A table of configuration parameters for each input:

Input Label	Filter Time (ms)	Discrepancy Time (ms)	Mode
SHIS Input 1A	1,000	6000	ExternalContPS
SHIS Input 2A	1,000	5	Disabled
SHIS Input 3A	1,000	5	Disabled
SHIS Input 4A	1,000	5	Disabled

**Connection:** A dropdown menu for each input, showing the assigned source:

- SHIS Input 1A: SLS\_1 Speed Limit Command Source
- SHIS Input 2A: Unassigned
- SHIS Input 3A: Unassigned
- SHIS Input 4A: Unassigned

**Hardware Input Reset:** A section with a 'Reset Source' dropdown set to 'System' and an 'Auto Reset' checkbox that is currently unchecked.

Figure 5-8 Connect non safe input screen

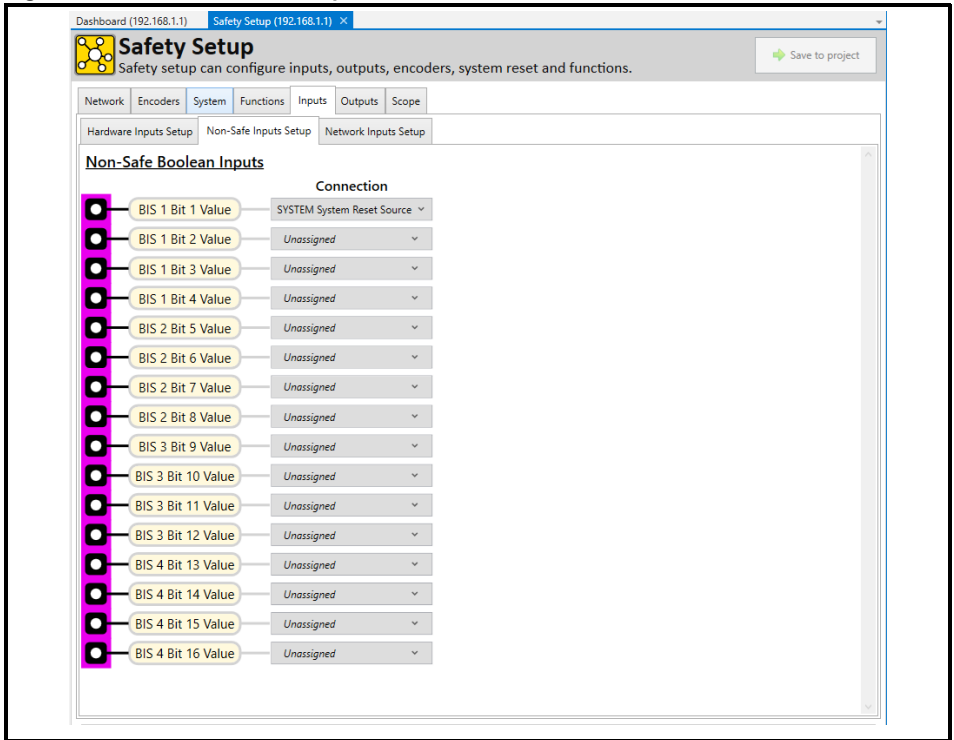
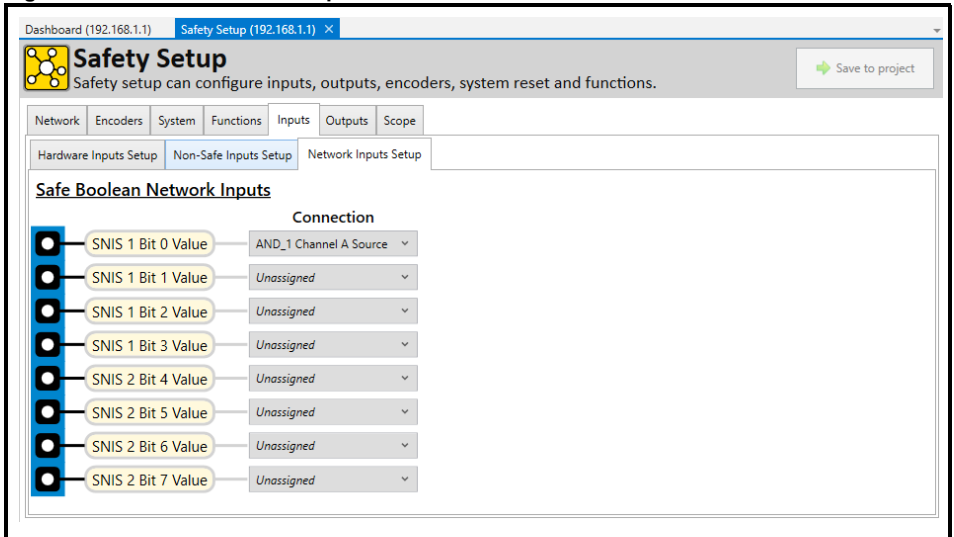

Figure 5-9 Connect network input screen



## 5.1.6 Outputs

The following shows the 2 Hardware Outputs which are fully detailed in section 8.27 *Safe Boolean Hardware Outputs*, SHOS, the 16 Non Safe Outputs which are fully detailed in section 8.35 *Non-Safe Boolean Output*, BOS and the Network outputs which are fully detailed in section 8.29 *Safe Boolean Network Outputs*, SNOS and section 8.31 *Safe Integer Network Outputs*, SINOS.

Please note that the Network Output Setup screen depends upon what has been selected in the Network tab

**Figure 5-10 Connect hardware output screen**

The screenshot displays the 'Safety Setup' application window. The main title is 'Safety Setup' with a subtitle 'Safety setup can configure inputs, outputs, encoders, system reset and functions.' There is a 'Save to project' button in the top right. The interface has several tabs: 'Network', 'Encoders', 'System', 'Functions', 'Inputs', 'Outputs', and 'Scope'. Under the 'Outputs' tab, there are sub-tabs for 'Hardware Outputs Setup', 'Non-Safe Outputs Setup', and 'Network Outputs Setup'. The 'Hardware Outputs Setup' sub-tab is active, showing 'Safe Boolean Hardware Outputs'.

The screen is divided into three main sections:

- Connection:** Two output configurations are shown. Each has a dropdown menu currently set to 'Unassigned'.
- Properties:** For each output, there are three dropdown menus: 'Output 1 FTS Source' (set to 'Disabled'), 'SO1 Status' (set to 'Unassigned'), and 'SO1 Status Inverted' (set to 'Unassigned').
- Module I/O Terminal:** A central vertical terminal strip with 14 numbered terminals (8-14 on the left, 1-7 on the right).
  - Terminal 8 is connected to 'SHOS Output 1'.
  - Terminal 1 is connected to 'Pulsed Output 1'.
  - Terminal 9 is connected to 'SHIS Input 1B'.
  - Terminal 2 is connected to 'SHIS Input 1A'.
  - Terminal 10 is connected to 'SHIS Input 2B'.
  - Terminal 3 is connected to 'SHIS Input 2A'.
  - Terminal 11 is connected to '0V'.
  - Terminal 4 is connected to '0V'.
  - Terminal 12 is connected to 'SHIS Input 3B'.
  - Terminal 5 is connected to 'SHIS Input 3A'.
  - Terminal 13 is connected to 'SHIS Input 4B'.
  - Terminal 6 is connected to 'SHIS Input 4A'.
  - Terminal 14 is connected to 'SHOS Output 2'.
  - Terminal 7 is connected to 'Pulsed Output 2'.

Figure 5-11 Connect non-safe output screen

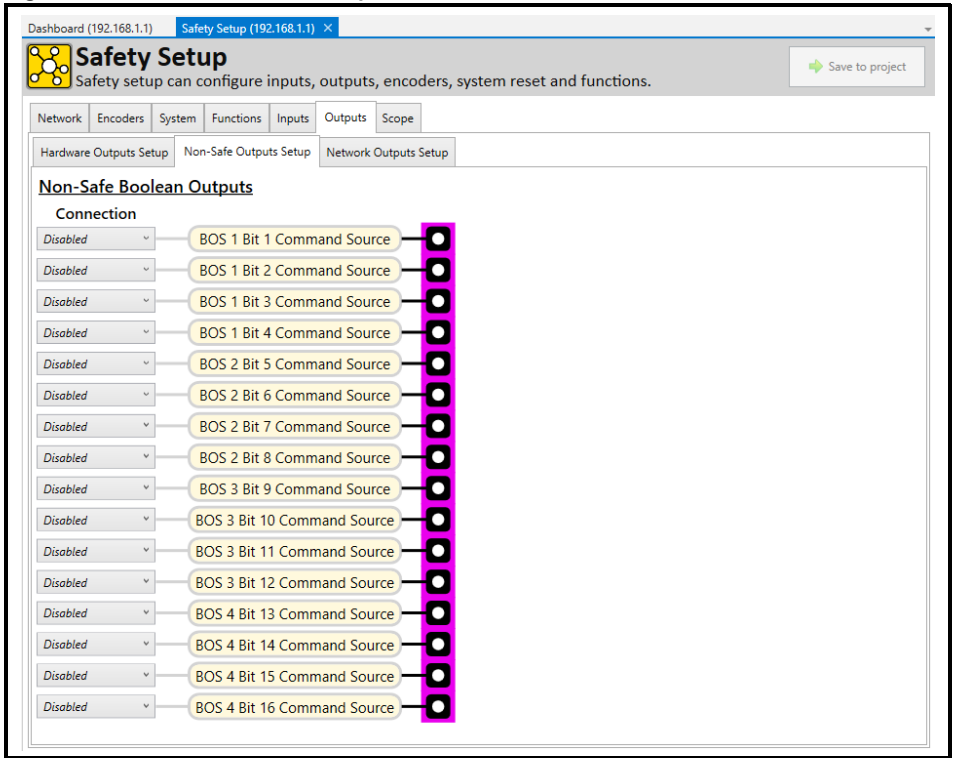
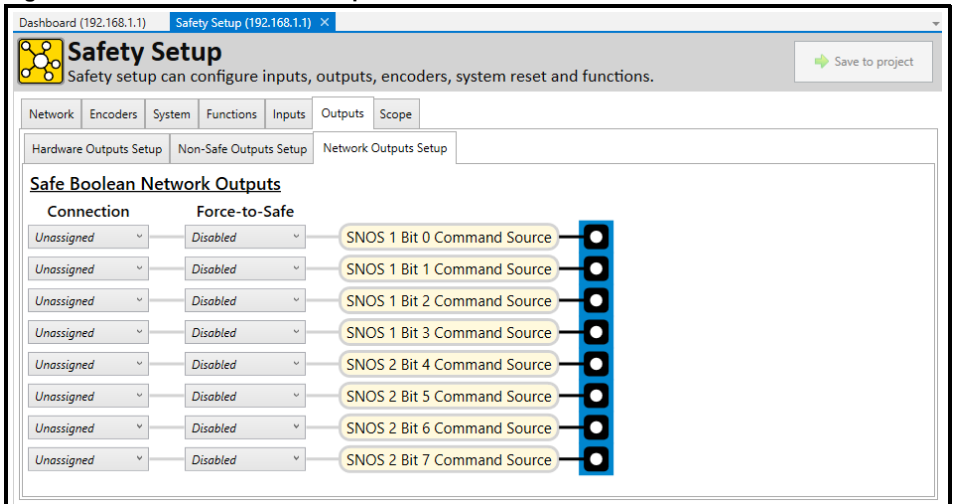

Figure 5-12 Connect network output screen



## 5.1.7 Scope

The following shows the Scope Settings screen, this allows certain outputs from the safety configuration to be mapped to the onboard scope as detailed in section 8.4.

Figure 5-13 Connect scope screen

**Safety Setup** Save to project

Network Encoders System Functions Inputs Outputs **Scope**

Up to four scope channels can be configured by defining the source and divisor for each channel. The Safety module outputs data from the selected scope sources to parameters in the Safety Setup menu. Those parameters can then be monitored using the Scope tool which can be launched from the Safety dashboard.

The scope outputs must not be used as safety critical or safety relevant signals.

Sources	Divisors
Channel 1 Source <input type="text"/>	Channel 1 Divisor <input type="text" value="1"/>
Channel 2 Source <input type="text"/>	Channel 2 Divisor <input type="text" value="1"/>
Channel 3 Source <input type="text"/>	Channel 3 Divisor <input type="text" value="1"/>
Channel 4 Source <input type="text"/>	Channel 4 Divisor <input type="text" value="1"/>

## 5.2 Configuration - Introduction

The MiS2x0 Safety Module is a safety controller designed to be attached to a drive as a plug-in module. MiS2x0 Safety Module is safety network capable and can communicate with a single safety device that is either a CIP Safety originator or a FSoE Master. The illustration below shows how the parts of it fit together.

The following image shows a MiS210, however the same architecture is applicable to the MiS250 except for the direct STO connection from the Safety Module to the Drive.

**Figure 5-14 MiS210 Safety module system**

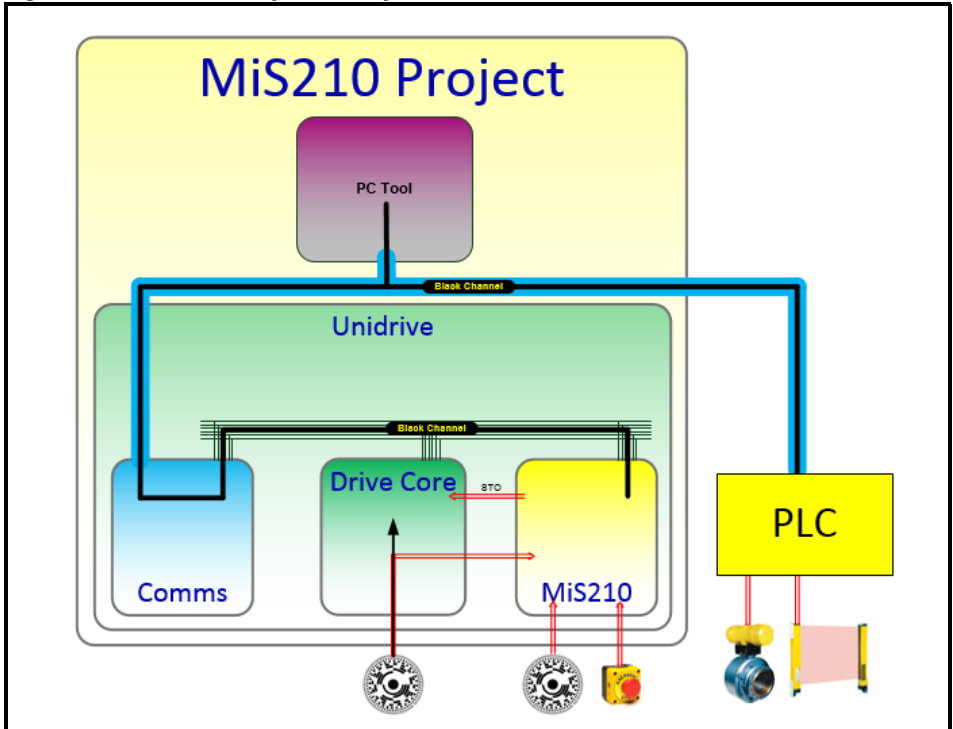

The MiS2x0 Safety Module implements a configurable safety system, all the software functions are pre-existing in the firmware and these functions can be turned on and off using Connect. The functions can then be linked together using source selectors and have functionality determined with attributes.

There are inputs and outputs that cross the boundary of the MiS2x0 Safety Module and there are also inputs and outputs to functions. To clarify this "Hardware Input/Output", "Network Input/Output" and "STO Output" are used for I/O that crosses the MiS2x0 Safety Module boundary and "Function Input/Output" is used to describe the inputs and outputs to and from functions.

### 5.2.1 Connecting and configuring individual function blocks

To allow the user to make interconnections between function blocks all "Function Outputs" have one or more connection points and all "Function Inputs" have an input selector that is used to select where the function input comes from. Function blocks also have attributes that are set at design time in Connect.

**Figure 5-15 Safety Function showing Input Selectors, Attributes and a Connection Point**

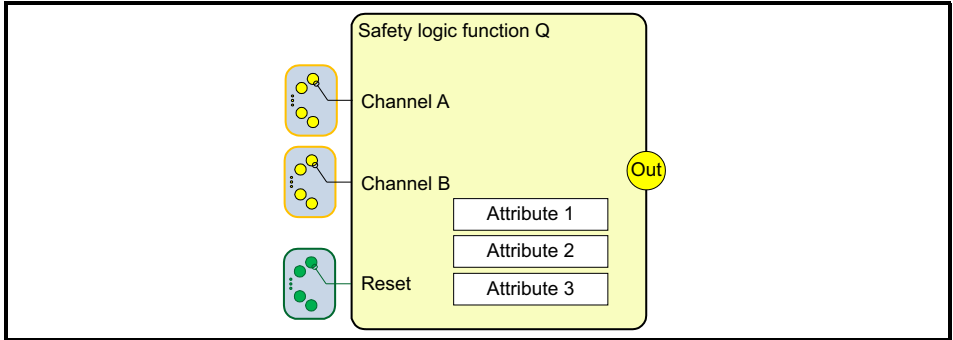

Some functions will have a reset feature, and thus will have an input called Reset and up to 2 attributes called StartReset and AutoReset. These functions will always have at least 1 output which it will hold at safe-state (FALSE) until it is reset. When the function is reset it will evaluate its safety inputs and set its output to TRUE if the safety input state evaluates to operational.

### 5.2.2 Categories of I/O

A Primary Function Input is one that if its function instance is activated it must be connected to a suitable connection point or set to a constant.

A Primary Function Output is one that its function instance is activated it must be selected by a safe input selector.

A Secondary Function Input is the same as a Primary Function Input except that it may be explicitly disabled.

A Secondary Function Output is the same as a Primary Function Output except that it may be explicitly disabled, by a function attribute. If the connection point is disabled it must not be connected.

Tertiary Function Inputs and Outputs are ones which may be left disconnected.

### 5.2.3 Motion safety functions

Motion Safety Functions (MSF) are Function blocks which are designed to Safely monitor the Motion of a single machine axis which will usually be the axis controlled by the drive hosting the MiS2x0 Safety Module. Other utility functions are also provided such as a software emergency stop function and simple Boolean gate functions. MSFs provide the configuration mechanism for MiS2x0.

**Figure 5-16 Diagram showing the 3 function categories**

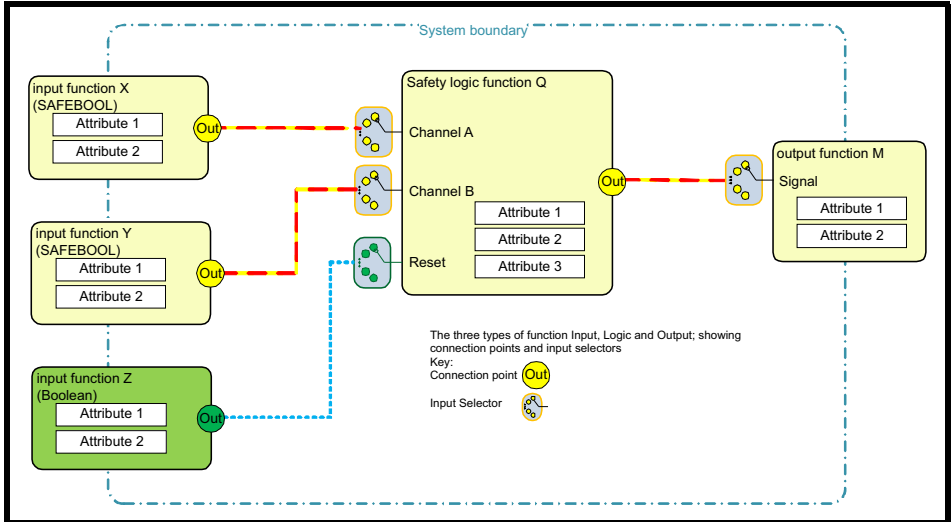

Function Type	Has Input Selector(s)	Has Connection Point(s)	Has Attributes
Input	NO	YES	YES
Logic	YES	YES	YES
Output	YES	NO	YES

All Logic Functions have at least 1 SAFEBOOL connection point (a function output) which must always be connected (via another function's input selector) and must have at least 1 SAFEBOOL input selector which must always be connected to a SAFEBOOL connection point on another function. Logic functions may also have other SAFEBOOL or ordinary Boolean input selectors and connection points, the behavior of these inputs and output varies by function and is described in the function detail sections in section 8.

There can be multiple MSFs of a single type these are called instances; each instance has an activation attribute, if this is FALSE the function is not evaluated, and all its attributes and selectors are set to a default value. Any safe outputs that the function has are set to FALSE. If it is TRUE and it is correctly configured the function is evaluated and the outputs set according to its internal algorithm. In Connect the act of selecting a function sets the activation attribute to TRUE, there is no other way to activate an MSF and they cannot be deactivated at run-time.

## 5.2.4 Diagnostic codes

Some Motion Safety Functions produce diagnostic codes, and these are individually detailed in the sub section for each function, see section 8. Each diagnostic code is 16 bits in length and the top nibble is a bit field with 2 flags and a 2-bit code, the lower 12 bits (11-0) are function dependent.

Bit Number	Value	Description
15	0	Function is Deactivated, (state of bits 14-0 undefined)
	1	Function Activated (state of bits 14-0 undefined)
14	0	No Alarm or Error Detected by this function
	1	Alarm raised and Error Detected by the function
13 & 12	00	Instance operating with single state machine or is in common part of branched state machine, or is in error with alarm raised
	01	Instance operating in branched part of state machine
	10	Multiple state machines in instance with no common part (no errors are generated by function)
	11	MSF is in error, but no alarm raised

Bit15	Bit14	Bit13	Bit12	Hex Value	Description
1	0	0	0	0x8	Activated unbranched state machine
1	0	0	1	0x9	Activated, operating with state machine branched (e.g. function has multiple outputs which may be in different states)
1	0	1	0	0xA	Activated, with multiple independent state machines, no errors are generated by this function
1	0	1	1	0xB	MSF is in error, but no alarm raised
1	1	0	0	0xC	Alarm and Error State (0xD, 0xE, 0xF never occur)

## 5.2.5 Module menu

This is a single menu presented as part of the drive menu system in menu 17 on M600, M700(HS70), M701(HS71), M702(HS72) drives and menu 16 on M750, M751 and M753 drives.

The module menu contains status and diagnostic information for the MiS2x0 Safety Module none of these parameters are safety relevant and are all visible using Connect and the drive keypad.

Menu Name	Description
Module Menu	This menu is always visible using standard communications and via the keypad. It contains diagnostics, non- safe I/O and message transfer. (See section 9.5.3)

## 5.2.6 Safety configuration system data types

The following data types will be supported by the MiS2x0 Safety Module. Ordinary (non-safe) types are a subset of those defined in IEC 61131 part 3.

Type Name	Description
SAFEBOOL	This safe Boolean type is accepted by safety function safe inputs and is produced as the safe output of safety functions. The values from safe Boolean hardware inputs are of this type and safe hardware outputs accept this type. SAFEBOOL value contains the logical state plus integrity and alarm bits. Only the state is output to parameter reads over comms or to non-safe Boolean outputs.
SAFEINT	A custom type for representing 32-bit integers that is subject to additional safety checking. Introduction of the type clarifies the fact that the type is safety specific and of course allows type checking as it does for the SAFEBOOL. For certain functions they will also be configurable inputs (variables) for instances where an adjustable speed (or some other) limit is required.
BOOL	The standard IEC61131-3 Boolean data type, provided for things like function reset, diagnostics and monitoring.
INT, DINT,	16 & 32 bit signed integers as defined in IEC61131-3, these will be used as constant function attributes (non-configurable inputs).
WORD	A bit field with a width of 16 bits used for diagnostic output only.
DWORD	A bit field with a width of 32 bits used for alarm and fault codes.
Selector	A specialized integer type for function input selection, based on a 32-bit unsigned integer. Values < 1000 are used to represent constants and other features: 0 is often the default and has a special meaning: selector not set, this is an illegal value in the consistency test and is used to ensure that the designer makes a decision about the function input. Where this does not apply the minimum value is set to 1 1 means the input is disabled 2 means the input should share the System Reset input (only applies to input selectors for function reset) 3 to 999 RESERVED Values > 999 have a specific format (MM.IPP) where MM is the menu number, I is the instance number and PP is the 'per instance' parameter number

## 6 Start Up

The MiS2x0 Safety Module has 3 modes of operation, IDLE, OPERATING and CONFIGURING and 5 states, STANDBY, EXECUTING, FAILURE and COMMISSIONING (which has 2 sub states TESTING and DOWNLOAD). These are shown in the diagram below. (Testing State is referred to as Test-Comm-On in the Safety State parameter of the Module Menu as additional communications are used to report diagnostics)

The MiS2x0 Safety Module is supplied with no configuration, so when connected and powered up as detailed in section 5, the unit will enter IDLE Mode and STANDBY state.

Only suitably trained safety personnel should perform the configuration of the MiS2x0 Safety Module, which is achieved by logging in using Connect, see section 2.2.

Refer to section 5 *Connect Configuration Tool Introduction*, for details of how to configure the MiS2x0 Safety Module.

**Figure 6-1 Mode and state transitions**

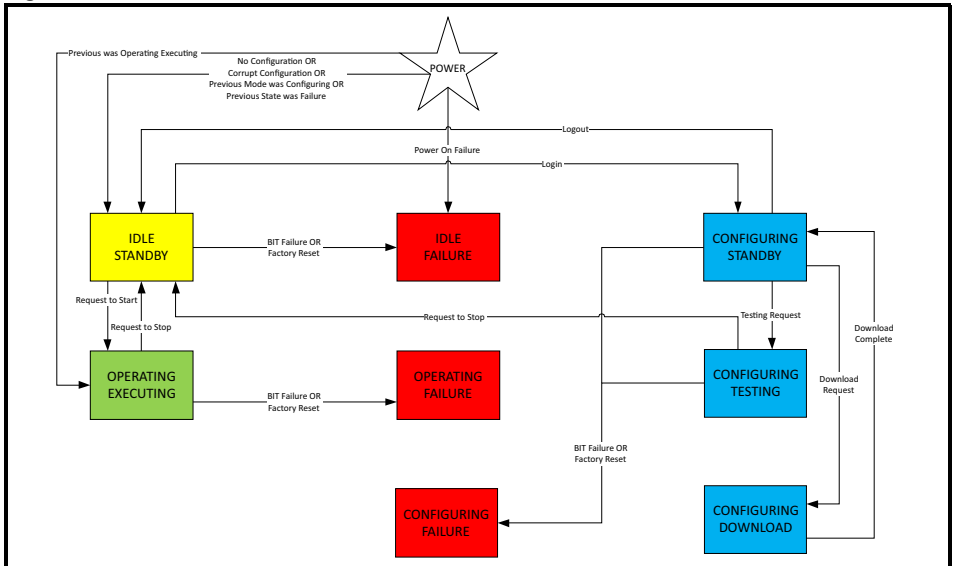

At power on a set of tests is ran on the microcontroller and its peripherals as well as any previously stored configuration. This testing takes a maximum of 150 ms.

All Mode/State transitions that are a request, as shown in the above diagram, are carried out using Connect:

- Request to Start
- Request to Stop
- Factory Reset
- Login
- Logout
- Testing Request
- Download Request

This means that if the unit has a failure and a power cycle has occurred the user will need to use Connect to put the unit into Operating Mode.

There are a number of failures that are deemed to be "Peripheral Faults", if after a power on when the previous mode was Operating/Executing and the last fault was a "Peripheral Fault" and the user configuration is set to allow Peripheral Fault to be Reset then then MiS2x0 will return to Operating/Executing but will wait for a fault acknowledge before running the MSFs. This is the toggling of the switch set to be the Peripheral Fault Reset Source (See section 8.2)

# 7 Validation

## 7.1 Overview

It is the user's responsibility to visually ensure that all configuration data was downloaded correctly. This includes the checking of the signature of the transferred data, and the actual configuration. This is the Validation step of the configuration.

A report is produced by Connect called the Sign-Off report, to assist users in the validation of their safety system. It is a report that details all the configuration of the MiS2x0 Safety Module and it is produced as a PDF. This report will be generated automatically every time the user agrees that the configuration downloaded to the MiS2x0 Safety Module is what they wanted. There is also a Documentation Icon available on the Connect Dashboard at all times, which when selected opens the Documentation Viewer and allows the user to view and/or print the PDF. If multiple versions are available, then all will be shown, and the user can select the one needed.

## 7.2 Format

The report is made up of a number of tables that contain all of the configuration details selected by the user or set by default. The first 2 tables cover the Project Name and the Drive Details, the remaining tables are specific to the configuration selected with a table for each of the functions selected. So there will be tables for the Inputs and Outputs (including network IO) and Encoder Selection as well as each Motion Safety Function and Support Functions.

Each table for a function lists the parameter caption and its type and the value that it is set to. The following screen capture shows an example of the pop-up Download Configuration box with the Safe Emergency Stop function, Safe OR and Safe Torque Off activated.

**Figure 7-1 Download parameter check**

Name	Type	Value (Downloaded)	Value (Uploaded)
NetworkConfig Cip Cons Amt	INT	0 ms	0 ms
NetworkConfig Cip Cons Nte	INT	0 ms	0 ms
SES In	SAFEBOOL	SHIS Input 1	SHIS Input 1
SES Reset	BOOL	Global (BIS Input 1)	Global (BIS Input 1)
SES Start Reset	ENUM	Off	Off
SES Auto Reset	ENUM	Off	Off
SES Activate	BOOL	TRUE	TRUE
OR_1 InA	SAFEBOOL	SES DemandOut	SES DemandOut
OR_1 InB	SAFEBOOL	SHIS Input 1	SHIS Input 1
OR_1 Activate	BOOL	TRUE	TRUE
OR_2 Activate	BOOL	FALSE	FALSE
OR_3 Activate	BOOL	FALSE	FALSE
OR_4 Activate	BOOL	FALSE	FALSE
OR_5 Activate	BOOL	FALSE	FALSE
OR_6 Activate	BOOL	FALSE	FALSE
OR_7 Activate	BOOL	FALSE	FALSE
OR_8 Activate	BOOL	FALSE	FALSE
OR_9 Activate	BOOL	FALSE	FALSE
OR_10 Activate	BOOL	FALSE	FALSE
INOR_1 Activate	BOOL	FALSE	FALSE

Name	Type	Value (Downloaded)	Value (Uploaded)
STO Control	SAFEBOOL	SES DemandOut	SES DemandOut
STO Force To Safe	BOOL	OR_1 Out	OR_1 Out
STO Activate	BOOL	TRUE	TRUE
SHOS Output 1	SAFEBOOL	SES DemandOut	SES DemandOut
SHOS Output 2	SAFEBOOL	Disabled	Disabled
SHOS Activate	BOOL	TRUE	TRUE
SNIS Mode 0	ENUM	Disabled	Disabled
SNIS Mode 1	ENUM	Disabled	Disabled
SNIS Mode 2	ENUM	Disabled	Disabled
SNIS Mode 3	ENUM	Disabled	Disabled
SNIS Activate 0	BOOL	FALSE	FALSE
SNIS Mode 4	ENUM	Disabled	Disabled
SNIS Mode 5	ENUM	Disabled	Disabled
SNIS Mode 6	ENUM	Disabled	Disabled
SNIS Mode 7	ENUM	Disabled	Disabled
SNIS Activate 1	BOOL	FALSE	FALSE
SNIS Activate 2	BOOL	FALSE	FALSE
SNIS Activate 3	BOOL	FALSE	FALSE
SNIS Activate 4	BOOL	FALSE	FALSE
SNIS Activate 5	BOOL	FALSE	FALSE

The following screen shot is of the functions section of the Sign-Off Report produced by Connect.

**Figure 7-2 Sign-Off report sections**

<b>3. Functions</b>		
<i>Safe emergency stop (SES)</i>		
<i>Name</i>	<i>Type</i>	<i>Value</i>
<b>SES In</b>	SAFEBOOL	SHIS Input 1
<b>SES Reset</b>	BOOL	Global (BIS Input 1)
<b>SES Start Reset</b>	ENUM	Off
<b>SES Auto Reset</b>	ENUM	Off
<b>SES Activate</b>	BOOL	TRUE
<i>Safe OR (OR_1)</i>		
<i>Name</i>	<i>Type</i>	<i>Value</i>
<b>OR_1 InA</b>	SAFEBOOL	SES DemandOut
<b>OR_1 InB</b>	SAFEBOOL	SHIS Input 1
<b>OR_1 Activate</b>	BOOL	TRUE
<i>Safe torque off (STO)</i>		
<i>Name</i>	<i>Type</i>	<i>Value</i>
<b>STO Control</b>	SAFEBOOL	SES DemandOut
<b>STO Force To Safe</b>	BOOL	OR_1 Out
<b>STO Activate</b>	BOOL	TRUE

### **7.3 Declaration**

The final section of the Sign Off Report is the Declaration which provides an area for the signature of the Safety Engineer who designed the system and records the username, date and time of the reports generation.

If the user has chosen to use User Units then both the User Units and the Encoder Counts are shown next to each other and it is the user's responsibility to ensure that the conversion is correct.

# 8 Motion Safety Function Details

## 8.1 Encoder setup

This section provides set up and indication for the two encoder inputs that provide the kinematic information to the MiS2x0 Safety Module, these values can be set using Connect in the Screen described in section 5.1.2. There are 2 encoder channels the Primary Channel supplies the kinematic information to any Motion Safety Function (MSF) that needs it, and the Secondary Channel can provide encoder redundancy to increase the system SIL. If two encoders are to be used scaling values are to be set (Encoder Ratio Numerator and Encoder Ratio Denominator) so as encoders with different resolutions can be compared, See section 3.2.7.

Name	Description
Primary Position	Current position in counts, it is fed to any activated MSF that monitors absolute position. (Read Only) It is a 64 bit with the minimum value = -9223372036854775808 and the maximum value = 9223372036854775807
Primary Relative Position per Cycle	Change (in counts) in current position between the start of previous MSF evaluation cycle and the current one, it is fed to any activated MSF that monitors incremental position. The module will treat motion that produces a count of 0 in this parameter as zero speed, however functions that monitor zero speed can be configured to detect creep at zero speed. (Read Only) It is a 64 bit with the minimum value = -9223372036854775808 and the maximum value = 9223372036854775807
Primary Speed	Current speed in counts/s after the speed averaging has been applied, it is fed to any MSF that monitors speed. (Read Only) It is a 64 bit with the minimum value = -9223372036854775808 and the maximum value = 9223372036854775807
Primary Acceleration	Current speed in counts/s after the speed averaging has been applied, it is fed to any MSF that monitors speed. (Read Only) It is a 64 bit with the minimum value = -9223372036854775808 and the maximum value = 9223372036854775807
Primary Acceleration	Acceleration calculated from the Primary Encoder. (Read Only) It is a 64 bit with the minimum value = -9223372036854775808 and the maximum value = 9223372036854775807
Ratio Numerator	Numerator for a scaling calculation that allows the primary and secondary encoders to produce a different count for a given change in position. It is a 32 bit with the minimum value = 1 and the maximum value = 2147483647
Ratio Denominator	Denominator for a scaling calculation that allows the primary and secondary encoders to produce a different count for a given change in position. It is a 32 bit with the minimum value = 1 and the maximum value = 2147483647
Difference Tolerance	Maximum position difference (in counts) that is allowed to build up between the primary and secondary encoders, mechanical lags, oscillations etc. It is a 32 bit with the minimum value = 0 and the maximum value = 4294967295
Speed Averaging Sample Time	Sample time (in ms) for the speed feedback, it smooths out quantisation effects and improves speed resolution at the expense of response time. When set to 1 the speed (counts/s) will change in steps of 1000 counts/s and the system can detect speed changes in 1 ms. When set to 100 the speed will change steps of 10 counts/s but the worst-case response to a change in speed will be 100 ms. For sample times in between these the following formulae can be used: $t_{wcr} = 1000 * t_{ave}$ (worst case response time to change of speed in seconds) $S_{res} = 1000 / t_{ave}$ (the speed resolution in counts/s <sup>-1</sup> ) It is 8 bit with the minimum value = 1 and the maximum value = 100, the default value is 4
Internal Supply Voltage Monitoring	Output voltage and consequent monitoring voltage for the MiS2x0 Safety Module's Encoder PSU Output pin 0: Internal Encoder Supply & Monitoring OFF 1: 5 V Output and Monitoring 2: 8 V Output and Monitoring 3: 15 V Output and Monitoring

Information
Introduction
Technical Safety Features
Installation
Connect Configuration Tool Introduction
Start Up
Validation
<b>Motion Safety Function Details</b>
Diagnostics and Maintenance
Key Safety Data
Version Control (Amendments)

External Supply Voltage Monitoring	Monitoring voltage for an external encoder power supply connected to the MiS2x0 Safety Module's Encoder PSU Input pin 0: External Encoder PSU Monitoring OFF 1: 5 V Monitoring 2: 8 V Monitoring 3: 15 V Monitoring
Maximum Acceleration for Test	Maximum acceleration in counts/s <sup>2</sup> to be used by a diagnostic test for Heidenhain EnDat encoders. It is a 32 bit with the minimum value = 0 and the maximum value = 4294967295
Secondary Position	Current position of the secondary encoder after scaling by the encoder ratio and the offset is applied, for diagnostic purposes. Non-absolute encoders will show the position relative to start up. (Read Only) It is a 64 bit with the minimum value = -9223372036854775808 and the maximum value = 9223372036854775807
Secondary Speed	Current speed of the secondary encoder after scaling by the encoder ratio and the offset is applied, for diagnostic purposes. (Read Only) It is a 64 bit with the minimum value = -9223372036854775808 and the maximum value = 9223372036854775807
Secondary Position Offset	Offset in primary encoder counts that is applied to the secondary encoder position after scaling by the encoder ratio. It is used to detect encoder slip on dual absolute encoder systems. It is a 64 bit with the minimum value = -9223372036854775808 and the maximum value = 9223372036854775807
Primary Encoder Selection	Encoder source for use with the Primary Channel. If MSFs that require kinematic information are in use, then the primary encoder must select an encoder source 0: Not in Use 1: Drive P1 feedback, will snoop encoder connected the drive P1 encoder channel 2: Drive P2 feedback, will snoop encoder connected the drive P2 encoder channel 3: Safety PA feedback, will use encoder connected the MiS2x0 PA encoder channel 4: Safety PB feedback, will use encoder connected the MiS2x0 PB encoder channel
Number of Second Position Bits	Number of bits of the second position within a Safe EnDAT encoder message. (PRIMARY CHANNEL ONLY) It is a 16 bit with the minimum value = 0 and the maximum value = 31
Primary Rotary Turns Bits	Number of rotary turns bits for the encoder. For SinCos and AB encoders this must be set to 25. It is 8 bit with the minimum value = 0 and the maximum value = 25, Default = 16
Primary Comms Bits	Total number of bits of position information in the communications message from the encoder. It is 8 bit with the minimum value = 0 and the maximum value = 48
Primary Comms Baud Rate	Baud rate selection for the encoder, the code numbers are those used in the drive but not all are supported by the safety module 0: 100 k (Direct to MiS2x0) 1: 200 k (Direct to MiS2x0) 2: 300 k (Direct to MiS2x0) 3: 400 k (Direct to MiS2x0) 4: 500 k (Direct to MiS2x0) 5: 1 M (Drive Snoop Only) 6: 1.5 M (Not Used) 7: 2 M (Drive Snoop Only) 8: 4 M (Drive Snoop Only)

Primary Device Type	Encoder type connected to the channel; the code numbers are those used in the drive but not all are supported by the safety module 0: AB (Direct to MiS2x0) 1: FD (Not Supported) 2: FR (Not Supported) 3: AB Servo (A&B channels direct to MiS2x0 only, UVW Channels not used) 4: FD Servo (Not Supported) 5: FR Servo (Not Supported) 6: SC (Direct to MiS2x0) 7: SC Hiperface (Direct to MiS2x0, SC lines only) 8: EnDat (Drive Snoop and Direct to MiS2x0 - EnDat 2.2 Only) 9: SC Endat (Direct to MiS2x0, SC lines only) 10: SSI (Direct to MiS2x0) 11: SC SSI (Direct to MiS2x0, use SC or SSI lines) 12: SC Servo (SC channels direct to MiS2x0 only, UVW Channels not used) 13: BiSS (Not Supported) 14: Resolver (Not Supported) 15: SC SC (Direct to MiS2x0) 16: Commutation Only (Not Supported) 17: Safe EnDat Primary Only (Drive Snoop and Direct to MiS2x0, NOTE: This value has a different meaning to that used on the drive (where 17 means SC BISS)	Information
Primary SSI Binary Mode	Selects SSI Gray or Binary coded signals 0: Gray Coded 1: Binary Coded	Introduction
Secondary Encoder Selection	Encoder source for use with the Secondary Channel. If MSFs that require kinematic information are in use, then the primary encoder must select an encoder source 0: Not in Use 1: Drive P1 feedback, will snoop encoder connected the drive P1 encoder channel 2: Drive P2 feedback, will snoop encoder connected the drive P2 encoder channel 3: Safety PA feedback, will use encoder connected the MiS2x0 PA encoder channel 4: Safety PB feedback, will use encoder connected the MiS2x0 PB encoder channel	Technical Safety Features
Secondary Rotary Turns Bits	Number of rotary turns bits for the encoder. For SinCos and AB encoders this must be set to 25. It is 8 bit with the minimum value = 0 and the maximum value = 25, Default = 16	Installation
Secondary Comms Baud Rate	Baud rate selection for the encoder, the code numbers are those used in the drive but not all are supported by the safety module 0: 100 k (Direct to MiS2x0) 1: 200 k (Direct to MiS2x0) 2: 300 k (Direct to MiS2x0) 3: 400 k (Direct to MiS2x0) 4: 500 k (Direct to MiS2x0) 5: 1 M (Drive Snoop Only) 6: 1.5 M (Not Used) 7: 2 M (Drive Snoop Only) 8: 4 M (Drive Snoop Only)	Connect Configuration Tool Introduction
Start Up	Validation	Motion Safety Function Details
Diagnostics and Maintenance	Key Safety Data	Version Control (Amendments)

Secondary Device Type	Encoder type connected to the channel; the code numbers are those used in the drive but not all are supported by the safety module 0: AB (Direct to MiS2x0) 1: FD (Not Supported) 2: FR (Not Supported) 3: AB Servo (A&B channels direct to MiS2x0 only, UVW Channels not used) 4: FD Servo (Not Supported) 5: FR Servo (Not Supported) 6: SC (Direct to MiS2x0) 7: SC Hiperface (Direct to MiS2x0, SC lines only) 8: EnDat (Drive Snoop and Direct to MiS2x0 - EnDat 2.2 Only) 9: SC Endat (Direct to MiS2x0, SC lines only) 10: SSI (Direct to MiS2x0) 11: SC SSI (Direct to MiS2x0, use SC or SSI lines) 12: SC Servo (SC channels direct to MiS2x0 only, UVW Channels not used) 13: BiSS (Not Supported) 14: Resolver (Not Supported) 15: SC SC (Direct to MiS2x0) 16: Commutation Only (Not Supported) 17: Safe EnDat Primary Only (Drive Snoop and Direct to MiS2x0, NOTE: This value has a different meaning to that used on the drive (where 17 means SC BISS)
Secondary SSI Binary Mode	Selects SSI Gray or Binary coded signals 0: Gray Coded 1: Binary Coded

## 8.2 Module configuration & control

This section provides set up and indication for System Alarms and System Resets, these values can be set using Connect in the Screen described in section 5.1.3.

Name	Description
STO Status	Notification of the STO hardware status for mapping to a Network Output TRUE: No demand for safe torque off FALSE: Safe Torque Off ACTIVATED
Safe Output 1 Status	Notification of the SO1 hardware status for mapping to a Network Output TRUE: No demand for safe state FALSE: Safe State DEMANDED
Safe Output 2 Status	Notification of the SO2 hardware status for mapping to a Network Output TRUE: No demand for safe state FALSE: Safe State DEMANDED
Peripheral Fault Reset Source	Value that will provide the reset source for the peripheral faults, a rising edge on the selected value will cause the MiS2x0 to start executing the motion safety functions again. An Auto Reset is not permitted for this so must use a specific input or have the System Reset Source enabled. 0.000: Default (illegal will cause a configuration error; this must be set by the user) 0.001: Disabled, acts like Phase 1 0.002: Shares the System Reset Source, 2 Rising Edges will be needed, 1st to clear fault and 2nd to start MSFs Numeric ID: From a Non-Safe Boolean Input (BIS) Value of Source Selected Rising Edge (a change from FALSE to TRUE): The system will be reset if the error condition is no longer present Falling edge or unchanging TRUE or FALSE: Does not cause a reset.

System Reset Source	Value that will provide the reset source for system wide alarms and by default will be shared by the resets for each MSF that requires one. A rising edge on the selected value will cause the system state machine to attempt to leave its "Wait for Reset" state providing the cause of the system alarm has cleared. 0.001: Disabled (Start and Auto Reset attributes should both be set to on otherwise it will not be possible to reset the module and it will remain in safe state) Numeric ID: From a Non-Safe Boolean Input (BIS) or Network Input (SNIS) Value of Source Selected Rising Edge (a change from FALSE to TRUE): The system will be reset if the error condition is no longer present Falling edge or unchanging TRUE or FALSE: Does not cause a reset.
Non-Safe Input Values	A read only packed set of the 16 input bits found in the setup menu. Intended for use with scope outputs and host drive scope.
Non-Safe Output Values	A read only packed set of the 16 output bits found in the setup menu. Intended for use with scope outputs and host drive scope.
System Start Reset	Reset behaviour at System Start OFF: No special reset behaviour at start up (a reset signal is required at start up) ON: One-time automatic reset of the function at start up only A risk assessment on the system must take place and justification provided in the system documentation before this feature is used.
System Auto Reset	Reset behaviour after System Start OFF: No special reset behaviour after a start-up (a reset signal is required once the alarm has cleared) ON: No reset is required after the first "start-up" reset (which maybe the automatic start up reset) Note that if this attribute is set, outputs may oscillate between safe and non-safe if a motion safety function is moving in and out of an alarm condition, such as when operating close to a boundary condition. A risk assessment on the system must take place and justification provided in the system documentation before this feature is used.

Information
Introduction
Technical Safety Features
Installation
Connect Configuration Tool Introduction
Start Up
Validation
<b>Motion Safety Function Details</b>
Diagnostics and Maintenance
Key Safety Data
Version Control (Amendments)

## System alarms

Problems with any of the following will raise a system alarm:

- Drive Shared Memory / Brown Out
- Safety Network (if configured for use)
- Encoders (if configured for use)
- Inputs (if configured for use)
- Datum Problems

A System Alarm will be held until the system is reset (either manually or automatically according to the configuration). **When a System Alarm has occurred, the MSFs are not run, and all the safe outputs are set to FALSE until the alarm cause clears, and system is reset.**

## System Reset

Each time the system is restarted a reset (manual or automatic) will be required to move the system state machine into the "Run MSFs" state.

The system reset input may be shared by any individual MSFs reset input (this is done by default). When this is done and functions such as SES are in use it may appear that 2 resets are required to start the system. This is not the case, using SES as an example, the first rising edge moves the system state machine to Run MSFs state. The SES can only be reset once this occurs hence a second edge is required. To avoid this consider using 2 reset inputs (one for the system the other for the SES), or if a risk assessment allows it then the system can be set to automatically reset, and a single reset input can be allocated for the SES.

### NOTE

Automatic system reset cannot be shared with motion safety functions.

**Figure 8-1 Reset state machine**

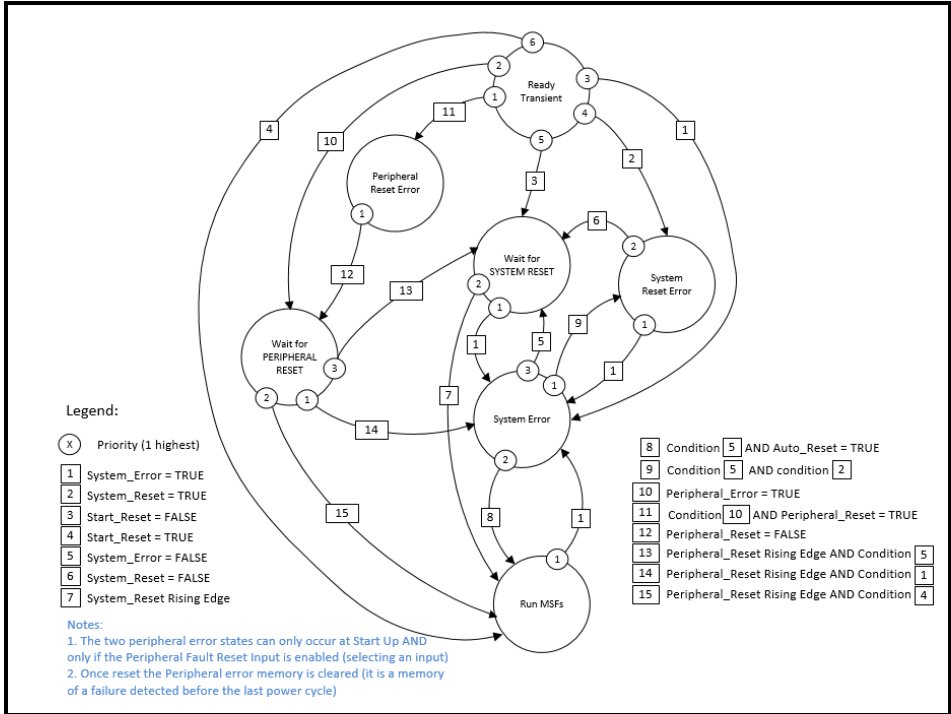

The system reset and alarms is always active, the MSF evaluation and alarms are only active if there are no system alarms. The behaviour of the system reset is described by the state machine diagram.

### 8.3 Safety network configuration

As the PLC may take some time after power up to establish communications, a Network Not Available alarm (0x434) may be raised.

If the Network Cable is removed and replaced, the PLC (if configured to do so) can re-establish a connection. Once this connection has been re-established and a system reset performed on the MiS2x0 Safety Module, the alarm will be cleared. No power cycle is required.

#### 8.3.1 CIPSafety configuration

The MiS2x0 Safety Module will only support CIP Generic Safety or CIP Generic Safety + Standard Profiles for transferring blocks of data in and out of the module using CIPSafety communications.

#### Configuration ownership

On the MiS2x0 Safety Module the configuration is downloaded from Connect and thus it is classed as "Tool Owned". The Configuration Unique Identification (CFUNID) in the MiS2x0 Safety Module is set to all 0xFFs "Tool Owned" so that any attempt to configure it over the network will be rejected. This means that any "Forward Open" messages with configuration data (type 1) received from the PLC will be rejected.

The Originator ID (OUNID) needs to be set up in the PLC to be the same as in the MiS2x0 Safety Module configuration for connection to be established.

The Safety Configuration Identification (SCID) in the PLC must be set manually to match the configuration of the MiS2x0 Safety Module.

The SCID contains the following details:

- Safety Configuration 32bit CRC (SCCRC)
- Safety Configuration Time/Date Stamp (SCTS)

This is composed of a 32-bit (4bytes) signed value in ms, which in the PLC can be set from 0 to 23 h 59 m 59 s 999 ms (0x00000000 - 0x05265BFF) and a 16-bit (2bytes) date stamp, which is the number of days since 1/1/1972.

To ensure the SCID in MiS2x0 Safety Module matches the SCID in the PLC do the following:

- Copy Parameter 006 into the MSW of the SCCRC in the PLC.
- Copy Parameter 007 into the LSW of the SCCRC in the PLC.
- Copy Parameter 016 into the hours/mins/seconds part of the SCTS in the PLC
- Copy Parameter 017 into the milliseconds part of the SCTS in the PLC.
- Copy Parameter 018 into the DD/MM part of the SCTS in the PLC
- Copy Parameter 019 into the YYYY part of the SCTS in the PLC.

When configuring an originator with connection data and the SCID for the target, the connection must be tested and verified. Only then can SCIDs from the target be confirmed.

If you choose to configure safety connections with an SCID=0, you are responsible for ensuring that originators and targets have the correct configurations.

### Target ID (TUNID)

The MiS2x00 Safety Module is a target device and must have a Target Unique Identification (TUNID), which consists of:

- Safety Network Number (SNN) - number in time and date format (2 bytes for date and 4 bytes for time)
- NodeID - IP address of the target device (4 bytes).

The user should assign SNN numbers for each Safety Network or safety sub-net that are unique system wide. To set the SNN the 2 bytes for date are fixed at 0x0004 for EtherNet/IP and the time can be set to any number from 1(0x00000001) to 9999(0x0000270F).

The CIP standard states that computer generated date values between 1/1/2004 (11688) and 5/6/2151 (65534) can be used and values between 1461 and 11687 are Vendor specific. The MiS2x0 Safety Module allows the user to set the 48bit SNN in the configuration setup in Connect. The MS16 bits define the date part and the LS32 bits define the time part.

The NodeID should be assigned and programmed into the specific fieldbus module being used for the Safety Network before a connection is made to the Safety Network.



The Automatic method of setting the SNN should only be used when the safety system is not being relied upon.  
Do not remap the drive option slots as this will cause failures.

## Originator ID (OUNID)

On output devices an OCPUNID must be stored in the Target that matches the OUNID of the PLC to ensure that only one originator can change device outputs. In the MiS2x0 Safety Module this is set to the OUNID defined in the configuration. Two additional windows are used in the Connect configuration to define the originator SNN and NodeID. For the manual setting of the SNN, the user may wish to set the date variable to 0x0001 which defines a backplane originator. If this is the case the NodeID is not an IP address and so the window used to set the NodeID is not defined as an IP address.

## Module reset and alarms

In the MiS2x0 Safety Module a Type 0 reset can be used to reset the CIPSafety communications channel, in the same way that this is done on a power on.

This reset has no impact on the alarm reporting mechanism of the MiS2x0 Safety Module and alarms will need to be dealt with in the usual manner. (see section 9.1.1)

The Type 0 reset is only accepted by the MiS2x0 Safety Module if there is no established IO connection, so the originator must close all connections before the reset is issued.

The Type 0 reset requires a password and for the MiS2x0 Safety Module this is fixed as "Administrator123" (16 characters).

The act of closing the connection will cause an alarm to be raised on the MiS2x0 Safety Module as the network will not be available. This triggers the setting of the Manufacturer Specific alarm flag in the exception status attribute (providing alarms have not been disabled by the PLC). The exception status attribute can be read from the safety module in Rockwell PLC's by using the message block in the PLC ladder logic.

Below is an example of how this can be done:

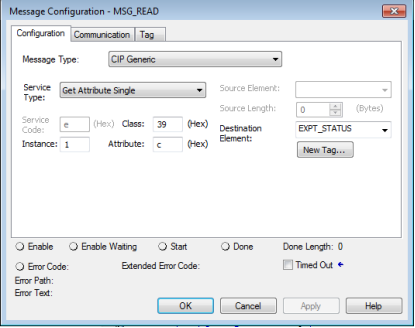
a. Create MSG_READ tag with MESSAGE type in controller tags tab.	
b. Create EXPT_STATUS tag with SINT type, the exception status will be read into this tag.	
c. Switch to the Main Routine window of the Main Task.	
d. Build the rung with the MSG block as shown	
e. Open the MSG block configuration window.	
f. In the Configuration tab, set the message type to 'CIP Generic'. Set service type to 'Get single attribute'. Fill the class, instance and attribute (i.e. Safety exception status is class 0x39, instance 1, attribute 0x0C). Set the destination element to be 'EXPT_STATUS' as defined in a.	

- g. In the Communication tab, set the path to be the MiS2x0 Safety Module. Also tick the 'Connected' box.

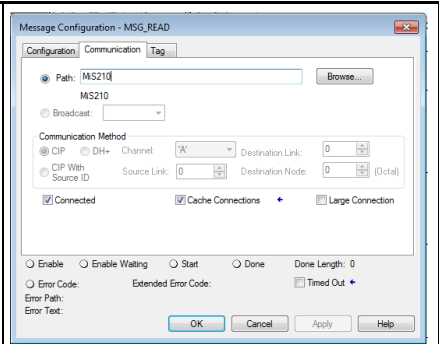

- h. Once the program is downloaded and the PLC set to run, the Monitor Tags tab of the controller tags tab will display the Exception status. The Manufacturer Specific alarm is bit 2 of the exception status.

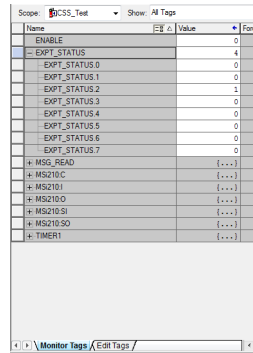

## Input and output assemblies

Safe data can be passed from the PLC to the MiS2x0 Safety Module, from the MiS2x0 Safety Module to the PLC, or in both directions. For each direction an assembly length of up to 20 bytes can be transmitted. Note that an output assembly on the PLC are inputs to the MiS2x0 Safety Module, and an input assembly on the PLC are the outputs of the MiS2x0 Safety Module. The assembly lengths set up in the PLC must exactly match the assembly lengths configured in the device.

The type of data transmitted for the assembly lengths allowed is defined in the Parameter descriptions below. All integers are 32 bit and are passed as Big Endian (MSByte first). The input assembly instance is fixed at 1000 and the output assembly instance is fixed at 1001. The Null instance required by the safety validator is fixed at 199. The screen shot below indicates a typical setup:

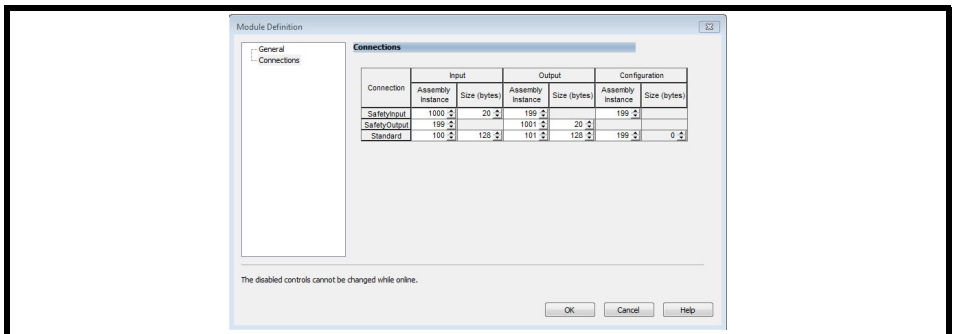

## RPI and timeout multiplier settings

The MiS2x0 Safety Module does not support RPI settings less than 10 ms. Further to this, if an RPI setting of less than 20 ms is required, then the Timeout multiplier must be set to 2 or greater.

### NOTE

If a Network topology does not allow these minimum values to be set, the PLC values must be set to values that can support the topology, or the topology must be changed to support the system requirements.

## Configuration locking

In CIP Safety systems where the configuration is originator owned it is normal for the Lock Attribute to be set in the target once testing and verification is complete. As the MiS2x0 Safety Module network configuration is tool owned, the network configuration is automatically locked on downloading a configuration containing Network setup data. The System testing and verification (section 2.2.4 and section 9) cover the requirements of the CIP Safety Standard.

### 8.3.2 FSoE configuration

#### Safety Drive Profile

The EtherCAT Technology Group (ETG) standard ETG6100 define FSoE communication profiles, allowing for standardisation between device vendors. Connect allows for several predetermined configuration profiles; the "StoFSoENetworkMiS210" and "StoFSoENetworkMiS250" Connect profiles support the ETG6100 Safety Drive Profile over EtherCAT. The ETG allows functionality to be optionally supported by devices and so the following table shows the supported functionality by the "StoFSoENetworkMiS210" and "StoFSoENetworkMiS250" Connect profiles.

Control data from FSoE Master to MiS2x0		
Byte	Bit	Description
0	0	Safe Torque Off 0: activate 1: deactivate
	1.6	Reserved, must be set to 0 by Master logic
	7	Error acknowledge (System Reset) 0: no acknowledgment 1: acknowledge error
1	0..7	Reserved for future use, must be set to 0 by Master

Status data from MiS2x0 to FSoE Master		
Byte	Bit	Description
0	0	Safe Torque Off 0: is not active 1: is active
	1..6	Reserved, must be set to 0 by Master logic
	7	Error 0: no error 1: at least one safety error has occurred
1	0..7	Reserved for future use
2..5	n/a	32 bit Actual Position
6..9	n/a	32 bit Actual Velocity

## Configuration ownership

For the MiS2x0 Safety Module the configuration is downloaded from Connect and thereby owned by Connect. As far as the safety network is concerned the drive (FSoE slave device) is pre-configured with one out of a set of eight different fixed network I/O configurations referenced by a "module ID". In addition to the "module ID", the MiSxx will have been configured (by Connect) with a FSoE "Slave Address". The "Slave address" needs to be unique across all FSoE slave devices in the Safety network. To validate that the Safety network is connected to a drive with the correct MiSxx Safety Module configuration a 64-bit "Signature ID" of the Safety Module configuration is pre-calculated which is automatically validated before the Safety network is allowed to go operational.

## SI-EtherCAT slave setup

By default, the EtherCAT communications module has the black channel disabled. The Black channel is used to exchange FSoE frames between the EtherCAT network and the MiS2x0 and vice-versa. The black channel can be enabled via Pr S.0.47 (where S is the slot the EtherCAT module is fitted in on the drive). To enable the black channel, set Pr S.0.47 to ON and reset the EtherCAT comms module. The value can be saved. The status of the black channel (for diagnostic purposes only) can be viewed via Pr S.1.5 and Pr S.1.6.

When the black channel is enabled, the drive (via the EtherCAT comms module) will make available via the Standard EtherCAT CoE object dictionary; information about the MiS2x0 configuration. These objects can be used by the EtherCAT master or EtherCAT configuration tool to aid in configuration of the Safety network setup. Object 0xF980 contains the "Slave Address". Object 0xF050 contains a list of detected modules. This will be a list of one, the "module ID" which references the MiS2x0 network I/O configuration. Objects 0x1A09 & 0x1609 will have been pre-configured by the slave to contain the FSoE mappings that correspond to the pre-configured network I/O configuration. The mapping objects should not be changed by the EtherCAT master. If they are the drive will refuse to enter the EtherCAT operating state and issue an error.

## EtherCAT network setup

In addition to the standard EtherCAT setup an EtherCAT Master will need to setup the drive (EtherCAT slave) for FSoE. The EtherCAT master will need to enable the FSoE mappings (PDOs 10) by assigning them to sync managers 4 & 5 using the objects 0x1C14 & 0x1C15. This allows exchange of the FSoE frames between the drive and the Safety network.

If using TwinCAT this is normally done automatically via the slots pane like so:

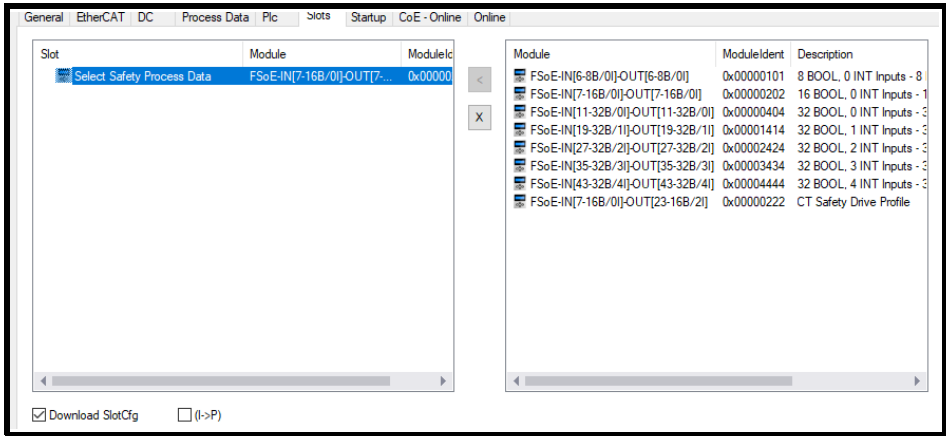

If for some reason this is not automatic, the user will need to copy across the matching configuration from the right pane to the left pane.

### Safety (FSoE) network setup

The FSoE Safety logic device (a.k.a Safety Master) in the Safety network will also need to be configured with values known as the Safety parameters that match the slave configuration. Below are tables of the Objects that need to be configured in the Safety Master for the drive (slave), in the Safety network. These values are exchanged between the Safety Master and the MiS2x0 during the establishment phase of a FSoE connection.

Object	Name	Action required
0xE901:7	Com parameter length	Use default value from ESI file
0xE901:4	Watchdog Time	Default is 100 ms, set according to your requirements
0xE901:8	App parameter Length	Use default value from ESI file
0xE800:1	Safety Signature Word 0	Copy value from Drive parameter 17.009
0xE800:2	Safety Signature Word 1	Copy value from Drive parameter 17.008
0xE800:3	Safety Signature Word 2	Copy value from Drive parameter 17.007
0xE800:4	Safety Signature Word 3	Copy value from Drive parameter 17.006
0xE800:5	Safety Module ID	Use default value from ESI file

If using TwinSAFE this is normally configured via the Safety Parameters and connection panes like so:

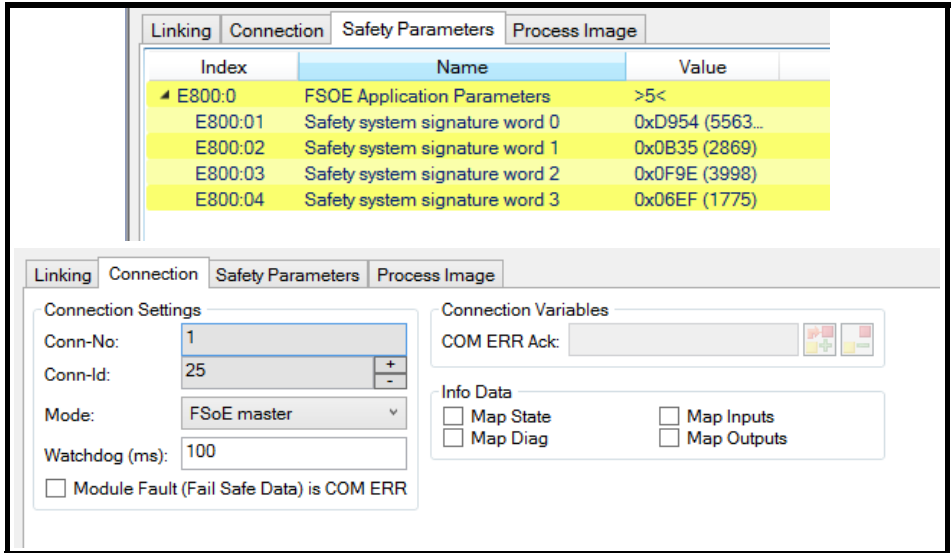

In addition, the FSoE Slave Address needs to be set. In TwinSAFE this is automatically read from the slave:

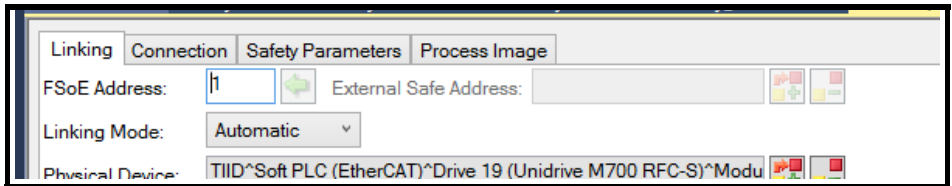

## Terminology

Safe data passed from the Safety Master to the MiS2x0 Safety Module is referred to as outputs by the FSoE configuration tools. That is data going out of the FSoE Safety network. For the MiS2x0 Safety Module configuration tool these are referred to as inputs. That is data coming in from the Safety network.

For the FSoE configuration tool the convention is to start numbering from one, therefore a mapping of 8 booleans are number 1 to 8. For the MiS2x0 configuration tool the same network mapping of 8 booleans are numbered 0 to 7. So FSoE safety network output boolean 1 maps to MiS2x0 connect network input boolean 0 and so on.

### 8.3.3 Network parameters

#### Configuring a No Alarms Present Flag

An alarm not present flag can be constructed by using a SAFEBOOL TRUE constant and connecting it directly to any SNOS output bit. If there is no alarm the corresponding bit received by the PLC will be true, if an alarm occurs the bit will be false. This can then be used by the PLC to take whatever action is required.

Name	Description
Safety Network Slot	Slot on the drive that is to be used to provide the fieldbus interface between the PLC and the MiS2x0 Safety Module. Range 1 – 4
Safety Network	Selection of Safe Network Protocol 0 - No Network 1 - CIP Safety 2 - FSoE
CIP Target SNN	48 Bit SNN for the MiS2x0 Safety Module
CIP Originator SNN	48 Bit SNN for the PLC
CIP Target ID	The MiS2x0 Safety Module Node ID – the IP address required in the Ethernet Module.
CIP Originator ID	The PLC NodeID
FSoE Slave Address	The FSoE Slave Address for the MiS2x0 Safety Module
Byte Length In	This is the length of assembly required to pass data from the PLC to the MiS2x0 Safety Module using CIP Safety 0 – No data transfer required 1 – One byte (8 Booleans) 2 – Five Bytes (8 Booleans and 1 Integer) 3 – Six bytes (16 Booleans and 1 Integer) 4 – Ten Bytes (16 Booleans and 2 Integers) 5 – Eleven Bytes (24 Booleans and 2 Integers) 6 – Fifteen Bytes (24 Booleans and 3 Integers) 7 – Sixteen Bytes (32 Booleans and 3 Integers) 8 – Twenty Bytes (32 Booleans and 4 Integers)
Byte Length Out	This is the length of assembly required to pass data from the MiS2x0 Safety Module to the PLC using CIP Safety 0 - No data transfer required 1 - One byte (8 Booleans) 2 - Five Bytes (8 Booleans and 1 Integer) 3 - Six bytes (16 Booleans and 1 Integer) 4 - Ten Bytes (16 Booleans and 2 Integers) 5 - Eleven Bytes (24 Booleans and 2 Integers) 6 - Fifteen Bytes (24 Booleans and 3 Integers) 7 - Sixteen Bytes (32 Booleans and 3 Integers) 8 - Twenty Bytes (32 Booleans and 4 Integers)
FSoE Module ID	FSoE Module ID as follows 0x0101 = 0 integers and 8 Booleans in each direction 0x0202 = 0 integers and 16 Booleans in each direction 0x0404 = 0 integers and 32 Booleans in each direction 0x1414 = 1 integer and 32 Booleans in each direction 0x2424 = 2 integers and 32 Booleans in each direction 0x3434 = 3 integers and 32 Booleans in each direction 0x4444 = 4 integers and 32 Booleans in each direction 0x0222 = 0 Integers and 16 Boolean In and 2 integers and 16 Booleans Out, Used for Mimic of FSoE Protocol

Information
Introduction
Technical Safety Features
Installation
Connect Configuration Tool Introduction
Start Up
Validation
<b>Motion Safety Function Details</b>
Diagnostics and Maintenance
Key Safety Data
Version Control (Amendments)

## 8.4 Scope Access

Name	Description
Channel 1 Source	Source for 1 <sup>st</sup> scope channel
Channel 2 Source	Source for 2 <sup>nd</sup> scope channel
Channel 3 Source	Source for 3 <sup>rd</sup> scope channel
Channel 4 Source	Source for 4 <sup>th</sup> scope channel
Channel 1 Divisor	A power of 2 divisor for Scope Output 1
Channel 2 Divisor	A power of 2 divisor for Scope Output 2
Channel 3 Divisor	A power of 2 divisor for Scope Output 3
Channel 4 Divisor	A power of 2 divisor for Scope Output 4

## 8.5 Safe Equivalent, SEQV

This function converts two equivalent SAFEBOOL inputs into one SAFEBOOL output. Initially both "Channel A" and "Channel B" inputs need to be FALSE, otherwise an error state will be triggered. Then when both inputs are set TRUE within the Discrepancy Time limit; the function will enter "Operational" and "Demand" output will be set to TRUE. If any of the inputs change state during "Operational", the function will set the output immediately to FALSE and leave "Operational". To enter "Operational" again both inputs need to first be set to FALSE before they can be set to TRUE.

Discrepancy time is the maximum time during which both inputs may have different states, without the function entering an error state. Discrepancy time is counted during the engagement ("Wait for ChA" and "Wait for ChB" states) and during disengagement ("From Active Wait" state). Note that to properly disengage both inputs need to be set to FALSE, Discrepancy Time in "From Active Wait" state is running even when both inputs are set to TRUE.

When Auto Reset is ON there is no need for "Reset" input, the function leaves error states automatically when the error cause is no longer present, and both "Channel A" and "Channel B" inputs are FALSE. "Reset" input needs to be set to constant FALSE when Auto Reset mode is ON. When Auto Reset is OFF the function will leave the error state only when error cause is no longer present, both inputs are FALSE and a rising edge on "Reset" input is detected. Note that "Reset" input is monitored only in error conditions, thus the function will enter "Reset Error" state when a discrepancy time limit was exceeded and the "Reset" input is TRUE, it will not enter "Reset Error" state if the discrepancy time limit was not exceeded.

**Figure 8-2 Diagrammatic representation of the Safe Equivalent function**

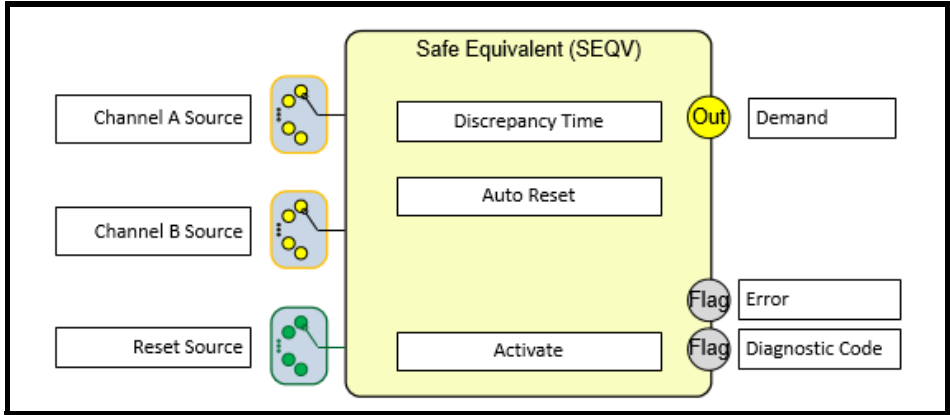

**Standards:**

EN 954-1: 1996

6.2 General safety principles, Idle current

6.2 Error detection for category 3 and 4

**Number of Instances: 8**

Name	Description
Channel A Source	Value that will provide the Channel A input signal. 0.000: Default (Illegal will cause a configuration error, this must be set by the user) Numeric ID: for a valid Output Connector from another block <u>Value of Source Selected</u> TRUE: the meaning of the signal depends on the system. FALSE: the meaning of the signal depends on the system.
Channel B Source	Value that will provide the Channel B input signal. 0.000: Default (Illegal will cause a configuration error, this must be set by the user) Numeric ID: for a valid Output Connector from another block <u>Value of Source Selected</u> TRUE: the meaning of the signal depends on the system. FALSE: the meaning of the signal depends on the system.
Demand	Outputs the safety related response of the function FALSE: Demand for safety related response, request for safe state. TRUE: No demand for safety related response, request for operational state.

Reset Source	Value that will provide the reset source, typically it will be System Reset but may be connected to any input to control the Reset. 0.001: Disabled, the Auto Reset attribute must be set to on. 0.002: Default, indicating that the function reset should share the System Reset input Numeric ID: From a Non-Safe Boolean Input (BIS) or from a SAFEBOOL if it is also connected to another Safe Output. <u>Value of Source Selected</u> Rising Edge (a change from FALSE to TRUE): The function will be reset if the error condition is no longer present Falling edge or unchanging TRUE or FALSE: No effect
Discrepancy Time	The time (in milliseconds) to be used as the discrepancy between Channel A and B
Auto Reset	Reset behaviour after System Start OFF: No special reset behaviour (reset signal is always required to leave the error state) ON: No reset signal is required to exit error state (automatic reset will be applied) A risk assessment on the system must take place and justification provided in the system documentation before this feature is used.
Error	Indicates that the function has detected an error condition TRUE: Error, check Diagnostic Code for details FALSE: No Error
Diagnostic Code	Diagnostic Fault Code, visible in Connect in Test Mode (see separate table)
Activate	This parameter is used to activate the function. Connect will set this value to TRUE when an MSF is selected. TRUE: function will be executed FALSE: function is deactivated.

**Figure 8-3 SEQV State machine**

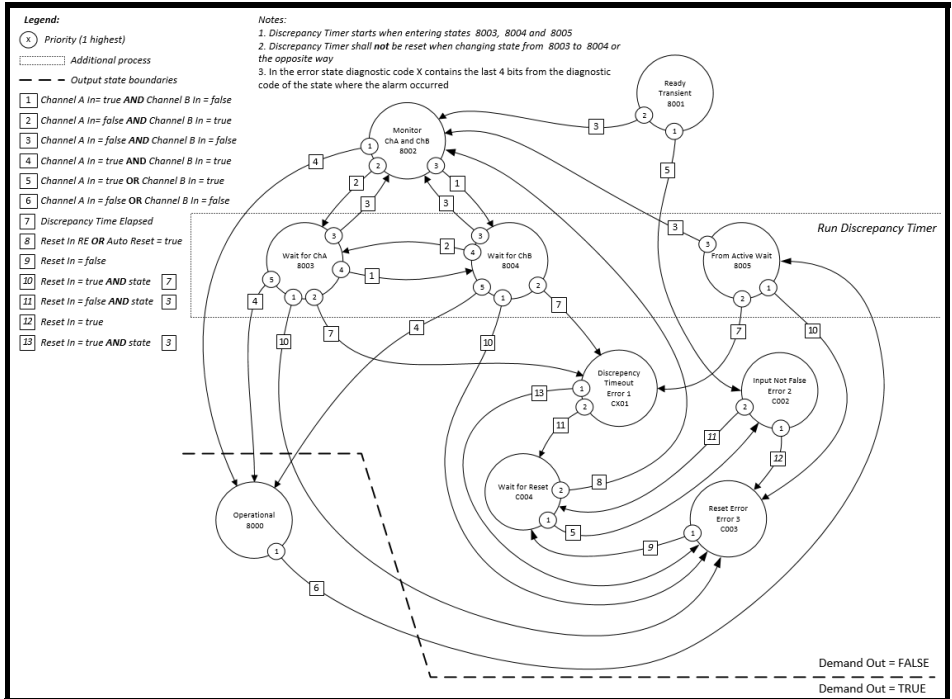
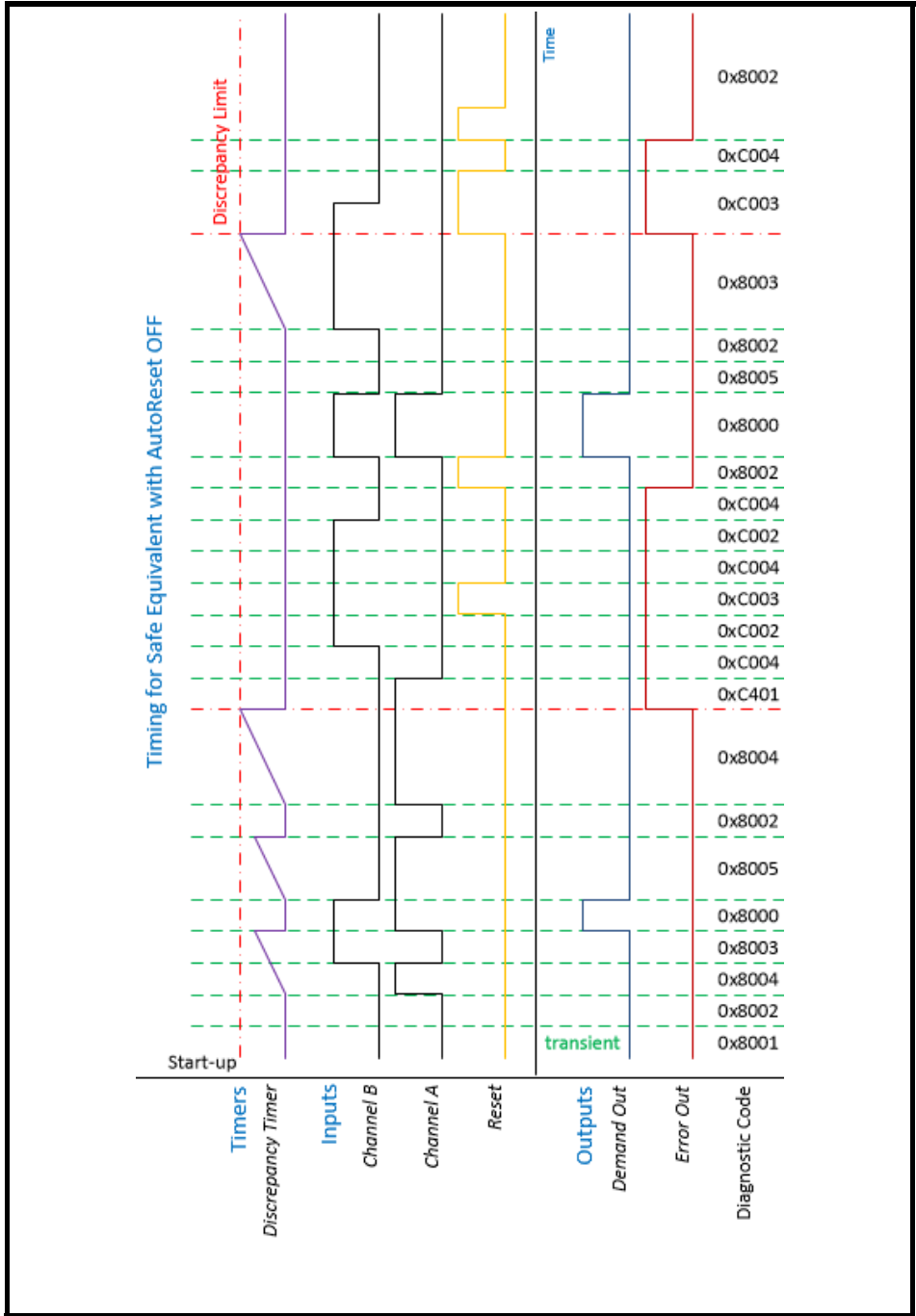
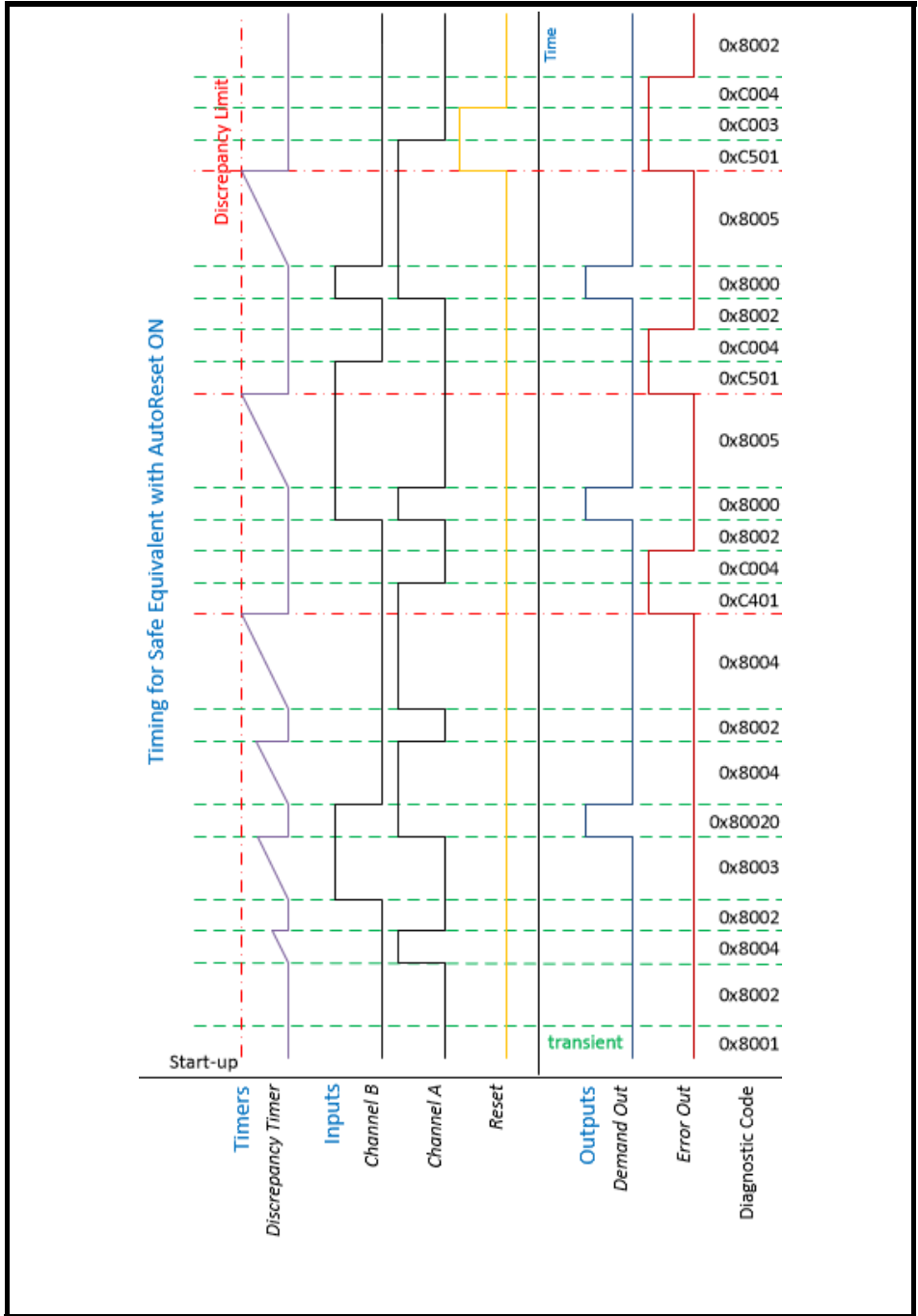

Figure 8-4 SEQV Safe Equivalent timing diagram for auto reset mode turned OFF



Information
Introduction
Technical Safety Features
Installation
Connect Configuration Tool Introduction
Start Up
Validation
<b>Motion Safety Function Details</b>
Diagnostics and Maintenance
Key Safety Data
Version Control (Amendments)

Figure 8-5 SEQV Safe Equivalent timing diagram for auto reset mode turned ON



DIAGNOSTIC ERRORS – Information for the User		
Code	State	Description
0xCx01	Discrepancy Timeout	Discrepancy between Channel A and Channel B exceeded time limit. "x" indicates in which state error occurred. In this state: "Demand" = FALSE, "Error" = TRUE 0xC301 – discrepancy during engagement (Chan A = FALSE, Chan B = TRUE) 0xC401 – discrepancy during engagement (Chan A = TRUE, Chan B = FALSE) 0xC501 – discrepancy during disengagement
0xC002	Input Not False	One or both inputs were TRUE during the function start-up ("Ready" state) or while the function is waiting for reset ("Wait for Reset" state). Both "Channel A" and "Channel B" inputs need to be FALSE to clear this error. In this state: "Demand" = FALSE, "Error" = TRUE
0xC003	Reset Error	"Reset" input was TRUE when discrepancy time limit was exceeded or when "Discrepancy Timeout" error was to be cleared. "Reset" input needs to be FALSE to clear this error. In this state: "Demand" = FALSE, "Error" = TRUE
0xC004	Wait for Reset	Function is ready to be reset after an error. In this state: "Demand" = FALSE, "Error" = TRUE
0x8000	Operational	Both inputs were set to true within discrepancy time limit. "Demand" output is set TRUE, the function remains in this state until one or more inputs go FALSE. In this state: "Demand" = TRUE, "Error" = FALSE
0x8001	Ready	This is a transient state on power up. In this state: "Demand" = FALSE, "Error" = FALSE
0x8002	Monitor ChA and ChB	Both inputs are FALSE, the function monitors "Channel A" and "Channel B" waiting for input. In this state: "Demand" = FALSE, "Error" = FALSE
0x8003	Wait for ChA	"Channel B" input is TRUE, the function waits for the other input to turn TRUE, discrepancy timer is running. In this state: "Demand" = FALSE, "Error" = FALSE
0x8004	Wait for ChB	"Channel A" input is TRUE, the function waits for the other input to turn TRUE, discrepancy timer is running. In this state: "Demand" = FALSE, "Error" = FALSE
0x8005	From Active Wait	Function enter this state after one or more inputs went FALSE while in "Operational" state. Both inputs need to be FALSE to leave this state, discrepancy timer is running. In this state: "Demand" = FALSE, "Error" = FALSE

Information
Introduction
Technical Safety Features
Installation
Connect Configuration Tool Introduction
Start Up
Validation
<b>Motion Safety Function Details</b>
Diagnostics and Maintenance
Key Safety Data
Version Control (Amendments)

## 8.6 Safe Not Equivalent, SNEQV

This function converts two antivalent SAFEBOOL inputs into one SAFEBOOL output. Initially "Channel A" input needs to be set to FALSE and "Channel B" to TRUE at the start-up, otherwise an error state will be triggered. Then when "Channel A" input is set to TRUE and "Channel B" to FALSE (Active Input States) within Discrepancy Time limit the function will enter "Operational" and "Demand" output will be set to TRUE. If any of the inputs change state during "Operational", the function will set the output immediately to FALSE and leave "Operational". To enter "Operational" again inputs need to be set to Default Inputs States ("Channel A" input = FALSE and "Channel B" input = TRUE) before they can be set Active Input State again.

Discrepancy time is the maximum time during which Channel A and Channel B inputs are discrepant without the function entering an error state. Discrepancy time is counted during the engagement ("Wait for ChA" and "Wait for ChB" states) and during disengagement ("From Active Wait" state). Note that to properly disengage Default Inputs state needs to be set, Discrepancy Timer in "From Active Wait" state is running in every input states configuration that is not the Default Inputs State.

When Auto Reset is ON there is no need for "Reset" input, the function leaves error states automatically when the error cause is no longer present, and Default Inputs State is reached. "Reset" input needs to be set to constant FALSE when Auto Reset mode is ON. When Auto Reset is OFF the function will leave the error state only when error cause is no longer present, Default Inputs State is reached and a rising edge on "Reset" input is detected. Note that "Reset" input is monitored only in error conditions, thus the function will enter "Reset Error" state when a discrepancy time limit was exceeded and the "Reset" input is TRUE, it will not enter "Reset Error" state if the discrepancy time limit was not exceeded.

**Figure 8-6 SNEQV Diagrammatic representation of the Safe Not Equivalent function**

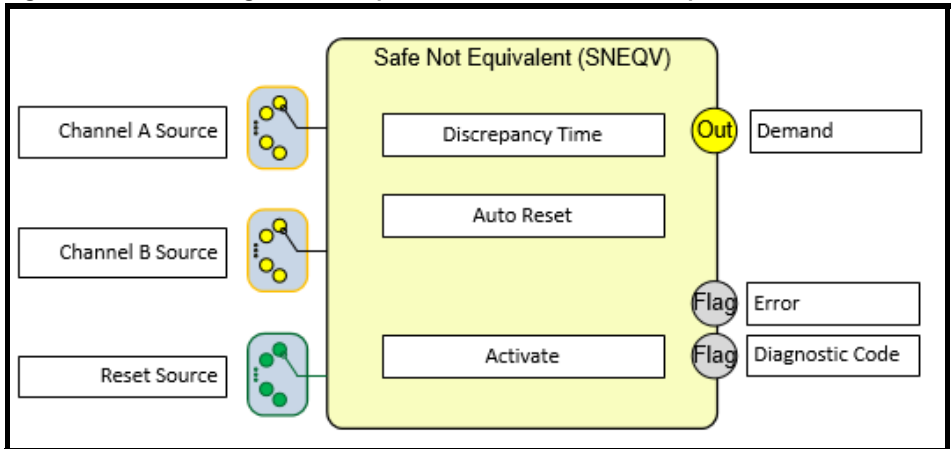

### Standards:

EN 954-1: 1996

6.2 General safety principles, Idle current

6.2 Error detection for category 3 and 4

**Number of Instances: 8**

Name	Description
Channel A Source	Value that will provide the Channel A input signal. 0.000: Default (Illegal will cause a configuration error, this must be set by the user) Numeric ID: for a valid Output Connector from another block <u>Value of Source Selected</u> TRUE: the meaning of the signal depends on the system. FALSE: the meaning of the signal depends on the system.
Channel B Source	Value that will provide the Channel B input signal. 0.000: Default (Illegal will cause a configuration error, this must be set by the user) Numeric ID: for a valid Output Connector from another block <u>Value of Source Selected</u> TRUE: the meaning of the signal depends on the system. FALSE: the meaning of the signal depends on the system.
Demand	Outputs the safety related response of the function FALSE: Demand for safety related response, request for safe state. TRUE: No demand for safety related response, request for operational state.
Reset Source	Value that will provide the reset source, typically it will be System Reset but may be connected to any input to control the Reset. 0.001: Disabled, the Auto Reset attribute must be set to on. 0.002: Default, indicating that the function reset should share the System Reset input Numeric ID: From a Non-Safe Boolean Input (BIS) or from a SAFEBOOL if it is also connected to another Safe Output. <u>Value of Source Selected</u> Rising Edge (a change from FALSE to TRUE): The function will be reset if the error condition is no longer present Falling edge or unchanging TRUE or FALSE: No effect
Discrepancy Time	The time (in milliseconds) to be used as the discrepancy between Channel A and B
Auto Reset	Reset behaviour after System Start OFF: No special reset behaviour (reset signal is always required to leave the error state) ON: No reset signal is required to exit error state (automatic reset will be applied) A risk assessment on the system must take place and justification provided in the system documentation before this feature is used.
Error	Indicates that the function has detected an error condition TRUE: Error, check Diagnostic Out for details FALSE: No Error
Diagnostic Code	Diagnostic Fault Code, visible in Connect in Test Mode (see separate table)
Activate	This parameter is used to activate the function. Connect will set this value to TRUE when an MSF is selected. TRUE: function will be executed FALSE: function is deactivated.

Information
Introduction
Technical Safety Features
Installation
Connect Configuration Tool Introduction
Start Up
Validation
<b>Motion Safety Function Details</b>
Diagnostics and Maintenance
Key Safety Data
Version Control (Amendments)

Figure 8-7 SNEQV State Machine

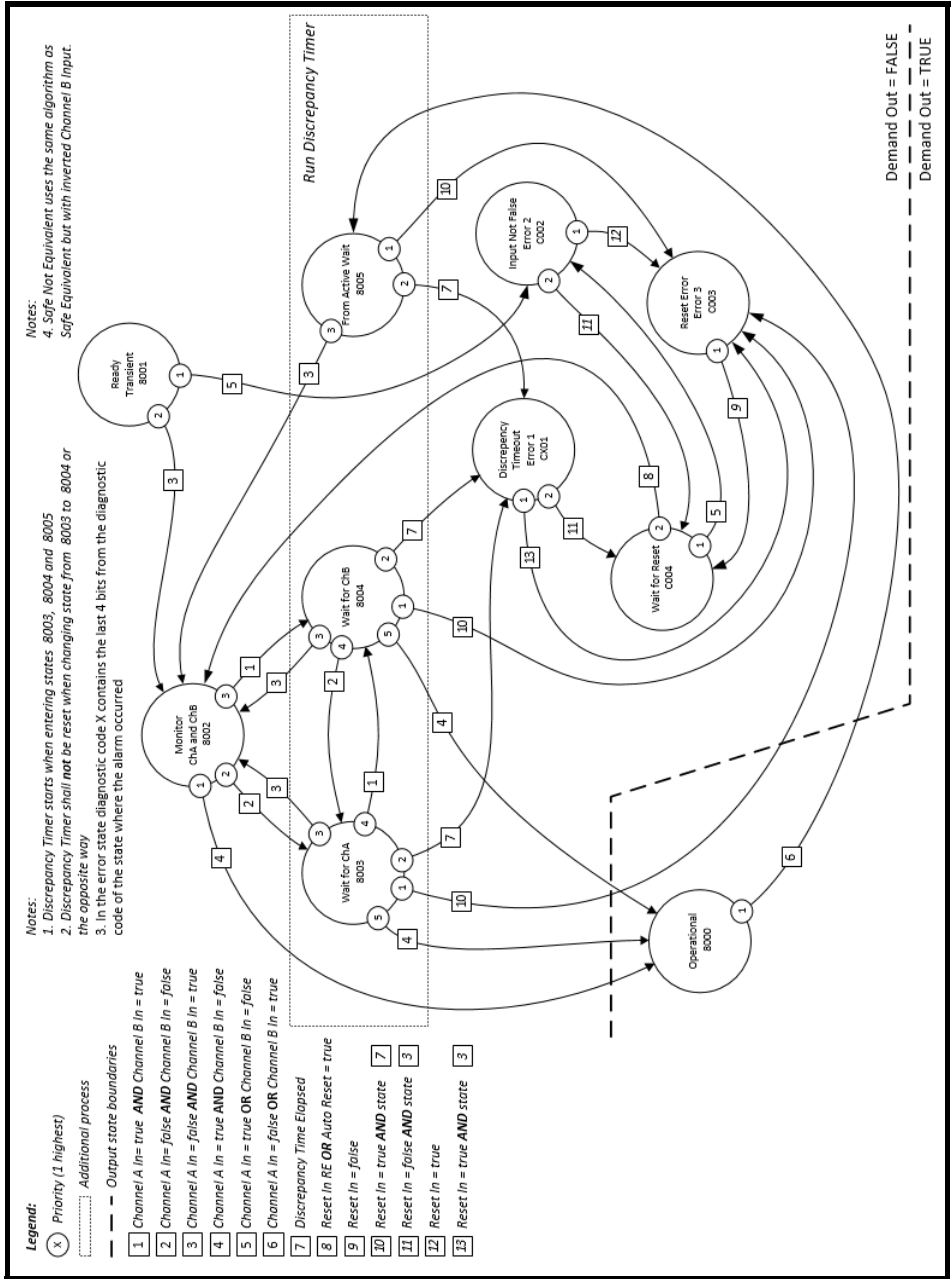
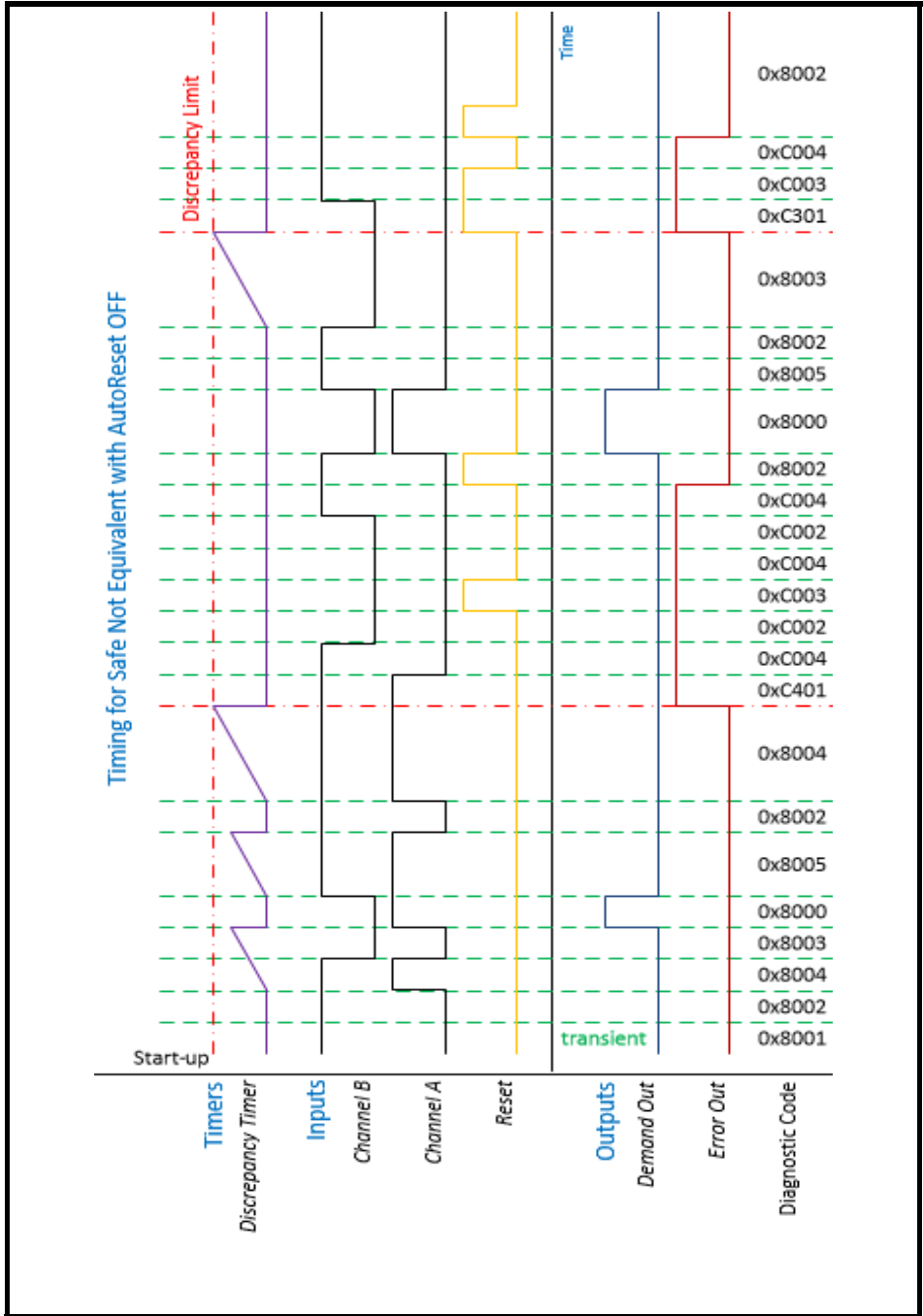
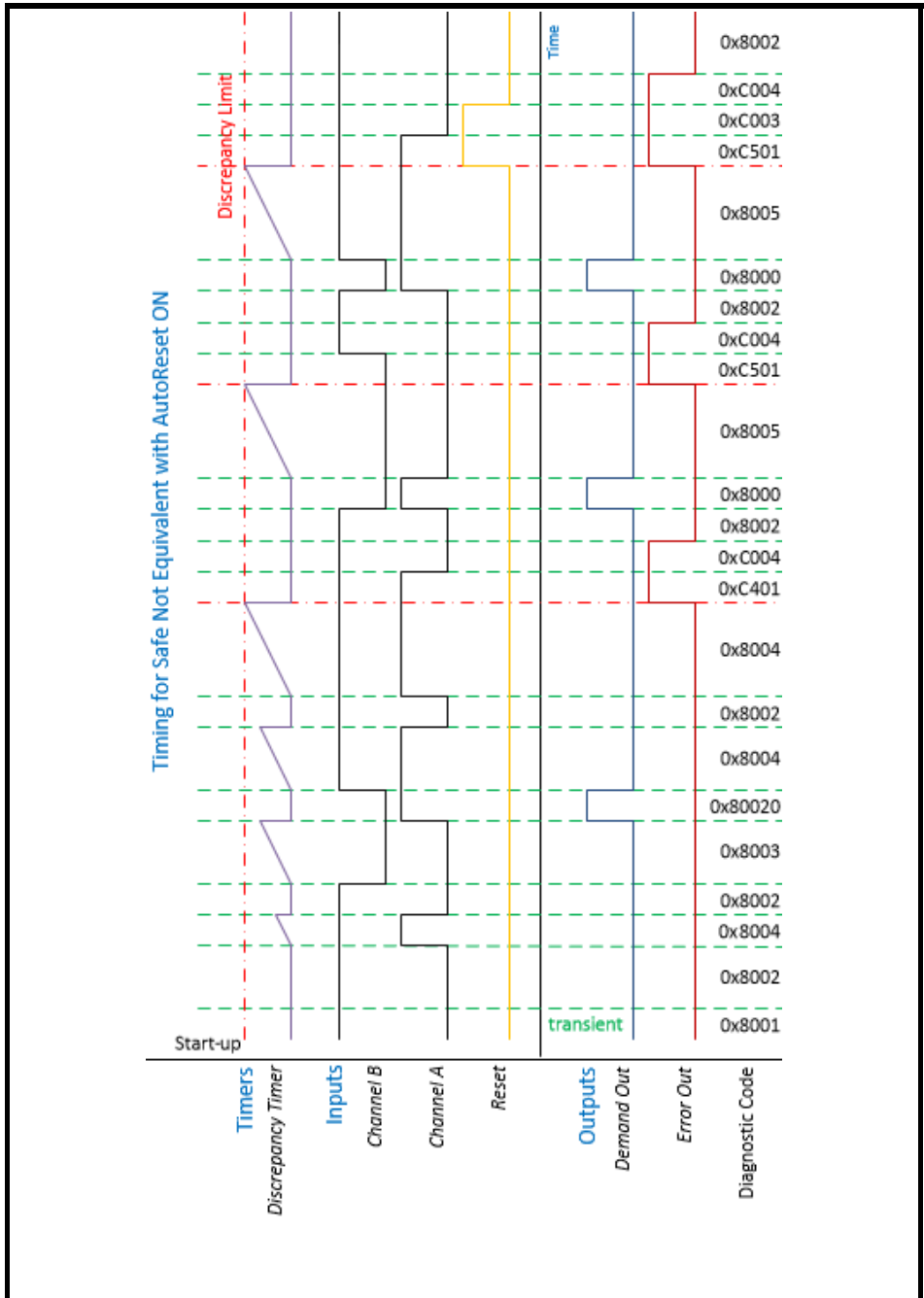

Figure 8-8 SNEQV Safe Not Equivalent timing diagram for auto reset mode turned OFF



Information
Introduction
Technical Safety Features
Installation
Connect Configuration Tool Introduction
Start Up
Validation
<b>Motion Safety Function Details</b>
Diagnoses and Maintenance
Key Safety Data
Version Control (Amendments)

Figure 8-9 SNEQV Safe Not Equivalent timing diagram for auto reset mode turned ON



DIAGNOSTIC ERRORS – Information for the User		
Code	State	Description
0xCx01	Discrepancy Timeout	Discrepancy between Channel A and Channel B exceeded time limit. "X" indicates in which state error occurred. In this state: "Demand" = FALSE, "Error" = TRUE 0xC301 - discrepancy during engagement (Chan A = FALSE, Chan B = FALSE) 0xC401 - discrepancy during engagement (Chan A = TRUE, Chan B = TRUE) 0xC501 - discrepancy during disengagement
0xC002	Input Not False	"Channel A" was TRUE or/and "Channel B" was FALSE during the function start-up ("Ready" state) or while the function is waiting for reset ("Wait for Reset" state). "Channel A" needs to be FALSE and "Channel B" needs to be TRUE to clear this error. In this state: "Demand" = FALSE, "Error" = TRUE
0xC003	Reset Error	"Reset" input was TRUE when discrepancy time limit was exceeded or when "Discrepancy Timeout" error was to be cleared. "Reset" input needs to be FALSE to clear this error. In this state: "Demand" = FALSE, "Error" = TRUE
0xC004	Wait for Reset	Function is ready to be reset after an error. In this state: "Demand" = FALSE, "Error" = TRUE
0x8000	Operational	"Channel A" was set to TRUE and "Channel B" to FALSE within discrepancy time limit. "Demand" output is set TRUE, the function remains in this state until one or more inputs change state. In this state: "Demand" = TRUE, "Error" = FALSE
0x8001	Ready	This is a transient state on power up. In this state: "Demand" = FALSE, "Error" = FALSE
0x8002	Monitor ChA and ChB	"Channel A" input is FALSE and "Channel B" input is TRUE, the function monitors "Channel A" and "Channel B" waiting for input. In this state: "Demand" = FALSE, "Error" = FALSE
0x8003	Wait for ChA	"Channel B" input is FALSE, the function waits for the other input to turn TRUE, discrepancy timer is running. In this state: "Demand" = FALSE, "Error" = FALSE
0x8004	Wait for ChB	"Channel A" input is TRUE, the function waits for the other input to turn FALSE, discrepancy timer is running. In this state: "Demand" = FALSE, "Error" = FALSE
0x8005	From Active Wait	Function enter this state after "Channel A" is set FALSE or "Channel B" is set TRUE while the function is in "Operational" state. "Channel A" needs to be FALSE and "Channel B" needs to be TRUE to leave this state, discrepancy timer is running. In this state: "Demand" = FALSE, "Error" = FALSE

Information
Introduction
Technical Safety Features
Installation
Connect Configuration Tool Introduction
Start Up
Validation
Motion Safety Function Details
Diagnostics and Maintenance
Key Safety Data
Version Control (Amendments)

## 8.7 Safe Emergency Stop, SES

This function tests its single safe input for its state, provides reset functionality and sets the output accordingly. It supports a full manual reset and can be used without other safety logic functions where the MiS2x0 Safety Module is acting as safety controller. With the STO function it provides the functionality to support an emergency switch off (Emergency Stop Category 0). With other functions it can provide functionality for Emergency Stop Categories 1 and 2.

Values are available to be read in Test Mode. If values are read from an activated function the current values are returned, if a function is deactivated the default value is returned.

The Output "Demand" is set to FALSE if the input connected to "Command Source" is FALSE. "Demand" can only be set to TRUE if the input connected to "Command Source" is TRUE and a valid reset has occurred and is still latched. The reset behaviour depends on the state of the input connected to "Reset Source", "Start Reset" and "Auto Reset", for deactivated functions all function outputs are set to false and the algorithm is not run.

An automatic reset is where the function resets when the input connected to "Command Source" goes to TRUE and "Demand" will mirror the state of the input connected to "Command Source" until another error occurs.

If "Start Reset" = OFF **AND** "Auto Reset" = OFF, then a reset signal is always required.

If "Start Reset" = ON **AND** "Auto Reset" = OFF, then a reset signal is always required except once only after system start when an automatic reset will be applied.

If "Start Reset" = OFF **AND** "Auto Reset" = ON, then a reset signal is required only after system start after that and automatic reset will be applied.

If "Start Reset" = ON **AND** "Auto Reset" = ON then a reset signal is never required, an automatic reset will be applied.

The "Start Reset" and "Auto Reset" shall only be activated if it is ensured, via Risk Assessment, that no hazardous situation can occur when the Programmable Electronic System (PES) is started.

SES can be used to monitor both single and two-channel emergency stop buttons. The MiS2x0 inputs are all 2 channels with built in discrepancy timers. For single channel the input channels can be connected.

**Figure 8-10 SES Diagrammatic representation of the Safe Emergency Stop function**

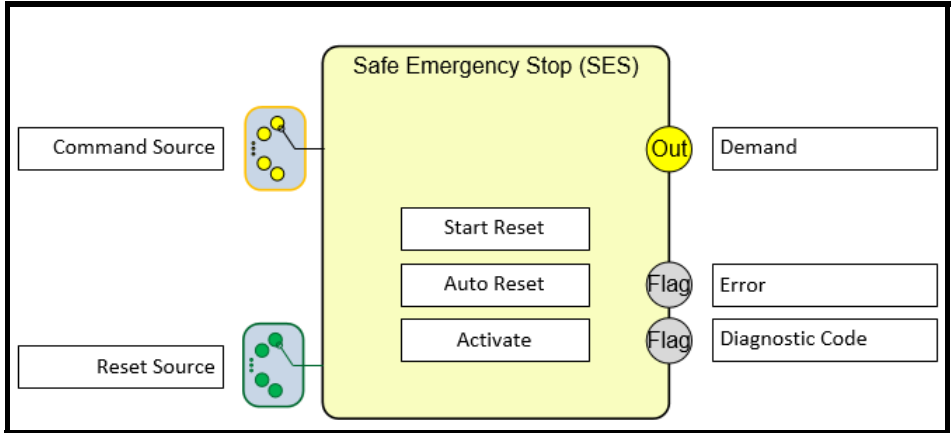

**Standards:**

- EN 418: 1992
- 3. Definitions
- 4.1.12 ... Resetting the control device shall not by itself cause a restart command.
- EN 954-1: 1996
- 5.4 Manual reset
- ISO 12100-2: 2003
- 4.11.4: Restart following power failure/spontaneous restart
- EN 60204-1, 1997
- 9.2.2. Stop Functions

**Number of Instances: 1**

Name	Description
Command Source	Value that will provide the safety demand. This is typically the out value of an input function which in turn connects to a hard-wired input pair or network input for the E-Stop. 0.000: Default (Illegal will cause a configuration error, this must be set by the user) Numeric ID: for a valid Output Connector from another block <u>Value of Source Selected</u> TRUE: No demand for safety-related response, request for operational state (e.g. emergency stop button not engaged). FALSE: Demand for safety-related response (e.g. emergency stop button is engaged).
Demand	Outputs the safety related response of the function FALSE: Demand for safety related response, request for safe state. TRUE: No demand for safety related response, request for operational state
Reset Source	Value that will provide the reset source, typically it will be System Reset but may be connected to any input to control the Reset. 0.001: Disabled, the Auto Reset attribute must be set to on. 0.002: Default, indicating that the function reset should share the System Reset input Numeric ID: From a Non-Safe Boolean Input (BIS) or from a SAFEBOOL if it is also connected to another Safe Output. <u>Value of Source Selected</u> Rising Edge (a change from FALSE to TRUE): The function will be reset if the error condition is no longer present Falling edge or unchanging TRUE or FALSE: No effect

Name	Description
Start Reset	Reset behaviour at System Start OFF: No special reset behaviour at start up (a reset signal is required at start up) ON: One-time automatic reset of the function at start up only A risk assessment on the system must take place and justification provided in the system documentation before this feature is used.
Auto Reset	Reset behaviour after the System Start OFF: No special reset behaviour (reset signal is always required to leave the error state) ON: No reset is required to exit error state (automatic reset will be applied) A risk assessment on the system must take place and justification provided in the system documentation before this feature is used.
Error	Indicates that the function has detected an error condition TRUE: Error, check Diagnostic Code for details FALSE: No Error
Diagnostic Code	Diagnostic Fault Code, visible in Connect in Test Mode (see separate table)
Activate	This parameter is used to activate the function. Connect will set this value to TRUE when an MSF is selected. TRUE: function will be executed FALSE: function is deactivated.

Figure 8-11 SES State Machine

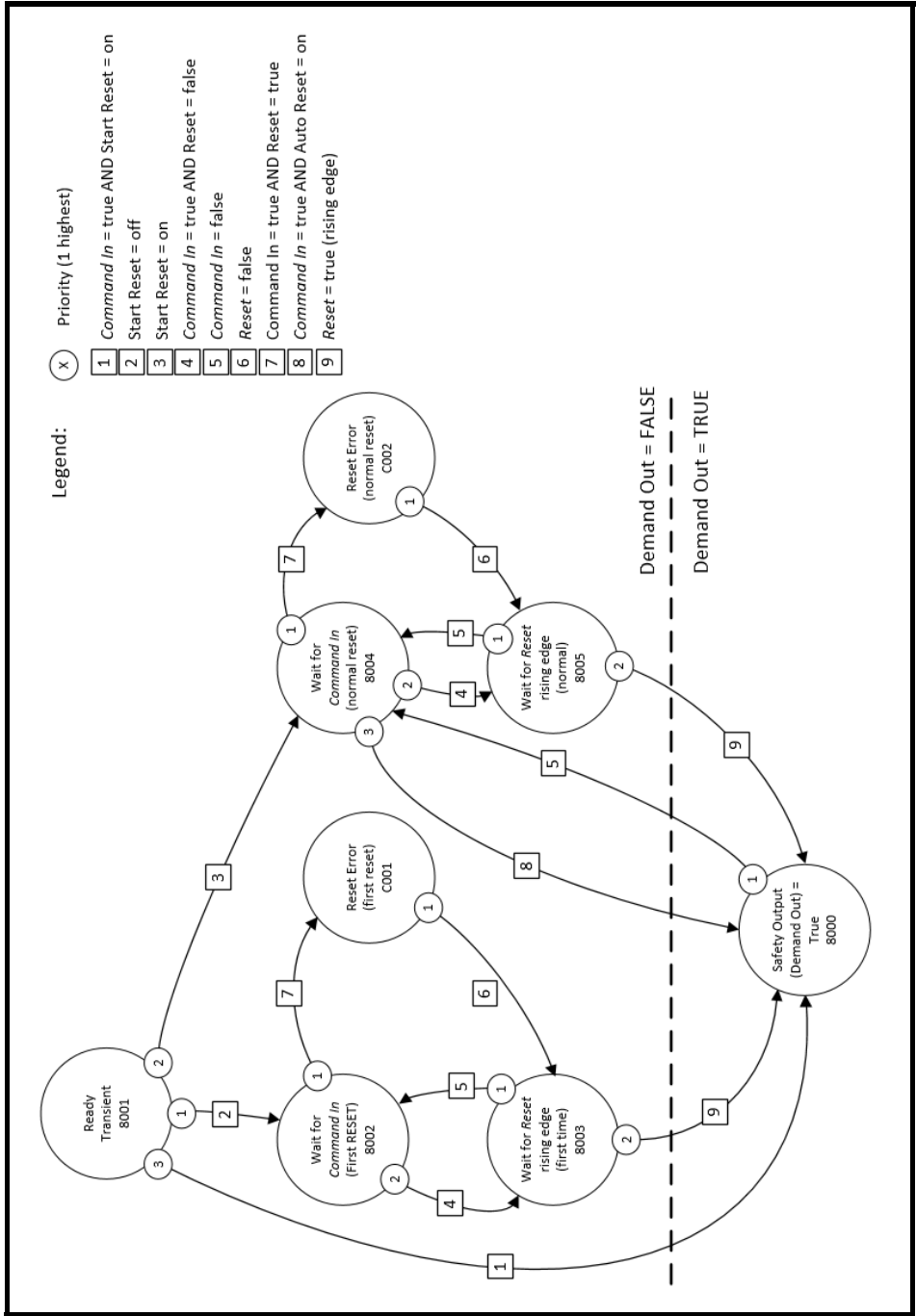

Information
Introduction
Technical Safety Features
Installation
Connect Configuration Tool Introduction
Start Up
Validation
<b>Motion Safety Function Details</b>
Diagnostics and Maintenance
Key Safety Data
Version Control (Amendments)

Figure 8-12 SES timing diagram with Start Reset OFF and Auto Reset OFF, also shows normal Reset error (0xC002)

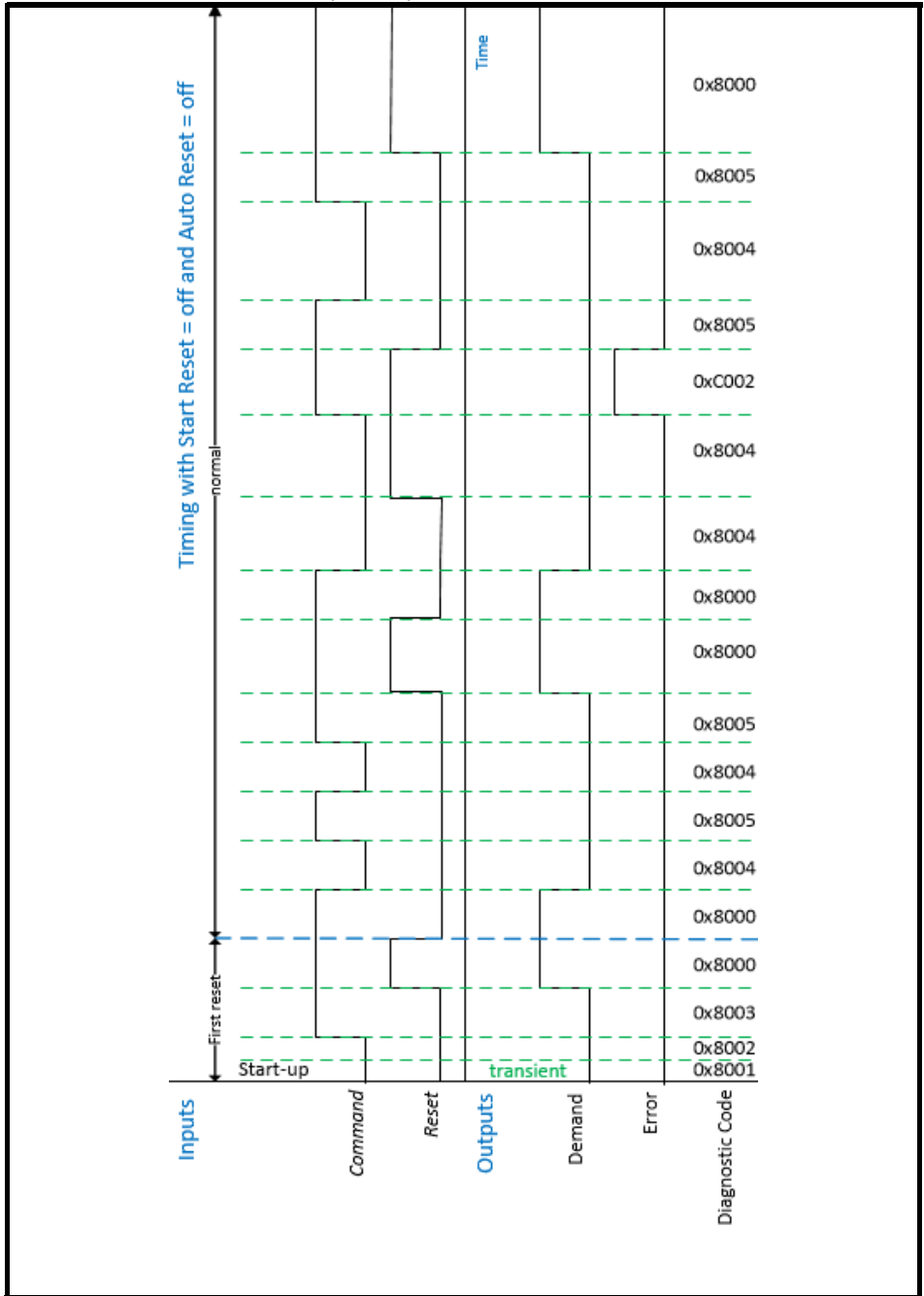
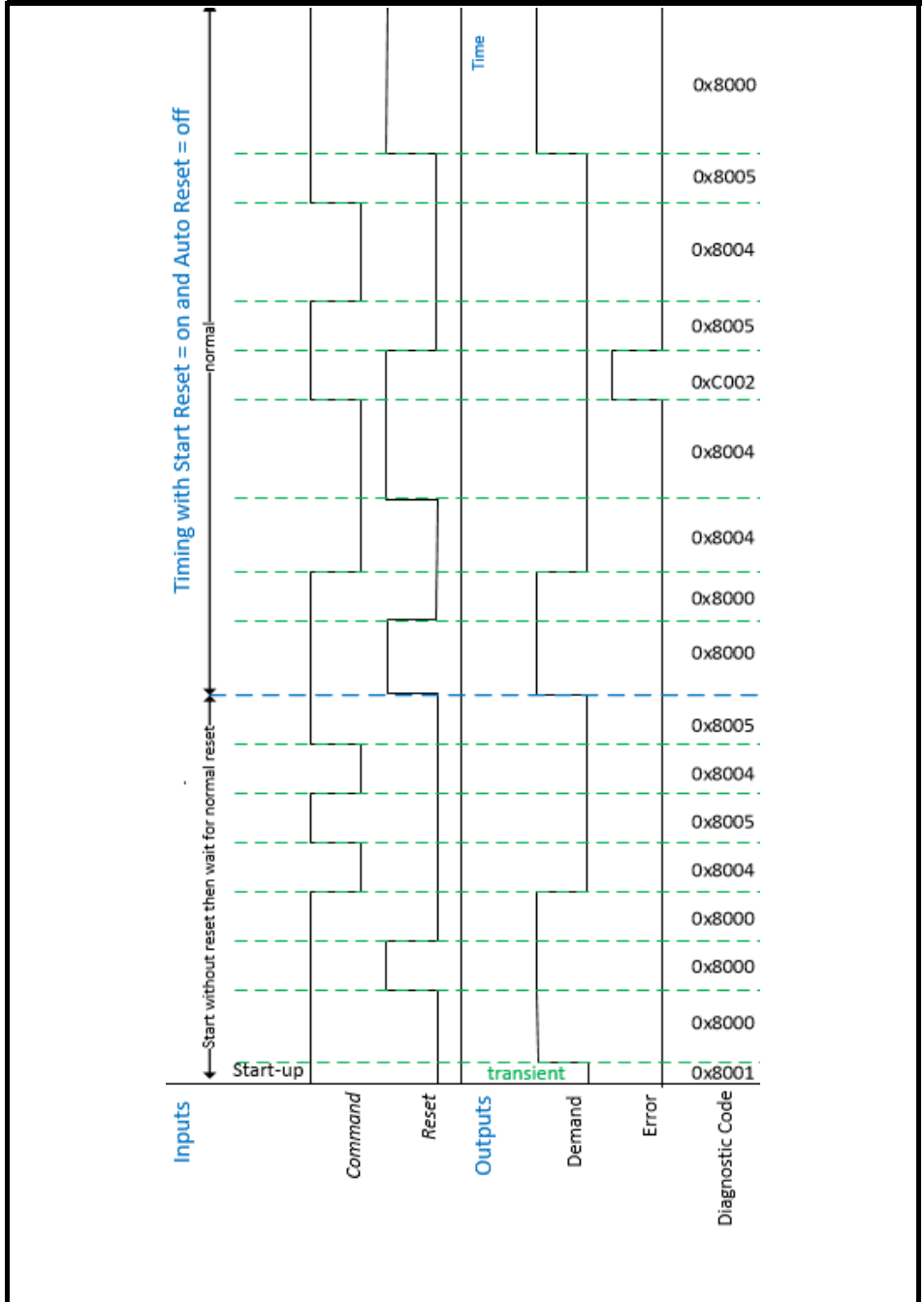
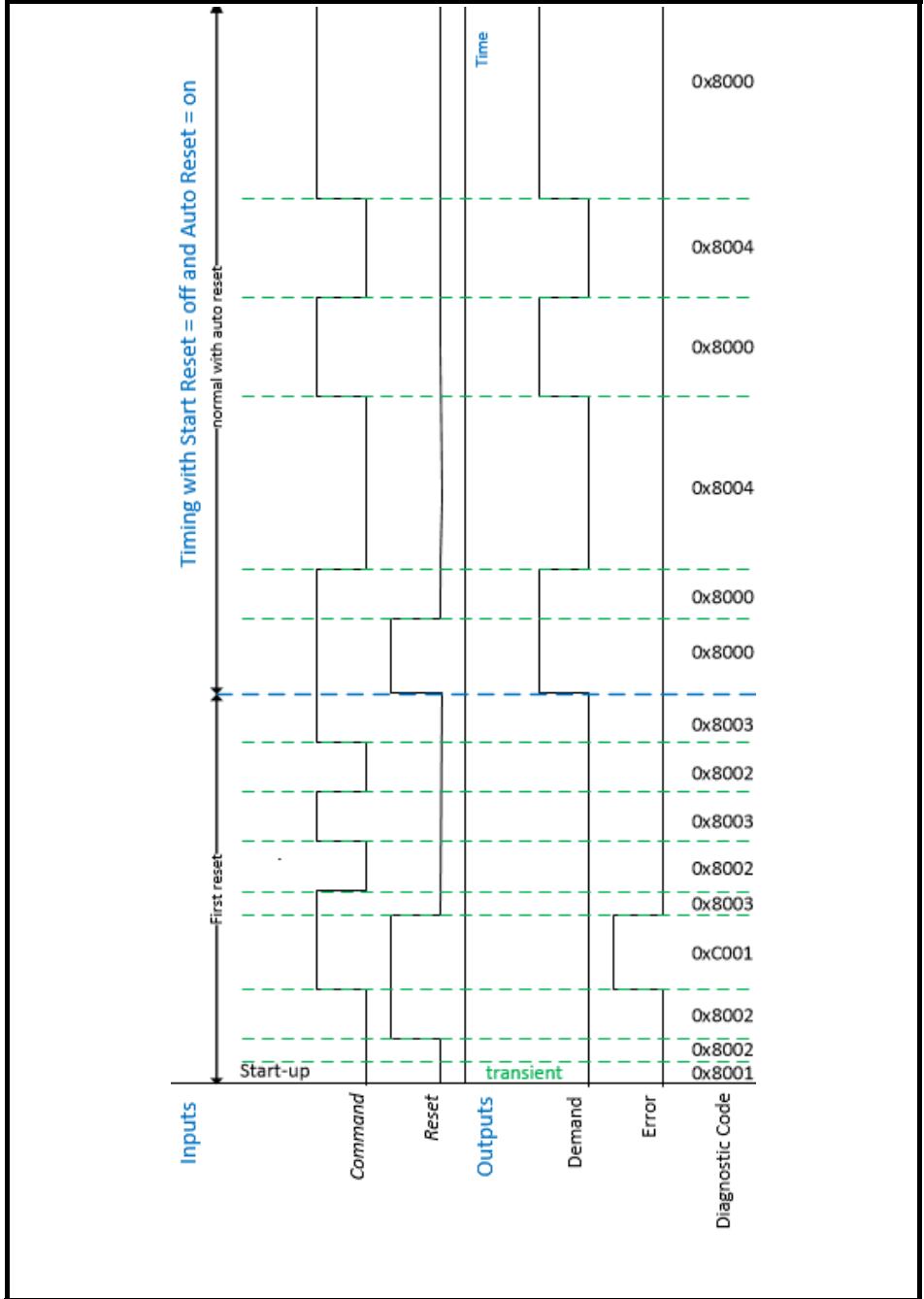

Figure 8-13 SES timing diagram with Start Reset ON, also shows normal Reset error (0xC002)



Information
Introduction
Technical Safety Features
Installation
Connect Configuration Tool Introduction
Start Up
Validation
<b>Motion Safety Function Details</b>
Diagnostics and Maintenance
Key Safety Data
Version Control (Amendments)

Figure 8-14 SES Timing Diagram with Auto Reset ON, also shows First Reset error (0xC001)



DIAGNOSTIC ERRORS – Information for the User		
Code	State	Description
0xC001	Reset Error (first reset)	During wait for first reset, input connected to "Reset Source" signal is TRUE when a rising edge is detected on the input connected to "Command Source". In this state: "Demand" = FALSE, "Error" = TRUE
0xC002	Reset Error (normal reset)	During wait for normal reset, "Reset Source" signal is TRUE when a rising edge is detected on "Command Source". In this state: "Demand" = FALSE, "Error" = TRUE
0x8000	Safety Output "Demand" = TRUE	Input connected to "Command Source" is TRUE and a reset has occurred In this state: "Demand" = TRUE, "Error" = FALSE
0x8001	Ready	Transient state on start-up function moves to one of 0x8000, 0x8002 or 0x8004 depending on state of the input connected to "Command Source" and "Start Reset", see state machine diagram. In this state: "Demand" = FALSE, "Error" = FALSE
0x8002	Wait for Command In (first reset)	Wait for input connected to "Command Source" for go to TRUE, state then transitions to 0x8003. In this state: "Demand" = FALSE, "Error" = FALSE
0x8003	Wait for Reset rising edge (first time)	Wait for the input connected to "Reset Source" to go to TRUE, state then transitions to 0x8000. In this state: "Demand" = FALSE, "Error" = FALSE
0x8004	Wait for Command (normal reset)	Wait for the input connected to "Command Source" for go to TRUE, state then transitions to 0x8003. In this state: "Demand" = FALSE, "Error" = FALSE
0x8005	Wait for Reset rising edge (first time)	Wait for the input connected to "Reset Source" to go to TRUE, state then transitions to 0x8000. In this state: "Demand" = FALSE, "Error" = FALSE

Information

Introduction

Technical Safety Features

Installation

Connect Configuration Tool Introduction

Start Up

Validation

Motion Safety Function Details

Diagnostics and Maintenance

Key Safety Data

Version Control (Amendments)

## 8.8 Safe Stop, SS

The purpose of this function is to monitor the slowdown of the host drive and once the drive is stopped or a given time has been exceeded set its demand output to FALSE. It does not provide any form of control for the drive stop however it does provide an output (Stop Request) which is available to be used to initiate (but not control) the stop when the functions safe input goes FALSE.

**Rate Mode:** The function monitors the slow down to zero speed using an adjustable “Dwell Time”, followed by a segment where the deceleration is monitored. If the envelope is crossed by the speed magnitude the function goes to its error state and sets its “Demand” to FALSE immediately. Under the same conditions, this mode will always detect errors at least as fast as Time mode.

**Figure 8-15 Safe Stop Rate Mode Speed Monitoring Envelope**

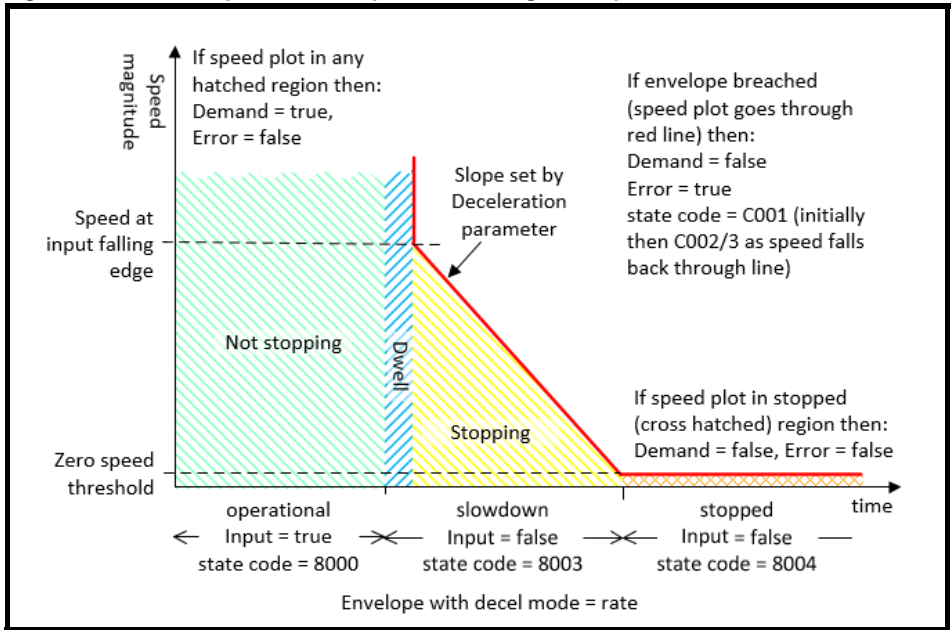

**Time Mode:** The function monitors the slow down to zero speed using an adjustable time "Stop Time". If the envelope is crossed by the speed magnitude the function goes to its error state and sets its "Demand" to FALSE immediately. In addition, if the axis is detected as accelerating the function moves to the error state immediately. This mode should be used if the deceleration rate is not known, and only a maximum time can be given.

**Figure 8-16 Safe Stop Time Mode Speed Monitoring Envelope**

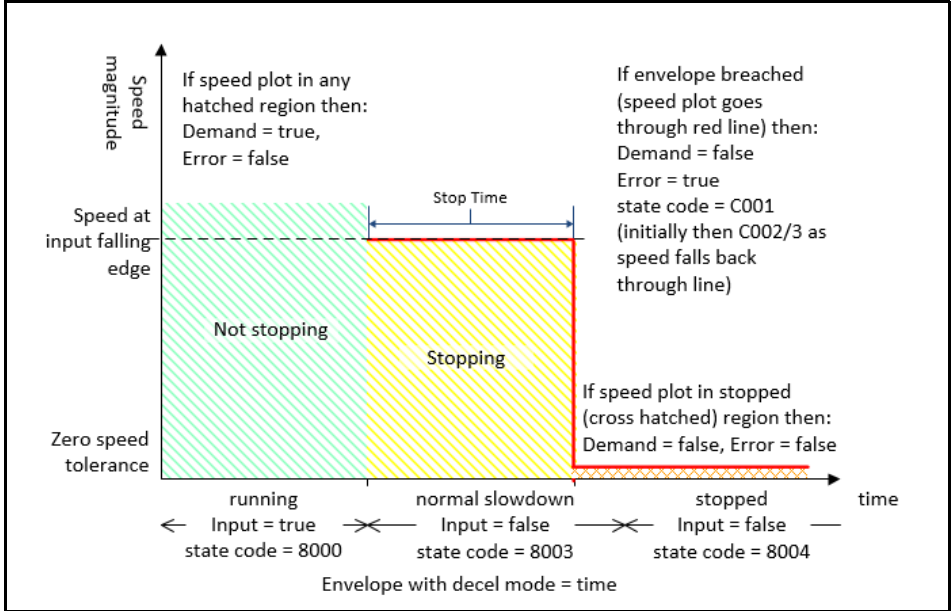

**Errors and Reset:**

If an error occurs the function will set "Demand" to FALSE and will remain in this state until the source of the error clears. The function must then be reset by means of a rising edge applied to the reset input; auto reset is not permitted for this function.

**When the error state is entered, by default in the configuration an alarm will be raised, and all the MiS2x0 Safety Module Safe Outputs will be set to SAFE. If this behaviour is not required by the user then they can disable the alarm generation using the Generate MSF Alarm parameter.**

**Figure 8-17 Diagrammatic representation of the Safe Stop function**

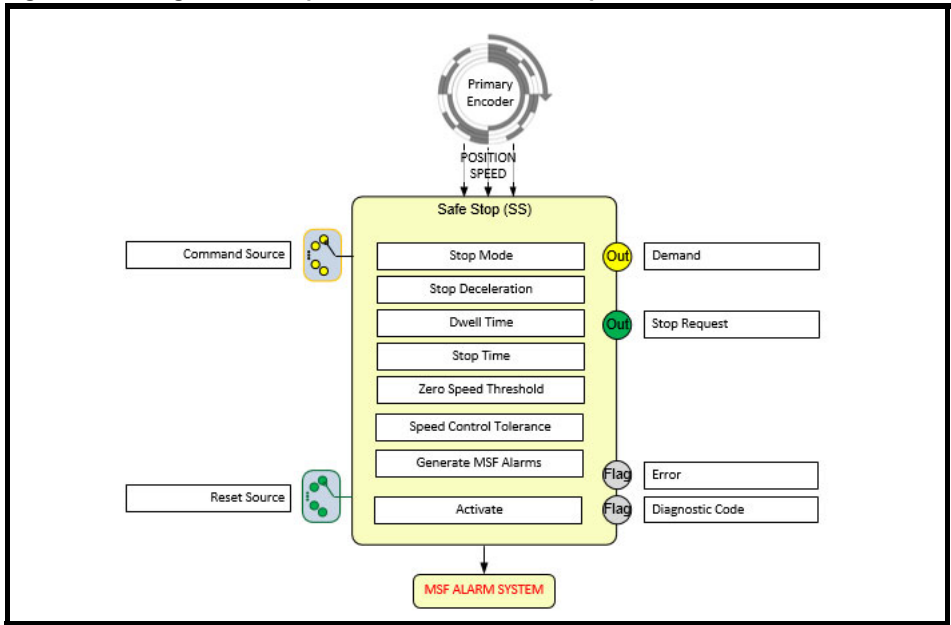

**Standards:**

EN 61800-5-2:2017

4.2.2.3 Safe Stop 1, 4.2.2.3 Safe Stop 2,

For both safety functions defined in the standard this block can be configured to act either in mode or c.

**NOTE**

A simple Safe Stop 1 monitor can be constructed by connecting Safe Stop in series with Safe Torque Off (SS-STO), corresponding to a controlled stop in accordance with stop category 1 of IEC 60204-1 (see section 8.8.1).

A simple Safe Stop 2 monitor can be constructed by connecting Safe Stop in series with Safe Operating Stop and Safe Torque Off probably in parallel with a safety brake, (SS-SOS-(STO+BRAKE)) corresponding to a controlled stop in accordance with stop category 2 of IEC 60204-1 (see section 8.8.2).

IEC 60204-1:2006

9.2.2 Stop Functions

- stop category 1: a controlled stop (see IEC 60204-1:2006, section 3.11) with power available to the machine actuators to achieve the stop and then removal of power when the stop is achieved.
- stop category 2: a controlled stop with power left available to the machine actuators.

**Number of Instances: 2**

Contained within SS1 and SS2 in Connect

Name	Description
Command Source	Value controls whether the function monitors a stop or not. 0.000: Default (illegal will cause a configuration error; this must be set by the user) Numeric ID: for a valid Output Connector from another block <u>Value of Source Selected</u> TRUE: The function is NOT monitoring a stop. FALSE: The function is monitoring a stop and if its stop envelope is exceeded the "Demand" is set to FALSE.
Demand	Outputs the safety related response of the function. FALSE: (((The function's input is FALSE) AND (the axis has stopped)) OR (the function is not initialized) OR (the function has detected an error) OR (is waiting for a reset after an error has cleared)) TRUE: (((The function's input is TRUE) OR ((the function's input is FALSE) AND the axis has not stopped)) AND (the function is initialized AND the function has detected no errors))
Reset Source	Value that will provide the reset source, typically it will be System Reset but may be connected to any input to control the Reset. 0.002: Default, indicating that the function reset should share the System Reset input Numeric ID: From a Non-Safe Boolean Input (BIS) or from a SAFEBOOL if it is also connected to another Safe Output. <u>Value of Source Selected</u> Rising Edge (a change from FALSE to TRUE): The function will be reset if the error condition is no longer present Falling edge or unchanging TRUE or FALSE: No effect
Stop Request	Non-safe output of this function. It provides a signal that could be used to request that the axis stops. TRUE: Axis Stop is Requested FALSE: Stop is not requested
Stop Mode	Selects the function's stop mode. RATE (0): When this function's SAFEBOOL input goes FALSE demanding a safe stop, then a dwell timer and deceleration ramp is applied to allow the axis time to halt before the function's Demand Out is set to FALSE. Note: This mode will detect an envelope breach during slowdown faster than the time mode. TIME (1): When the input goes FALSE demanding a safe stop, then a timer is applied to allow the axis time to reduce speed before the selected level is monitored.
Stop Deceleration (RATE MODE ONLY)	Deceleration that the function will use to monitor the rate mode envelope Deceleration in encoder counts/s <sup>2</sup>
Dwell Time (RATE MODE ONLY)	Amount of time in milliseconds to be inserted into the Rate Envelope, before Deceleration starts to be monitored Time in ms
Stop Time (TIME MODE ONLY)	Time that the function will use to construct the time envelope Time in ms
Zero Speed Threshold	Speed that the function will use for its zero-speed tolerance Zero speed threshold in encoder counts/s.
Speed Control Tolerance	Upper limit on the amount of dither on the speed feedback which the function allows during slowdown, speed limit and zero speed monitoring. <b>NOTE</b> Low values in this parameter may cause timing issues.
Generate MSF Alarm	Determines whether an alarm is raised when an error is detected which triggers all Safe Outputs to go Safe TRUE: Default, Alarm Raised and all safe outputs go SAFE FALSE: No alarm generated; demand output can be chained to another mitigating action
Error	Indicates that the function has detected an error condition TRUE: Error, check Diagnostic Code for details FALSE: No Error

Information
Introduction
Technical Safety Features
Installation
Connect Configuration Tool Introduction
Start Up
Validation
<b>Motion Safety Function Details</b>
Diagnostics and Maintenance
Key Safety Data
Version Control (Amendments)

Name	Description
Diagnostic Code	Diagnostic Fault Code, visible in Connect in Test Mode (see separate table)
Activate	This parameter is used to activate the function. Connect will set this value to TRUE when an MSF is selected. TRUE: function will be executed FALSE: function is deactivated.

**Figure 8-18 SS State Machine**

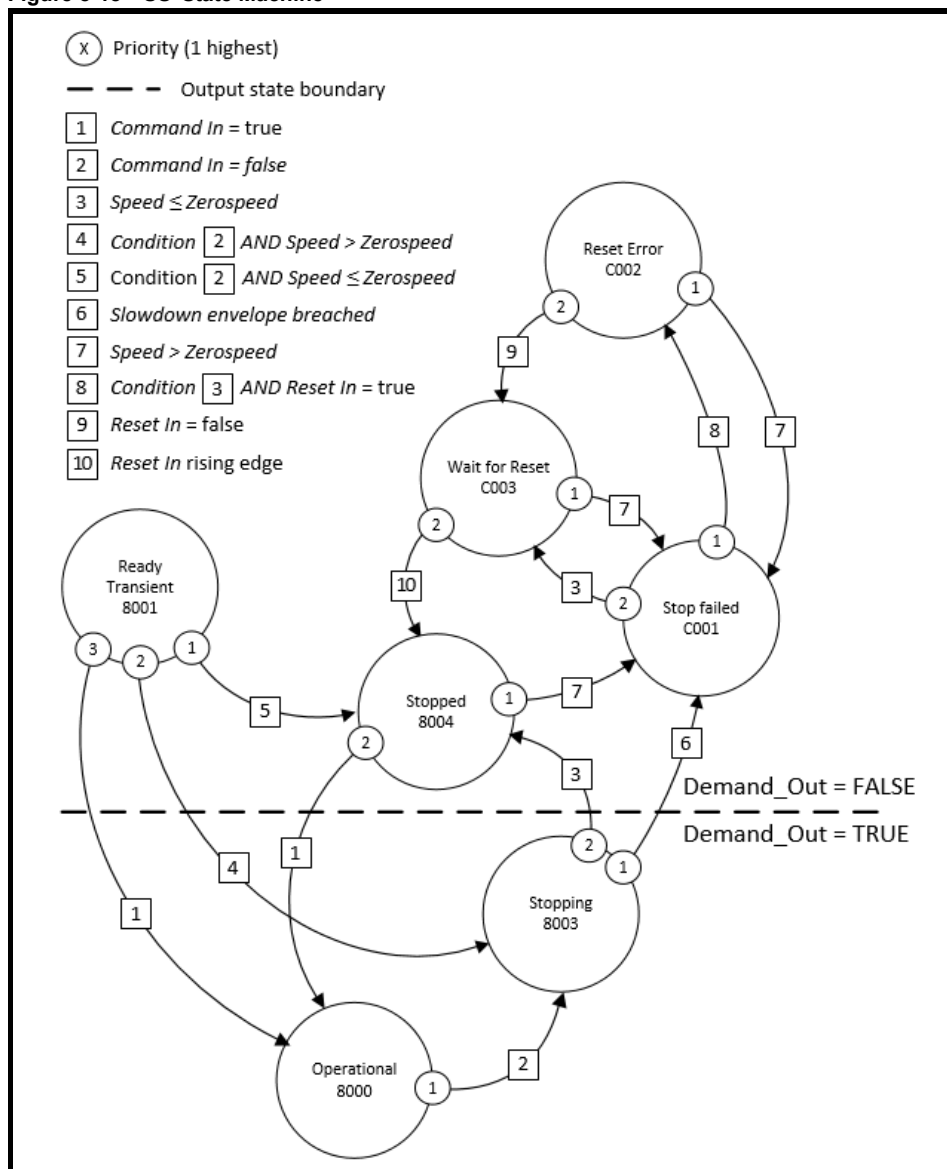

**Figure 8-19** Timing Diagram showing normal and breached ramp mode envelopes and reset behaviour

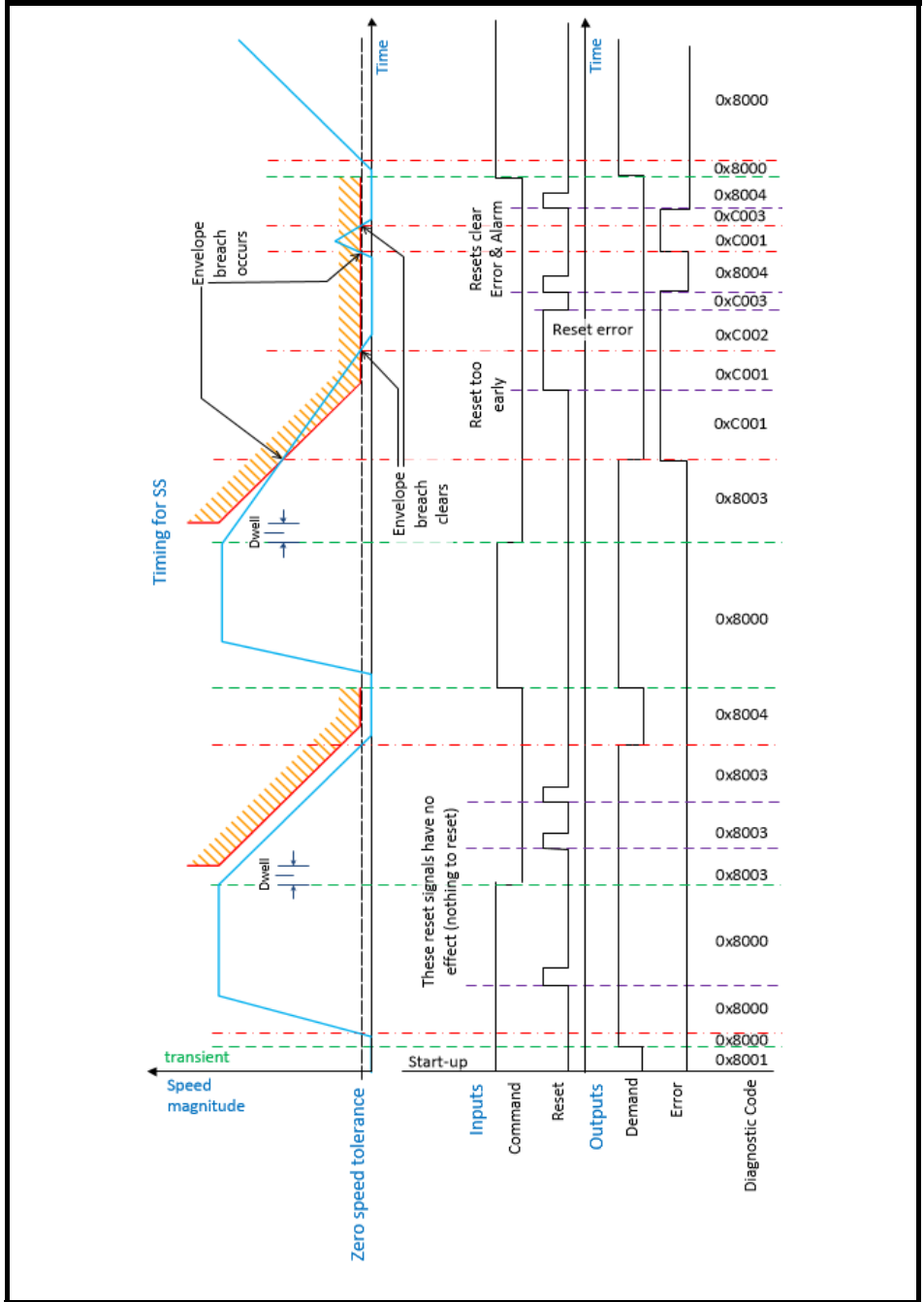

Information
Introduction
Technical Safety Features
Installation
Connect Configuration Tool Introduction
Start Up
Validation
<b>Motion Safety Function Details</b>
Diagnostics and Maintenance
Key Safety Data
Version Control (Amendments)

<b>DIAGNOSTIC ERRORS – Information for the User</b>		
<b>Code</b>	<b>State</b>	<b>Description</b>
C001	Stop Failed	Occurs when the axis speed breaches the slowdown envelope or exceeds the zero-speed threshold value while the input is FALSE. In this state: "Demand" = FALSE
C002	Reset Error	Occurs if the reset signal is high when the C001 error clears. In this state: "Demand" = FALSE
C003	Wait for reset	Occurs after an error state once the error condition has cleared, a rising edge on the error input is required to leave the state. In this state: "Demand" = FALSE
<b>DIAGNOSTIC ERRORS – Information for the User</b>		
0x8000	Operational	Function is operational and not monitoring slowdown or zero speed, to enter this state, Command Source = TRUE. In this state: "Demand" = TRUE
0x8001	Ready	A transient state that occurs for 1 cycle at start up, allows inputs to be checked before any output is set to true. In this state: "Demand" = FALSE
0x8002	Stopping	Function is monitoring the slowdown of the axis, Command Source = FALSE In this state: "Demand" = TRUE
0x8003	Stopped	Function has detected a stop and sets is output false and is monitoring the speed, if the speed goes above the tolerance speed the function will go to Stop Failed error state and an alarm will be raised. To enter this state Command Source = FALSE AND axis stopped. In this state: "Demand" = FALSE

### 8.8.1 Safe Stop 1, SS1

For the Safe Stop 1 functionality Connect automatically configures a connection between the SS and the STO functions. For a full SS1 implementation SES should also be used as the input to this block. This function uses the Connect STO function, so this means that this SS1 is to control the drive that the MiS210 is fitted on via the blade connection. In the case of MiS250 the STO function will be replaced with the SHOS function to allow the user to set up the hardware output.

**If this function is to be chained after SLP, SLS, SLA or SBC then the relevant function needs to have its Generate MSF Alarms parameter set to FALSE to prevent the alarm being raised and all Safe Outputs being set Safe straightaway.**

Figure 8-20 Diagrammatic representation of Safe Stop 1

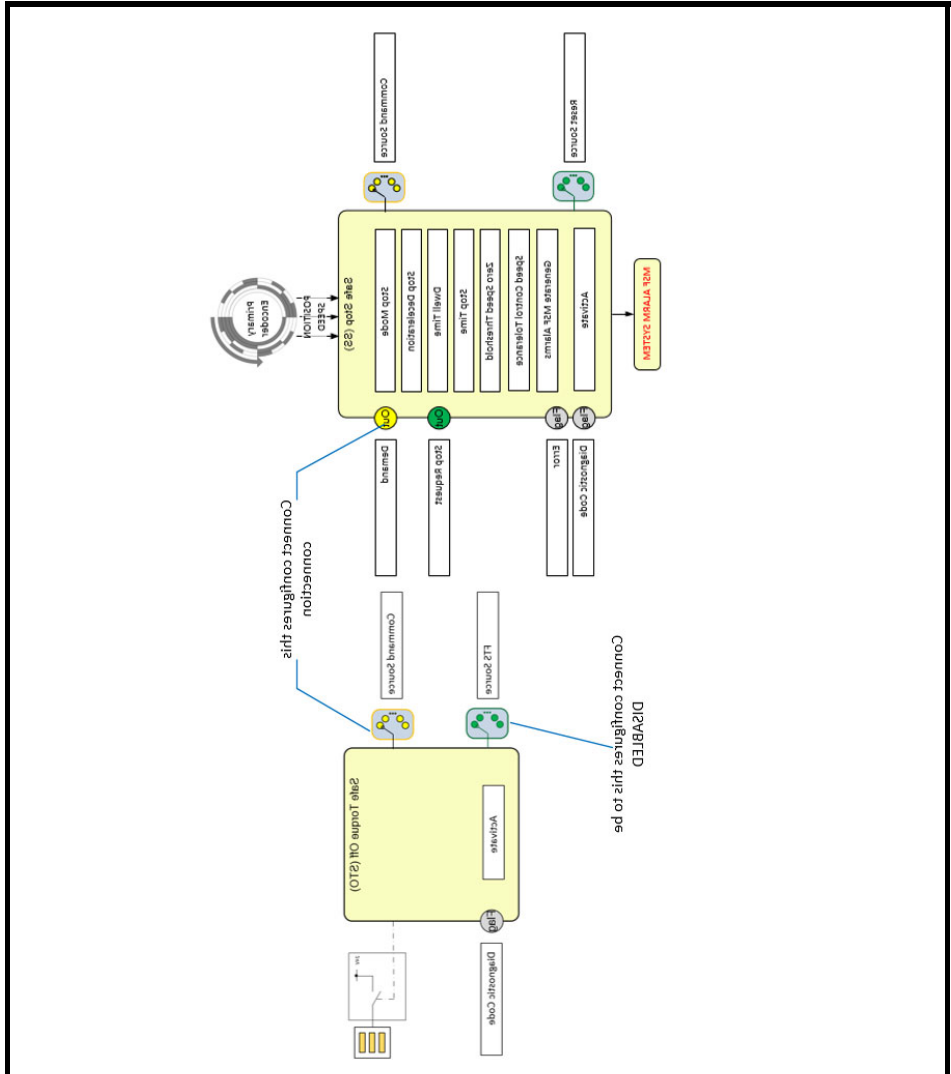

All of the Selectors, Attributes and Outputs related to the SS and STO MSFs are available to be set up for this block within Connect, with the exception of those shown on the diagram above as being specifically configured by Connect.

All of the Errors and Alarms raised by the SS MSF are applicable so if an Alarm is raised by SS due to an envelope breach, all of the Safe Outputs will go Safe straight away. Function Instance Number for SS1 is 151 which will be used any MSF Alarms generated.

### 8.8.2 Safe Stop 2, SS2

For the Safe Stop 2 functionality Connect automatically configures connections between the SS and SOS functions. For a full SS2 implementation SES should also be used as the input to this block.

**If this function is to be chained after SLP, SLS, SLA or SBC then the relevant function needs to have its Generate MSF Alarms parameter set to FALSE to prevent the alarm being raised and all Safe Outputs being set Safe straightaway.**

Figure 8-21 Diagrammatic representation of Safe Stop 2

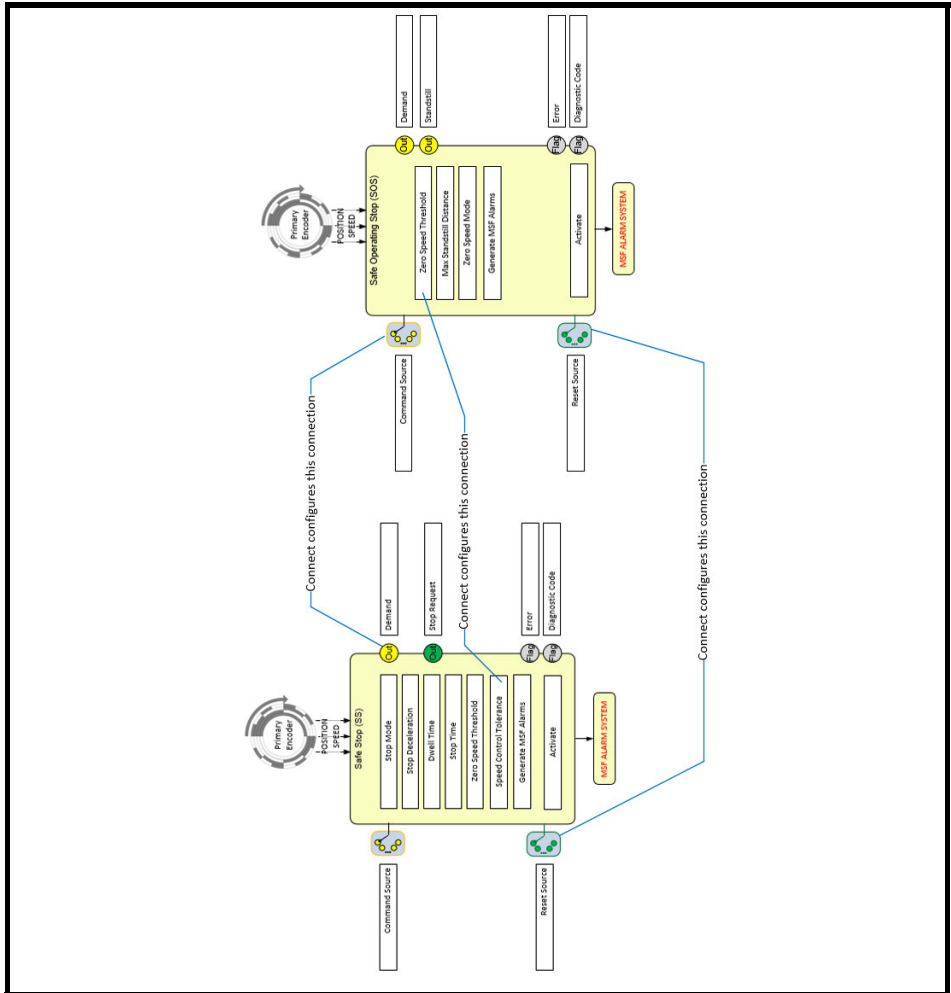

All of the Selectors, Attributes and Outputs related to the SS and SOS MSFs are available to be set up for this block within Connect, with the exception of those shown on the diagram above as being specifically configured by Connect.

All of the Errors and Alarms raised by SS and SOS MSFs are applicable so if an Alarm is raised by SS or SOS due to an envelope breach, all of the Safe Outputs will go Safe straight away. Function Instance Number for SS2 is 152 which will be used any MSF Alarms generated.

## 8.9 Safely Limited Speed, SLS

The purpose of this function is to monitor the speed of the drive, with various additional checks on acceleration and/or time to reach the safe speed and/or zero speed. When the axis reaches a speed above that defined by the active envelope the SLS output will be set to FALSE as the function has entered an error state and a reset will be needed.

This function has 3 different ways to monitor (Immediate, Rate and Time) the axis speed when monitoring is requested and two different types of monitoring (Zero Speed and a Speed Limit).

**Speed Envelope:** is the current monitored speed threshold. If the threshold is exceeded the envelop is breached. Each mode will have its own envelope segments described. Figure 8-22 below shows how the monitoring envelop shape is effected by the current state.

**Figure 8-22 Zero Speed Monitoring**

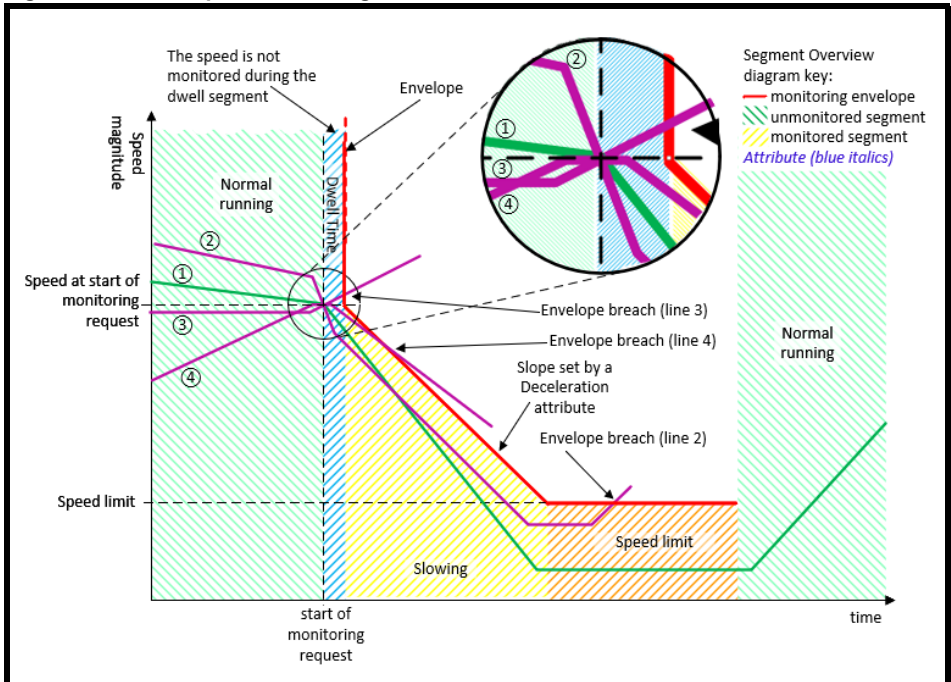

**Zero speed monitoring:** is on if the Zero Speed Command Source is FALSE, (Speed Limit Command Source is ignored). Zero speed monitoring has two modes, the simplest (Speed Mode) checks that the axis speed is below the Zero Speed Threshold and if it is NOT, sets all its outputs to FALSE and enters a latched error state, it will allow the axis to creep and so should not be used if this is a risk. The second is Position Mode, this also checks speeds but adds a position check too so that the axis cannot creep more than the Max Standstill Distance. The axis position is acquired when the axis falls below the zero-speed threshold and the subsequent position is monitored.

**Figure 8-23 Zero speed monitoring**

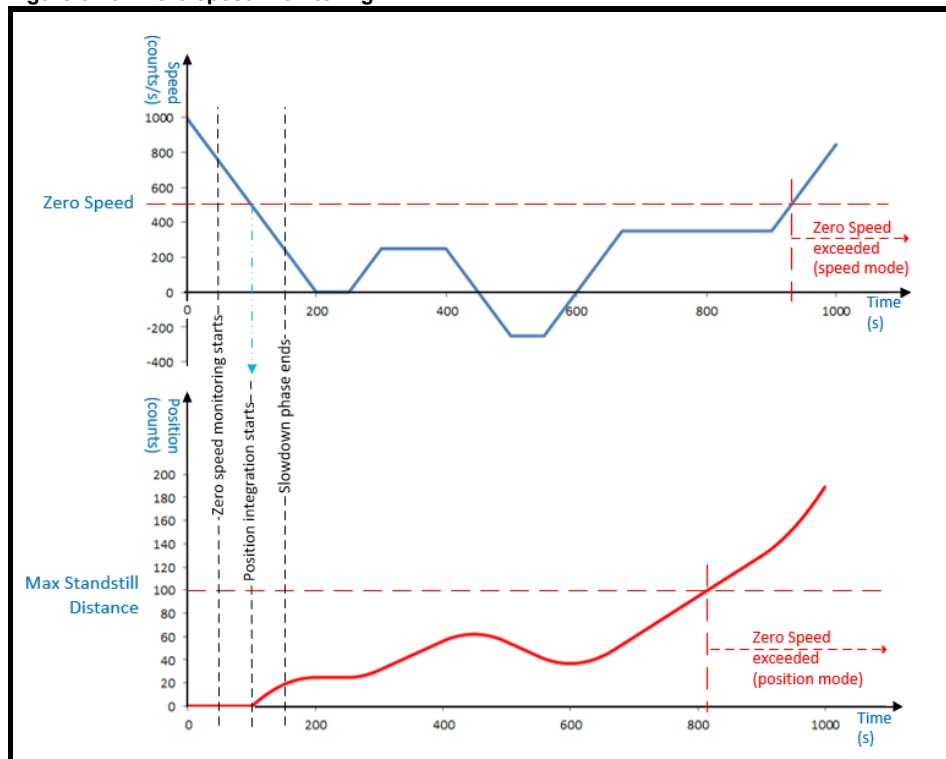

The top graph in Figure 8-23 shows the axis slowing, monitoring starting followed by a monitored slow down, below zero speed threshold operation, and envelope breach is detected at about 930 s. The two graphs in conjunction show speed monitoring with standstill monitoring, zero speed is monitored and used to initialise the standstill position integration, if the allowed displacement occurs (in either direction) then the envelope breach occurs (after about 810 s on the graph).

Zero speed Command Source must be toggled after an MSF alarm to reset the standstill distance.

**Speed Limit Monitoring** is on if the Speed Limit Command Source is FALSE, and the Zero Speed Command Source is TRUE. It checks that the axis speed is below Safe Speed and if it is NOT, sets all outputs to FALSE and enters a latched error state.

**Figure 8-24 Speed Limit Monitoring**

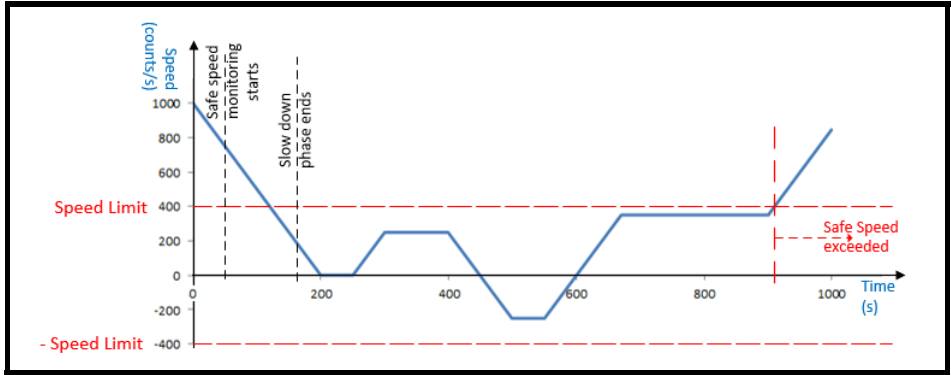

**Immediate Mode:** causes the function to monitor which ever threshold (Zero or Speed Limit) is active immediately allowing no time for the axis to slow down. This mode should be used if the machine control system will slow the machine to the appropriate speed before requesting speed monitoring. If the envelope is crossed the function goes to its error state and sets it Demand Out to FALSE. This mode should always pick up errors faster than Rate mode, however it cannot monitor the slowdown. This mode acts the same as Safe Speed Monitor (SSM) with the exception that this can raise and alarm.

Figure 8-25 shows the operational period between the two monitoring sequences is not required, the function can go directly from monitoring a Speed Limit to Monitoring Zero Speed and vice versa.

**Figure 8-25 Immediate Mode Speed Monitoring Envelope**

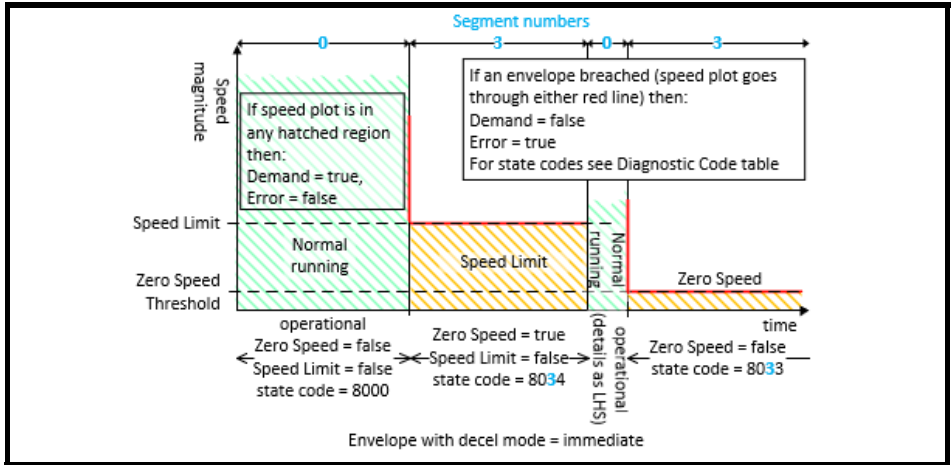

**Rate Mode:** causes the function to monitor which ever threshold (Zero or Speed limit) is active allowing time for the axis to slow down by providing an adjustable dwell time followed by a segment where the deceleration is monitored. This mode should be used if it is the machine control system will slow the machine to the appropriate speed before requesting speed monitoring and the deceleration rate is known. If the envelope is crossed the function goes to its error state and sets it Demand Out to FALSE.

**Figure 8-26 Rate Mode Speed Monitoring Envelope**

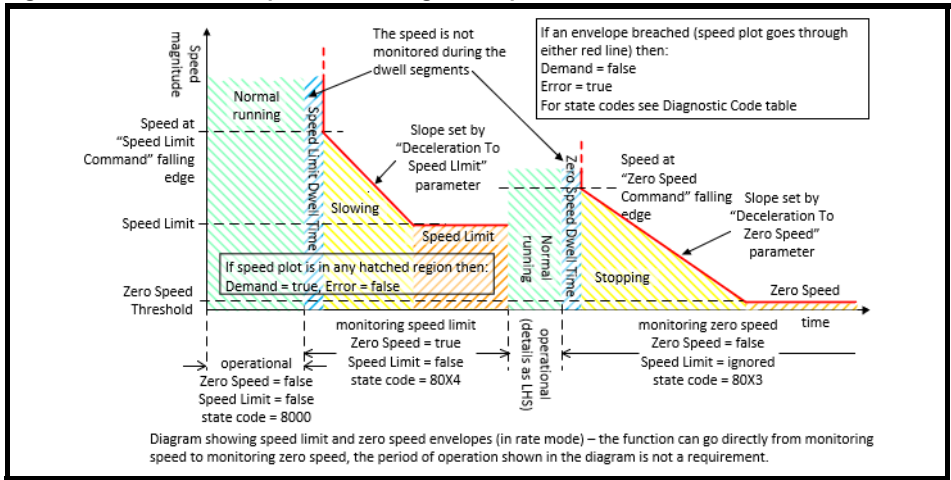
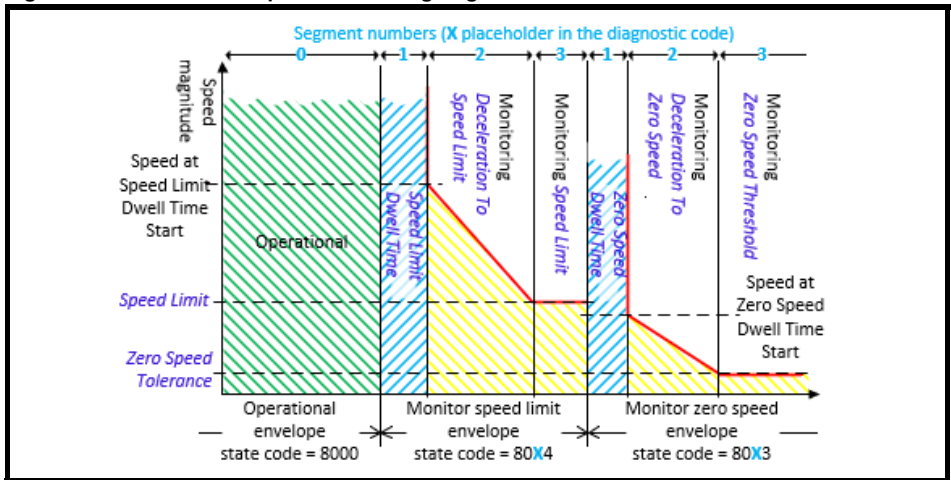

Figure 8-26 Rate Mode Speed Monitoring Envelope, the operational period between the two monitoring sequences is not required, the function can go directly from monitoring a Speed Limit to Monitoring Zero Speed and vice versa

Figure 8-27 below shows the segment codes for the Rate mode. Code 1 for Time Segment (Dwell time), Code 2 for Rate Segment (Deceleration) and Code 3 for Limit Segment.

**Figure 8-27 Rate Mode Speed Monitoring Segment Codes**



**Time Mode:** causes the function to monitor which ever threshold (Zero or Speed Limit) is active allowing time for the axis to slow down to the selected threshold by providing an adjustable slow down time. This mode should be used if the machine control system will not slow the machine to the appropriate speed before requesting speed monitoring and the deceleration rate is unknown or variable, and only a maximum time can be given. If the envelope is crossed the function goes to its error state and sets its Demand Output to FALSE. In addition, if the axis is detected as accelerating the function moves to the error state immediately.

**Figure 8-28 Time Mode Speed Monitoring Envelope**

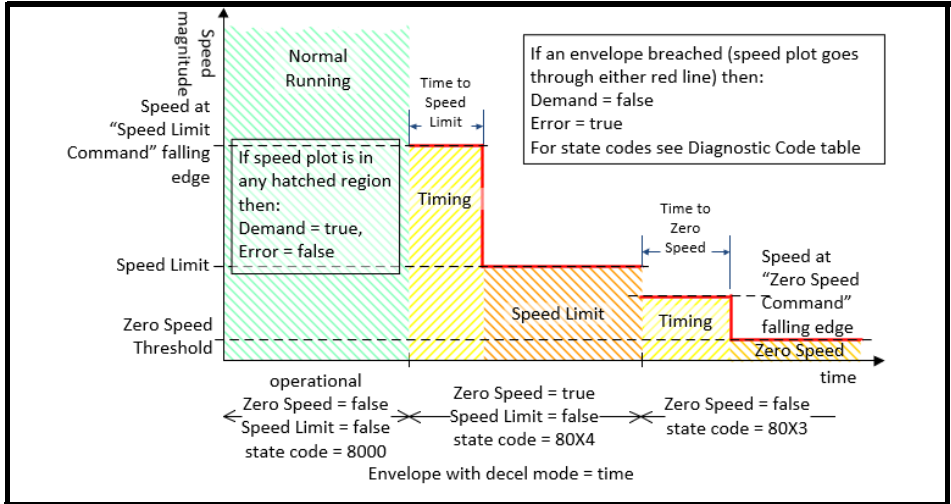
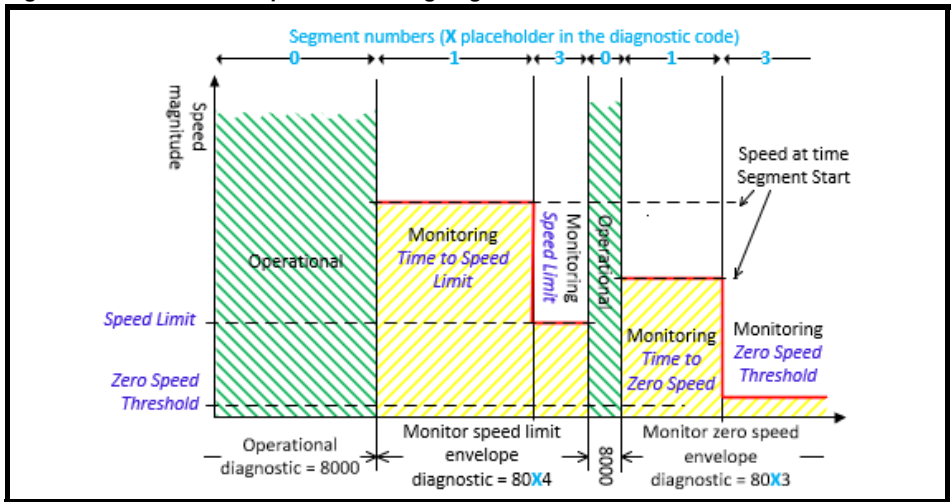

Figure 8-29 below shows the segment codes for the Time mode. Code 1 for Time Segment (Dwell & Deceleration time) and Code 3 for Limit Segment.

**Figure 8-29 Time Mode Speed Monitoring Segment Codes**



## Errors and Reset:

If an error occurs the function will set "Demand" to FALSE and will remain in this state until the source of the error clears. The function must then be reset by means of a rising edge applied to the reset input; auto reset is not permitted for this function.

**When the error state is entered, by default in the configuration an alarm will be raised, and all the MiS2x0 Safety Module Safe Outputs will be set to SAFE. If this behaviour is not required by the user then they can disable the alarm generation using the Generate MSF Alarm parameter.**

**Figure 8-30 Diagrammatic representation of the Safely Limited Speed function**

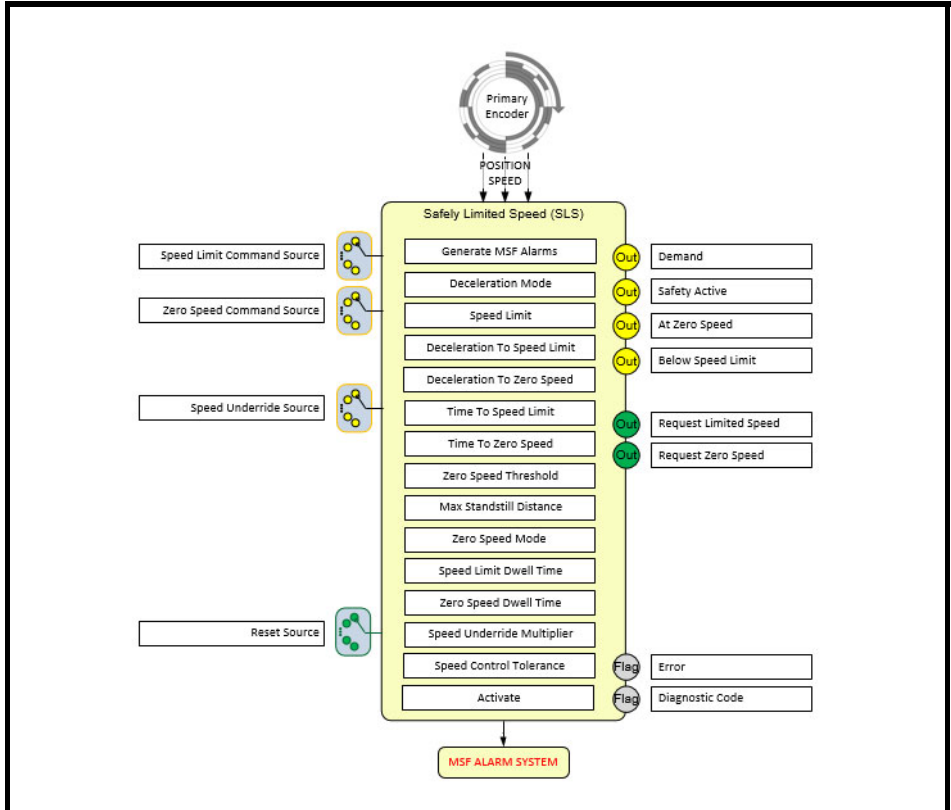

## Standards:

IEC 61800-5-2: 2017

### 4.2.3.4 Safely-Limited Speed (SLS)

The SLS function prevents the motor from exceeding the specified speed limit.

IEC 60204-1 Ed 5: 2003

### 9.2.6.3 Enabling control

Enabling control (see also 10.9) is a manually activated control function interlock that:

- when activated allows a machine operation to be initiated by a separate start control, and
- when de-activated
  - initiates a stop function, and
  - prevents initiation of machine operation.

IEC 954-1: 1996

5.4 Manual reset

ISO 12100-2: 2003

4.11.4: Restart following power failure/spontaneous restart

**Number of Instances: 4**

Name	Description
Speed Limit Command Source	<p>Value controls whether the function monitors for a safe speed or not.            0.000: Default (illegal will cause a configuration error; this must be set by the user)            0.001: Disabled, turns off Speed Limit Monitoring, if this input is disabled, then "Zero Speed Command Source" MUST be enabled.            Numeric ID: for a valid Output Connector from another block.  <u>Value of Source Selected</u>            TRUE: The function is NOT monitoring a Safe Speed Limit, if Zero Speed Command Source is also TRUE, "Demand" is set to TRUE.            FALSE: The function is monitoring a Safe Speed Limit and if its envelope is exceeded, "Demand" is set to FALSE.</p> <p><b>NOTE</b></p> <p>The Zero Speed Command Source takes precedence over this input, if it is FALSE then the Zero Speed Threshold is monitored, and the value of this input is ignored.</p>
Zero Speed Command Source	<p>Value controls whether the function monitors for zero speed or safe speed.            0.000: Default (Illegal will cause a configuration error, this selector must be set by the user)            0.001: Disabled, turns off Zero Speed Monitoring, if this input is disabled, then "Speed Limit Command Source" MUST be enabled.            Numeric ID: for a valid Output Connector from another block.  <u>Value of Source Selected</u>            TRUE: The function is NOT monitoring for a Zero Speed Threshold, if the Speed Limit Command Source is also TRUE the "Demand" is set to TRUE            FALSE: The function is monitoring for a Zero Speed Threshold and if its envelope is exceeded, "Demand" is set to FALSE.</p> <p><b>NOTE</b></p> <p>The Speed Limit Command Source is ignored if the Zero Speed Command Source is FALSE</p>
Demand	<p>Outputs the safety related response of the function.            TRUE: The function is initialized and has detected no errors.            FALSE: The function is not initialized OR has detected an error OR is waiting for a reset after an error has cleared.</p>
Safety Active	<p>Provides a safe signal to indicate if any monitoring is active and the monitored axis passes the active envelope testing, its use is optional, and it may be left disconnected.            TRUE: The function is initialized AND monitoring for a threshold AND there are no errors.            FALSE: The function is not initialized OR has detected an error OR is above both the thresholds OR is not monitoring.</p>
At Zero Speed	<p>Provides a safe signal to indicate if the zero-speed monitoring is active, and the monitored axis passes the zero speed envelope testing, its use is optional and it may be left disconnected.            TRUE: The function is initialized AND is monitoring zero speed AND there are no errors.            FALSE: The function is not initialized OR has detected an error OR is above zero speed OR is not monitoring.</p>
Below Speed Limit	<p>Provides a safe signal to indicate if the safe speed monitoring is active and the monitored axis passes the safe speed envelope testing (including any override), its use is optional, and it may be left disconnected.            TRUE: The function is initialized AND is monitoring safe speed AND there are no errors.            FALSE: The function is not initialized OR has detected an error OR is above safe speed OR is not monitoring.</p>

Information
Introduction
Technical Safety Features
Installation
Connect Configuration Tool Introduction
Start Up
Validation
<b>Motion Safety Function Details</b>
Diagnostics and Maintenance
Key Safety Data
Version Control (Amendments)

Name	Description
Reset Source	<p>Value that will provide the reset source, typically it will be System Reset but may be connected to any input to control the Reset.</p> <p>0.002: Default, indicating that the function reset should share the System Reset input</p> <p>Numeric ID: From a Non-Safe Boolean Input (BIS) or from a SAFEBOOL if it is also connected to another Safe Output.</p> <p><u>Value of Source Selected</u></p> <p>Rising Edge (a change from FALSE to TRUE): The function will be reset if the error condition is no longer present</p> <p>Falling edge or unchanging TRUE or FALSE: No effect</p>
Request Limited Speed	<p>Non-safe output of this function. It provides a signal that could be used to request that the axis slows to below limited speed.</p> <p>TRUE: The axis should go to below safe speed.</p> <p>FALSE: Below safe speed is not requested (but zero speed may be).</p>
Request Zero Speed	<p>Non-safe output of this function. It provides a signal that could be used to request that the axis slows to zero speed.</p> <p>TRUE: The axis should go to zero speed.</p> <p>FALSE: Below safe speed is not requested (but limited speed may be).</p>
Deceleration Mode	<p>Selects the function's deceleration mode.</p> <p>IMMEDIATE (0): When the monitoring inputs request speed monitoring the selected level is applied immediately</p> <p>RATE (1): When the monitoring inputs request speed monitoring, a dwell timer and deceleration ramp is applied to allow the axis time to reduce speed before the selected level is monitored. Note: This mode will detect an envelope breach during slowdown faster than the time mode.</p> <p>TIME (2): When the monitoring inputs request speed monitoring, then a timer is applied to allow the axis time to reduce speed before the selected level is monitored.</p>
Speed Limit	<p>Speed that the function will use for its speed limit, unless it is under-ridden by the Speed Underride Input and its multiplier, if this is the case then this parameter acts as an upper limit on the Speed Underride Input.</p> <p>Safe speed in encoder counts/s</p>
Deceleration To Speed Limit (RATE MODE ONLY)	<p>Deceleration that the function will use to construct the rate envelope to a given limit.</p> <p>Deceleration in encoder counts/s<sup>2</sup></p> <p>Minimum value is 1000.</p>
Deceleration To Zero Speed (RATE MODE ONLY)	<p>Deceleration that the function will use to construct the rate envelope to zero.</p> <p>Deceleration in encoder counts/s<sup>2</sup></p> <p>Minimum value is 1000.</p>
Time To Speed Limit (TIME MODE ONLY)	<p>Time that the function will use to construct the time envelope to a given limit.</p> <p>Time in s</p>
Time To Zero Speed (TIME MODE ONLY)	<p>Time that the function will use to construct the time envelope to zero.</p> <p>Time in s</p>
Zero Speed Threshold	<p>Speed that the function will use for its zero-speed tolerance and standstill monitoring</p> <p>Zero speed threshold in encoder counts/s</p>
Max Standstill Distance	<p>Maximum creep distance (relative to the position at which the axis dropped below the Zero Speed Threshold) allowed when Zero Speed Mode is set to position, ignored if speed.</p> <p>Distance encoder counts.</p>
Zero Speed Mode	<p>Controls the function behavior at speeds below the Zero Speed Threshold.</p> <p>SPEED (0): When the axis speed is monitored, if it exceeds the Zero Speed Threshold then the Demand Output is set to false. When a slowdown phase is active in time mode then the function checks that the speed does not increase over each cycle. A parameter Speed Control Tolerance is provided to allow small speed control oscillations to be ignored.</p> <p>POSITION (1): When the axis speed and standstill distances are monitored, if either the speed exceeds the Zero Speed Threshold, or the Relative position exceeds the Standstill Distance then the Demand Output is set to false.</p>

Name	Description
Speed Limit Dwell Time (RATE MODE ONLY)	Amount of time to be inserted into the Rate Envelope before Deceleration to a given limit starts to be monitored. Time in ms
Zero Speed Dwell Time (RATE MODE ONLY)	Amount of time in milliseconds to be inserted into the Rate Envelope before Deceleration to zero starts to be monitored. Time in ms
Speed Underride Multiplier	Works in conjunction with Speed Underride Source, it allows the underride input to be scaled up to match the internal 64 bit speed value. The minimum value is 1. <b>NOTE</b> This feature will typically only be required if the Speed Limit value is greater than 232
Speed Control Tolerance	Upper limit on the amount of dither on the speed feedback which the function allows during slowdown, speed limit and zero speed monitoring.
Generate MSF Alarm	Determines whether an alarm is raised when an error is detected which triggers all Safe Outputs to go Safe TRUE: Default, Alarm Raised and all safe outputs go SAFE FALSE: No alarm generated; demand output can be chained to another mitigating action
Speed Underride Source	Provides a value to reduce the speed limit below the value in the Speed Limit attribute but not increase the speed limit above this value. The value can only be selected from a 32bit Safety Network input. A 32 bit multiplier is provided so that the input can (if necessary) be scaled up to match the internal 64 bit speed value. The selected value <b>MUST</b> be positive. 0.001: Default, disables the Speed Underride Input and the function will use the "Speed Limit" attribute value as the limit. Numeric ID: for a valid SAFEINT output connector.
Error	Indicates that the function has detected an error condition. TRUE: Error, check "Diagnostic Code" for details. FALSE: No Error.
Diagnostic Code	Diagnostic Fault Code, visible in Connect in Test Mode (see separate table)
Activate	This parameter is used to activate the function. Connect will set this value to true when an MSF is selected. TRUE: function will be executed. FALSE: function is deactivated.

Information

Introduction

Technical Safety Features

Installation

Connect Configuration Tool Introduction

Start Up

Validation

Motion Safety Function Details

Diagnostics and Maintenance

Key Safety Data

Version Control (Amendments)

**Figure 8-31 State Machine**

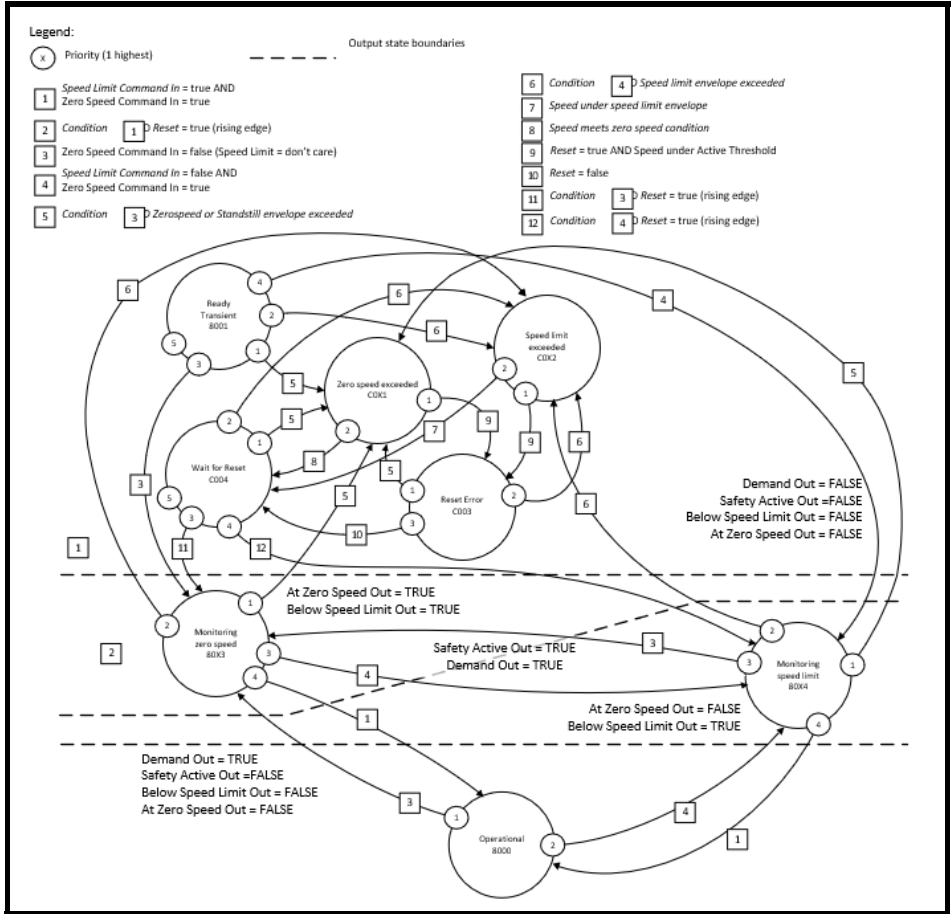
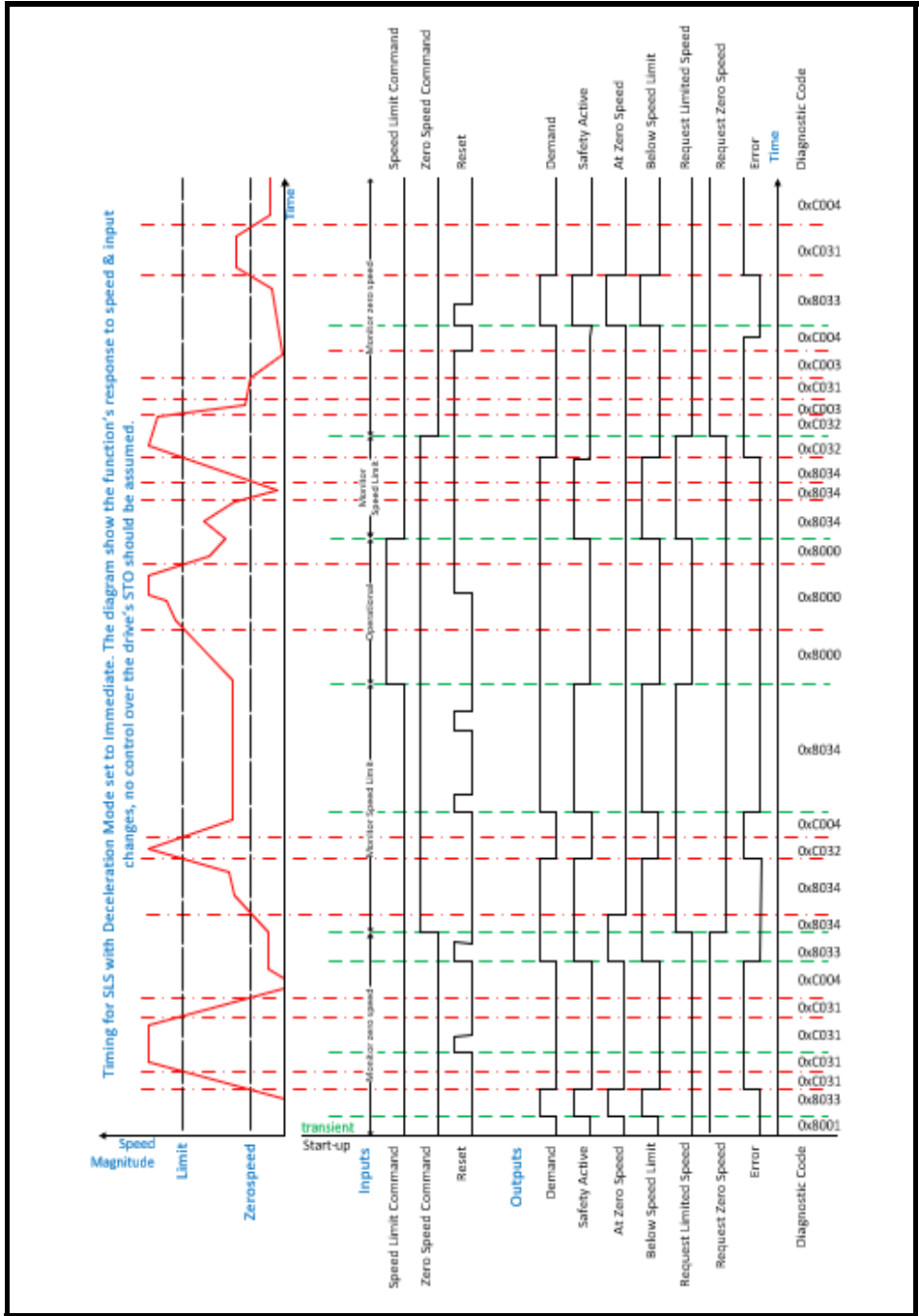

Figure 8-32 Timing Diagram - Immediate mode



Information	Introduction	Technical Safety Features	Installation	Connect Configuration Tool Introduction	Start Up	Validation	<b>Motion Safety Function Details</b>	Diagnoses and Maintenance	Key Safety Data	Version Control (Amendments)
-------------	--------------	---------------------------	--------------	---	----------	------------	---------------------------------------	---------------------------	-----------------	------------------------------



Figure 8-34 Timing Diagram - Rate mode

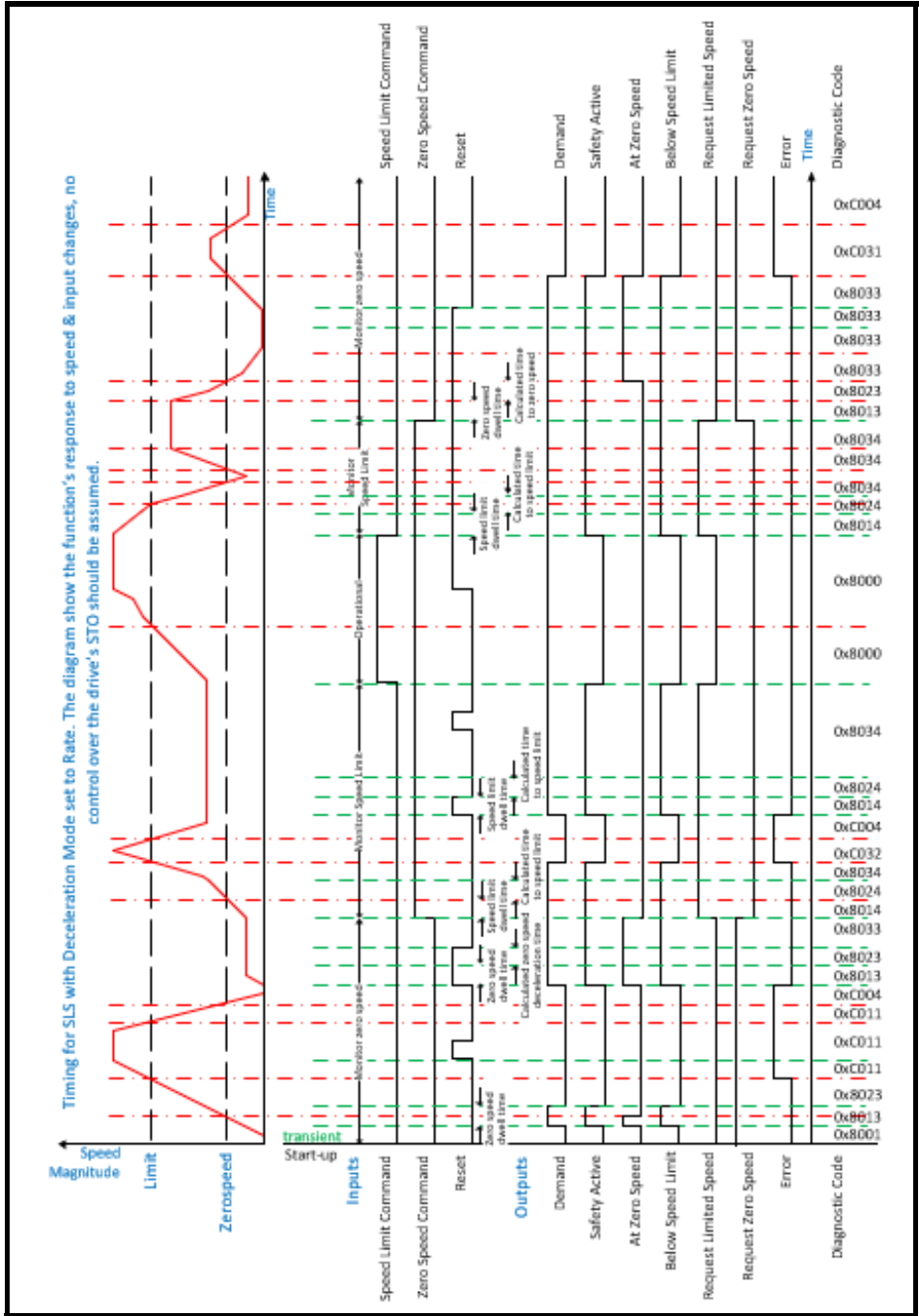

Information
Introduction
Technical Safety Features
Installation
Connect Configuration Tool Introduction
Start Up
Validation
<b>Motion Safety Function Details</b>
Diagnostics and Maintenance
Key Safety Data
Version Control (Amendments)

**ERRORS THAT CAN TRIGGER ALARMS - ALL SAFE OUTPUTS GO SAFE**

Code	State	Description
0xC0X1	Zero Speed Threshold Exceeded	Occurs when the axis speed exceeds the zero-speed threshold value or if configured the standstill distance, whichever comes first. The X in the code is a 4bit value that can be used to determine in which envelope segment the error occurred In this state: "Demand" = FALSE, "Safety Active" = FALSE, "Below Speed Limit" = FALSE, "At Zero Speed" = FALSE
0xC0X2	Safe Speed Threshold Exceeded	Occurs when the axis speed exceeds the safe speed threshold value. The X in the code is a 4bit value that can be used to determine in which envelope segment the error occurred. In this state: "Demand" = FALSE, "Safety Active" = FALSE, "Below Speed Limit" = FALSE, "At Zero Speed" = FALSE
0xC003	Reset Error	Occurs if the reset signal is high when the C0X1 or C0X2 error clears. In this state: "Demand" = FALSE, "Safety Active" = FALSE, "Below Speed Limit" = FALSE, "At Zero Speed" = FALSE
0xC004	Wait for Reset	Occurs after an error state once the error condition has cleared, a rising edge on the error input is required to leave the state. In this state: "Demand" = FALSE, "Safety Active" = FALSE, "Below Speed Limit" = FALSE, "At Zero Speed" = FALSE
<b>DIAGNOSTIC ERRORS – Information for the User</b>		
0x8000	Operational	Function is not monitoring speed and axis may run at full speed, to enter this state Speed Limit Command Source = TRUE and Zero Speed Command Source = TRUE. In this state: "Demand" = TRUE, "Safety Active" = FALSE, "Below Speed Limit" = FALSE, "At Zero Speed" = FALSE
0x8001	Ready	A transient state that occurs for 1 cycle at start up, allows inputs to be checked before any output is set to true. In this state: "Demand" = FALSE, "Safety Active" = FALSE, "Below Speed Limit" = FALSE, "At Zero Speed" = FALSE
0x80X3	Monitoring Zero Speed	Function is monitoring zero speed and axis should be stationary, as defined by the zero speed thresholds and mode attributes. The X in the code is a 4bit value that can be used to determine in which envelope segment axis is currently in. To enter this state Speed Limit Command Source = IGNORED and Zero Speed Command Source = FALSE. In this state: "Demand" = TRUE, "Safety Active" = TRUE, "Below Speed Limit" = TRUE, "At Zero Speed" = TRUE
0x80X4	Monitoring Safe Speed	Function is monitoring the safe speed limit and axis speed should be below the safe speed threshold, as defined by the safe speed threshold and mode attributes. The X in the code is a 4bit value that can be used to determine in which envelope segment axis is currently in. To enter this state Speed Limit Command In Source = FALSE and Zero Speed Command In Source = TRUE In this state: "Demand" = TRUE, "Safety Active" = TRUE, "Below Speed Limit" = TRUE, "At Zero Speed" = FALSE

## 8.10 Safe Two-Handed Control Type 3, STHC3

This function provides the two-hand control functionality according to EN 574, Section 4 Type III with additional options to disable Auto Reset and set Delayed Restart. When Auto Reset is ON and Delay Restart Time is set to zero, the function operates as standard two-hand control Type III (described in EN 574, Section 4). The function waits for input in "Monitor Btn1 and Btn2" state, if "Button 1" and "Button 2" inputs are set to TRUE within 500 ms and in correct engage sequence the function will enter "Operational" state and "Demand" output will be set to TRUE.

The function also covers a release sequence of Button 1 and 2 - both Button inputs need to be set to FALSE before function can re-enter "Monitor" state.

It is recommended to use this function with conjunction with two Safe Not Equivalent instances (for category 3 or 4 two antivalent contacts are needed).

At startup both Button inputs should be FALSE, otherwise the function will enter "Release Sequence".

In the engagement sequence if the discrepancy of the Button inputs exceeds 500 ms the function will enter error state, to leave this state both Button inputs need to be set to FALSE. Discrepancy Time is the time during which "Button 1" and "Button 2" inputs are discrepant without the function entering an error state, it is unchangeable and is set to 500ms. Discrepancy time is counted during the engagement sequence ("Engage Sequence wait for Btn1" and "Engage Sequence wait for Btn2") and is reset in "Monitor Btn1 and Btn2" state.

The principles of design selection detailed in EN ISO13851 should be considered when using this motion safety function. The requirements to be considered are detailed in Section 5. The topics are identified below for information.

- Use of both hands (simultaneous actuation)
- Relationship between input signals and output signal
- Cessation of the output signal
- Prevention of accidental operation
- Prevention of defeat
- Re-initiation of the output signal
- Synchronous actuation

**Figure 8-35 Diagrammatic representation of the Safe Two Handed Control Type 3 function**

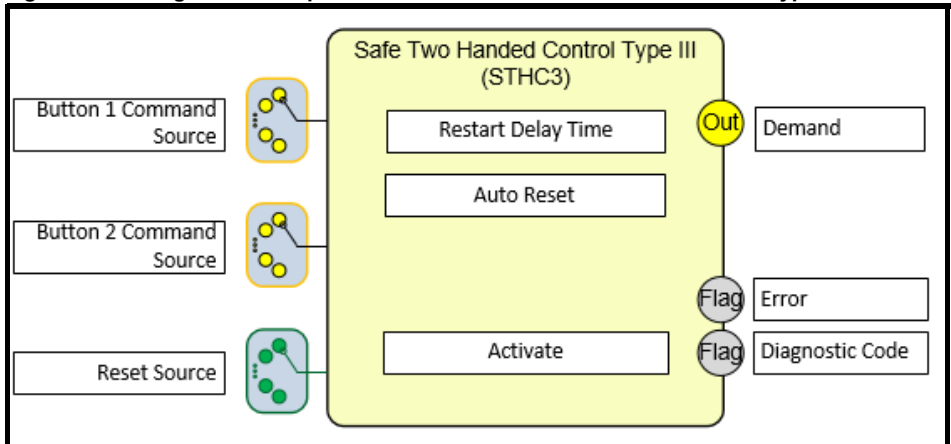

**Standards:**

EN 574: 1996

Clause 4, Table 1, Type III A; B; C.

5.1 Use of both hands / simultaneous actuation.

5.2 Relationship between output signal and input signals.

5.3 Completion of the output signal.

5.6 Reinitiation of the output signal.

5.7 Synchronous actuation.

6.2 Use of DIN EN 954-1 category 1.

6.3 Use of DIN EN 954-1 category 3. (Can only be realized by NO and NC switches together with antivalent processing)

6.4 Use of DIN EN 954-1 category 4. (Can only be realized by NO and NC switches together with antivalent processing)

ISO 12100-2: 2003

4.11.4: Restart following power failure/spontaneous restart

#### Number of Instances: 1

Name	Description
Button 1 Command Source	Value that will provide the Button 1 input. 0.000: Default (Illegal will cause a configuration error, this must be set by the user) Numeric ID: for a valid Output Connector from another block <u>Value of Source Selected</u> TRUE: Button 1 actuated FALSE: Button 1 released
Button 2 Command Source	Value that will provide the Button 2 input. 0.000: Default (Illegal will cause a configuration error, this must be set by the user) Numeric ID: for a valid Output Connector from another block <u>Value of Source Selected</u> TRUE: Button 2 actuated FALSE: Button 2 released
Demand	Outputs the safety related response of the function FALSE: Demand for safety related response, request for safe state. TRUE: No demand for safety related response, request for operational state.
Reset Source	Value that will provide the reset source, typically it will be System Reset but may be connected to any input to control the Reset. 0.001: Disabled, the Auto Reset attribute must be set to on. 0.002: Default, indicating that the function reset should share the System Reset input Numeric ID: From a Non-Safe Boolean Input (BIS) or from a SAFEBOOL if it is also connected to another Safe Output. <u>Value of Source Selected</u> Rising Edge (a change from FALSE to TRUE): The function will be reset if the error condition is no longer present Falling edge or unchanging TRUE or FALSE: No effect
Restart Delay Time	The minimum time between the function power-up, completed release sequence (both buttons returning FALSE) or clearing an error to entering "Operational" state and allowing reactivation of the "Demand" Time in ms (can be disabled by setting to 0)
Auto Reset	Reset behaviour after the System Start OFF: No special reset behaviour (reset signal is always required to leave the error state) ON: No reset is required to exit error state (automatic reset will be applied) A risk assessment on the system must take place and justification provided in the system documentation before this feature is used.
Error	Indicates that the function has detected an error condition TRUE: Error, check Diagnostic Code for details FALSE: No Error
Diagnostic Code	Diagnostic Fault Code, visible in Connect in Test Mode (see separate table)

Name	Description
Activate	This parameter is used to activate the function. Connect will set this value to TRUE when an MSF is selected. TRUE: function will be executed FALSE: function is deactivated

Figure 8-36 State Machine

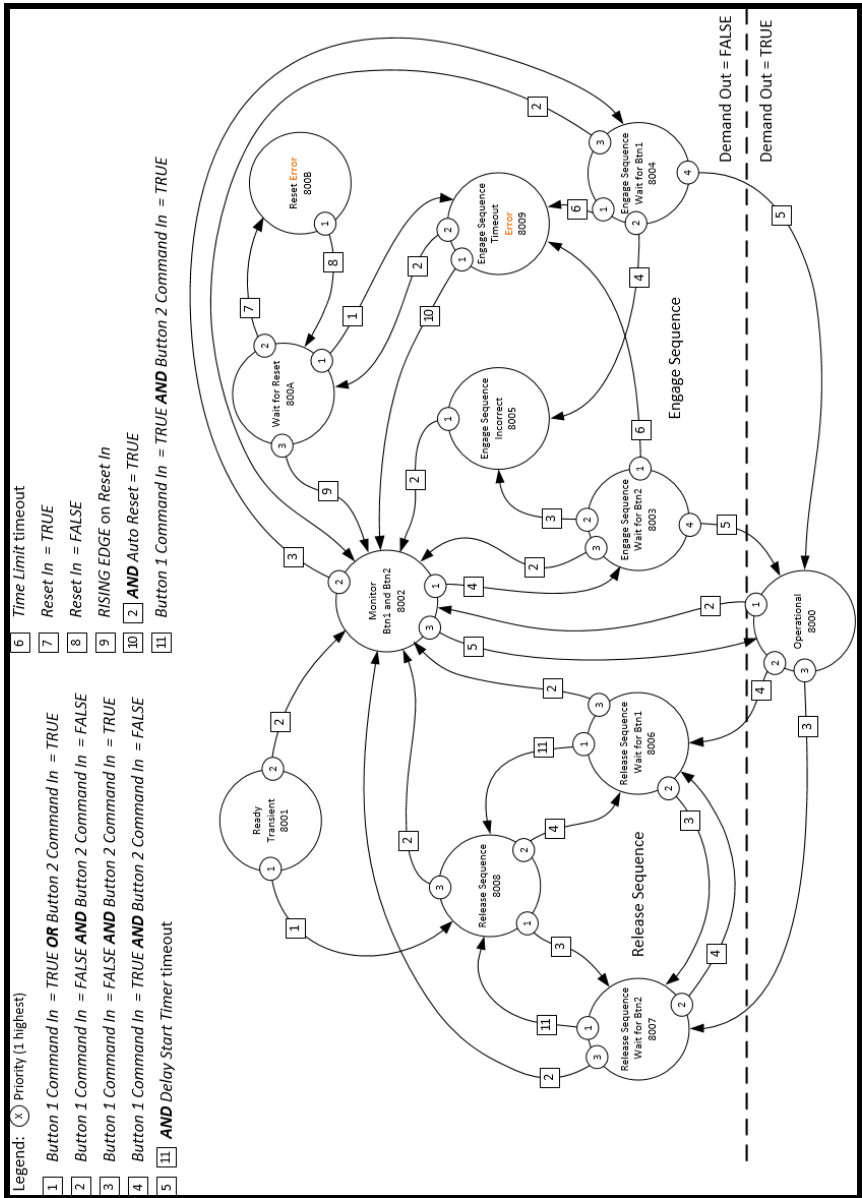

Information
Introduction
Technical Safety Features
Installation
Connect Configuration Tool Introduction
Start Up
Validation
<b>Motion Safety Function Details</b>
Diagnostics and Maintenance
Key Safety Data
Version Control (Amendments)

Figure 8-37 Auto Reset ON

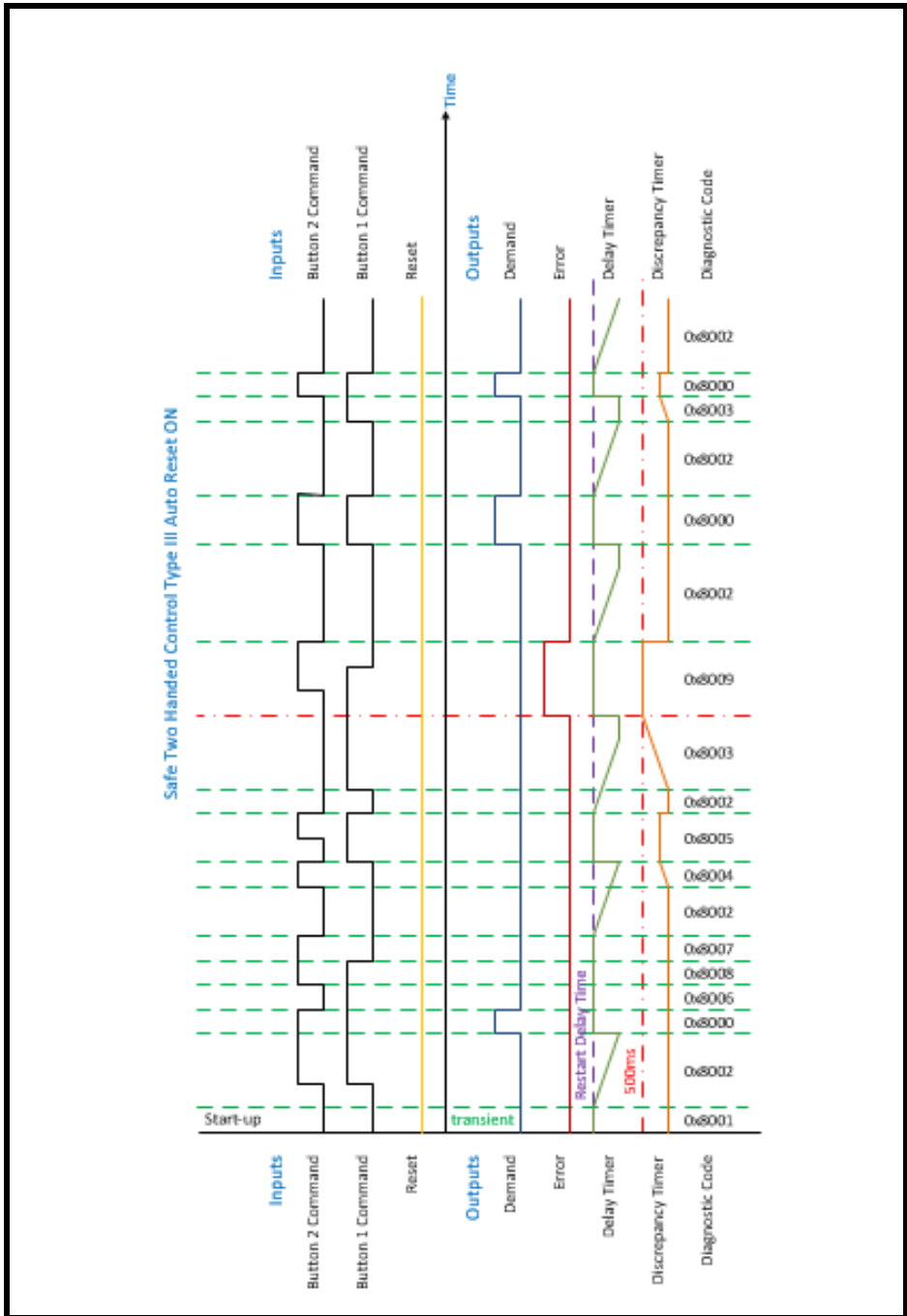
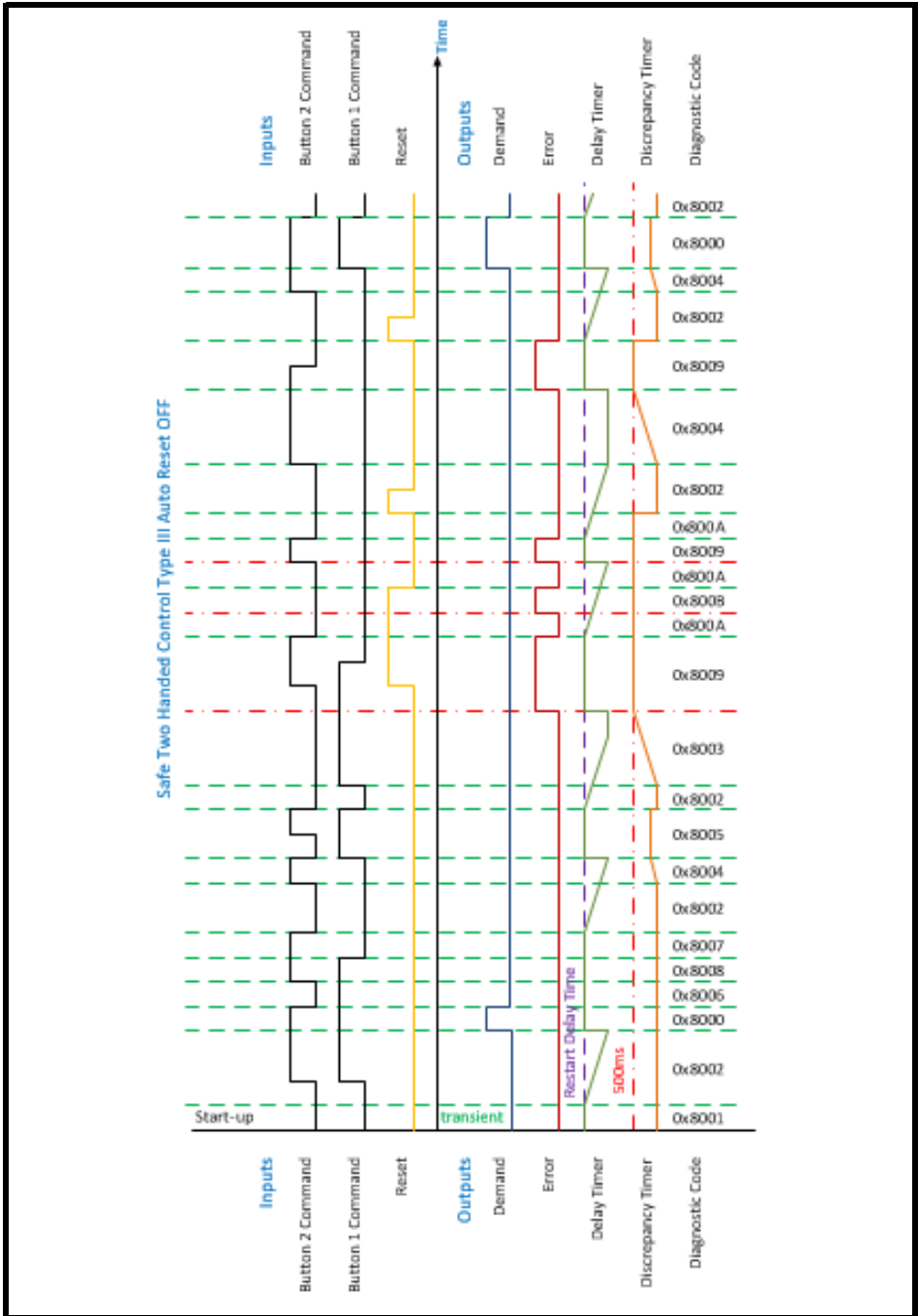

Figure 8-38 Auto Reset OFF



Information
Introduction
Technical Safety Features
Installation
Connect Configuration Tool Introduction
Start Up
Validation
<b>Motion Safety Function Details</b>
Diagnostics and Maintenance
Key Safety Data
Version Control (Amendments)

## DIAGNOSTIC ERRORS – Information for the User

Code	State	Description
0x8009	Engage Sequence Timeout	<p>Only one of the button signals was TRUE while the other was FALSE for more than 500 ms. Both Button inputs need to be FALSE to leave this error state. When the error cause is cleared and "Auto Reset" is ON the function will enter "Monitor Btn1 and Btn2", if "Auto Reset" is OFF the function will enter "Wait for Reset" state and a rising edge signal will be needed on "Reset" input to enter the "Monitor Btn1 and Btn2" state.</p> <p>In this state: "Demand" = FALSE, "Error" = TRUE, "Discrepancy Timer" stays the same, "Delay Timer" is reset to "Restart Delay Time"</p>
0x800B	Reset Error	<p>Reset signal was TRUE while the function entered "Wait for Reset" state. Reset signal needs to be FALSE to leave this error state.</p> <p>In this state: "Demand" = FALSE, "Error" = TRUE, "Discrepancy Timer" stays the same, "Delay Timer" is decremented until it reaches zero</p>
0x8000	Operational	<p>In this state safe output is set TRUE. To enter this state both button signals must be set to TRUE at the same time or within 500 ms of each other and value of "Delay Timer" needs to be equal to zero.</p> <p>In this state: "Demand" = TRUE, "Error" = FALSE, "Discrepancy Timer" is reset to zero, "Delay Timer" is reset to "Restart Delay Time"</p>
0x8001	Ready	<p>This is a transient state on power up.</p> <p>In this state: "Demand" = FALSE, "Error" = FALSE, "Discrepancy Timer" is zero, "Delay Timer" is set to "Restart Delay Time"</p>
0x8002	Monitor Btn1 and Btn2	<p>Idle state, monitoring "Button 1" and "Button 2" inputs.</p> <p>Note that if both Button inputs are set to TRUE at the same time the function will wait in this state until "Delay Timer" reaches zero. In such case the function will transition to "Operational" state when the countdown ends and both buttons are still pressed.</p> <p>In this state: "Demand" = FALSE, "Error" = FALSE, "Discrepancy Timer" is reset to zero, "Delay Timer" is decremented until it reaches zero</p>
0x8003	Engage Sequence Wait for Btn2	<p>"Button 1" is being pressed alone or both Button inputs are TRUE, but "Button 1" was pressed first and "Delay Timer" didn't reach zero yet</p> <p>Note that if both Button inputs are TRUE the function will wait in this state until "Delay Timer" reaches zero. In such case the function will transition to "Operational" state when the countdown ends and both buttons are still pressed. "Discrepancy Timer" is not running when both Button inputs are TRUE.</p> <p>In this state: "Demand" = FALSE, "Error" = FALSE, "Discrepancy Timer" is incremented if Button inputs are not equal, "Delay Timer" is decremented until it reaches zero</p>
0x8004	Engage Sequence Wait for Btn1	<p>"Button 2" is being pressed alone or both Button inputs are TRUE, but "Button 2" was pressed first and "Delay Timer" didn't reach zero yet</p> <p>Note that if both Button inputs are TRUE the function will wait in this state until "Delay Timer" reaches zero. In such case the function will transition to "Operational" state when the countdown ends and both buttons are still pressed. "Discrepancy Timer" is not running if both Button inputs are TRUE.</p> <p>In this state: "Demand" = FALSE, "Error" = FALSE, "Discrepancy Timer" is incremented if Button inputs are not equal, "Delay Timer" is decremented until it reaches zero</p>
0x8005	Engage Sequence Incorrect	<p>Buttons need to be pressed at the same time or one after another within allowed discrepancy time (500 ms). This state occurs when "Button 1" input was set TRUE and then at the same moment "Button 2" was set TRUE and "Button 1" set FALSE or the when "Button 2" input was set TRUE and then at the same moment "Button 1" was set TRUE and "Button 2" set FALSE. Both Button inputs need to be set FALSE to leave this state.</p> <p>In this state: "Demand" = FALSE, "Error" = FALSE, "Discrepancy Timer" stays the same, "Delay Timer" is reset to "Restart Delay Time"</p>

DIAGNOSTIC ERRORS – Information for the User		
Code	State	Description
0x8006	Release Sequence Wait for Btn1	This state occurs after "Operational" state when "Button 2" input is set FALSE, but "Button 1" input is still TRUE. Note that it is possible to "jump" between this state, "Release Sequence Wait for Btn2" state and "Release Sequence" state as long as at least one Button input is TRUE. To leave this Release Sequence and restart the function both Button inputs need to be FALSE at the same time. In this state: "Demand" = FALSE, "Error" = FALSE, "Discrepancy Timer" stays the same, "Delay Timer" is reset to "Restart Delay Time"
0x8007	Release Sequence Wait for Btn2	This state occurs after "Operational" state when "Button 1" input is set FALSE, and "Button 2" input is still TRUE. Note that it is possible to "jump" between this state, "Release Sequence Wait for Btn1" state and "Release Sequence" state as long as at least one Button input is TRUE. To leave this Release Sequence and restart the function both Button inputs need to be FALSE at the same time. In this state: "Demand" = FALSE, "Error" = FALSE, "Discrepancy Timer" stays the same, "Delay Timer" is reset to "Restart Delay Time"
0x8008	Release Sequence	This state occurs after "Release Sequence Wait for Btn1" or "Release Sequence Wait for Btn2" state when both Button inputs are set TRUE. It can also occur when one or both of the Button inputs was TRUE during the start-up. Note that it is possible to "jump" between this state, "Release Sequence Wait for Btn1" state and "Release Sequence Wait for Btn2" state as long as at least one Button input is TRUE. To leave this Release Sequence and restart the function both Button inputs need to be FALSE at the same time. In this state: "Demand" = FALSE, "Error" = FALSE, "Discrepancy Timer" stays the same, "Delay Timer" is reset to "Restart Delay Time"
0x800A	Wait for Reset	If "Auto Reset" is OFF, this state occurs after an error state. It indicates that cause of the error is no longer present, and the function can be reset. To leave this state a rising edge signal needs to occur on "Reset input" while both Button inputs are FALSE. If any Button input turns TRUE, the function will re-enter "Engage Sequence Timeout". "Reset Error" will be reported if "Reset" input is already TRUE when the function enters "Wait for Reset". In this state: "Demand" = FALSE, "Error" = FALSE, "Discrepancy Timer" stays the same, "Delay Timer" is decremented until it reaches 0

Information

Introduction

Technical Safety Features

Installation

Connect Configuration Tool Introduction

Start Up

Validation

Motion Safety Function Details

Diagnostics and Maintenance

Key Safety Data

Version Control (Amendments)

## 8.11 Safe Operating Stop, SOS

This function when the Command Source is FALSE, monitors the speed of the axis and sets its output TRUE if the axis speed is below the zero-speed threshold and (optionally) if the axis is not creeping, otherwise it is set to FALSE.

**When the error state is entered, by default in the configuration an alarm will be raised, and all the MiS2x0 Safety Module Safe Outputs will be set to SAFE. If this behaviour is not required by the user then they can disable the alarm generation using the Generate MSF Alarm parameter.**

Figure 8-39 Diagrammatic representation of the Safe Operating Stop function

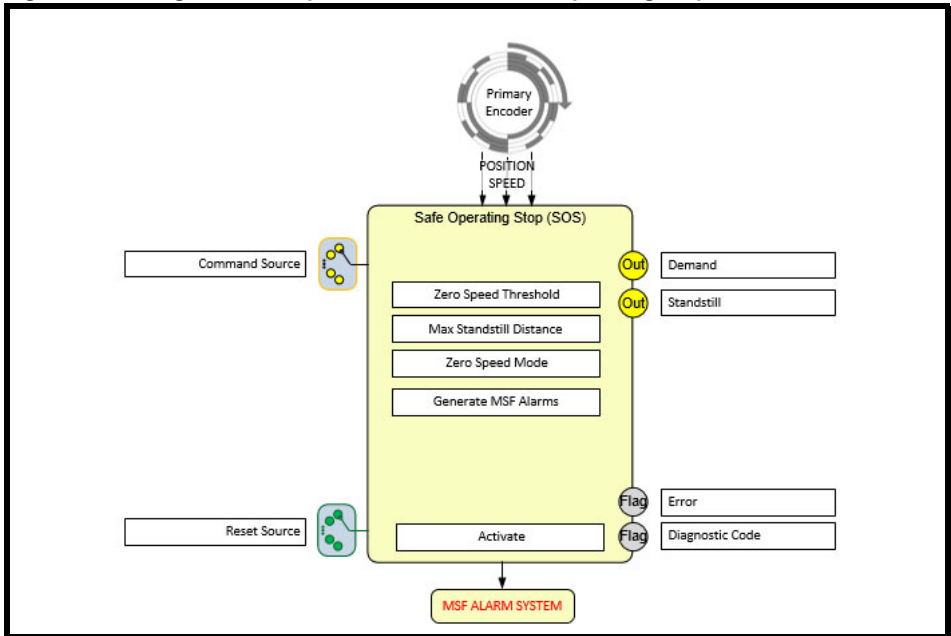

### Standards:

IEC 61800-5-2:2017

Section 4.2.3.1 The SOS function prevents the motor from deviating more than a defined amount from the stopped position. The PDS(SR) provides energy to the motor to enable it to resist external forces.

### NOTE

This description of an operational stop function is based on implementation by means of a PDS(SR) without external (for example mechanical) brakes.

PLC Open

5.2.2.1 Safe Operating Stop (SOS)

Ensures that the motor remains stopped by resisting external forces.

**Number of Instances:** 4

However, one is reserved for use within Safe Stop 2

Name	Description
Command Source	Value which will request safe operating stop monitoring. 0.000: Default (Illegal will cause a configuration error, this must be set by the user) Numeric ID: for a valid Output Connector from another block <u>Value of Source Selected</u> TRUE: Function is Not monitoring zero speed. FALSE: If there is no error, Function is monitoring zero speed.
Demand	Outputs the safety related response of the function. TRUE: The function is initialized and has detected no errors. FALSE: The function is not initialized OR has detected an error OR is waiting for a reset after an error has cleared.
Standstill	Indicates that the axis is being held at zero speed and there is no error. This can be left unused TRUE: When the Command Source is FALSE, and the axis is stopped and there is no error. FALSE: Any other condition.
Reset Source	Value that will provide the reset source, typically it will be System Reset but may be connected to any input to control the Reset. 0.002: Default, indicating that the function reset should share the System Reset input Numeric ID: From a Non-Safe Boolean Input (BIS) or from a SAFEBOOL if it is also connected to another Safe Output. <u>Value of Source Selected</u> Rising Edge (a change from FALSE to TRUE): The function will be reset if the error condition is no longer present Falling edge or unchanging TRUE or FALSE: No effect
Zero Speed Threshold	The speed threshold below which the machine is regarded as stationary, specified in the number of encoder counts per second. Default value = 0, Max: 4294967295 counts per second.
Max Standstill Distance (POSITION MODE ONLY)	Maximum positive or negative distance from the position read when the function is commanded to monitor. If the distance is exceeded the Demand is set FALSE. All movements within the specified distance relative to the position read when the function is commanded will result in the function output, Standstill Out = TRUE. The Max Standstill Distance is specified as number of encoder counts. Default value = 0, Max: 4294967295 counts.
Zero Speed Mode	Selects the speed mode for the function. In speed mode when Command Source goes FALSE the axis is monitored for zero speed. In position mode when Command Source goes FALSE the axis is monitored for both zero speed and standstill. Speed (0): Monitor for zero speed. Position (1): Monitor the Standstill position.
Generate MSF Alarm	Determines whether an alarm is raised when an error is detected which triggers all Safe Outputs to go Safe TRUE: Default, Alarm Raised and all safe outputs go SAFE FALSE: No alarm generated demand output can be chained to another mitigating action
Error	Indicates that the function has detected an error condition. TRUE: Error, check "Diagnostic Code" for details. FALSE: No Error.
Diagnostic Code	Diagnostic Fault Code, visible in Connect in Test Mode (see separate table)
Activate	This parameter is used to activate the function. Connect will set this value to true when an MSF is selected. TRUE: function will be executed. FALSE: function is deactivated.

Information
Introduction
Technical Safety Features
Installation
Connect Configuration Tool Introduction
Start Up
Validation
<b>Motion Safety Function Details</b>
Diagnoses and Maintenance
Key Safety Data
Version Control (Amendments)

Figure 8-40 State Machine

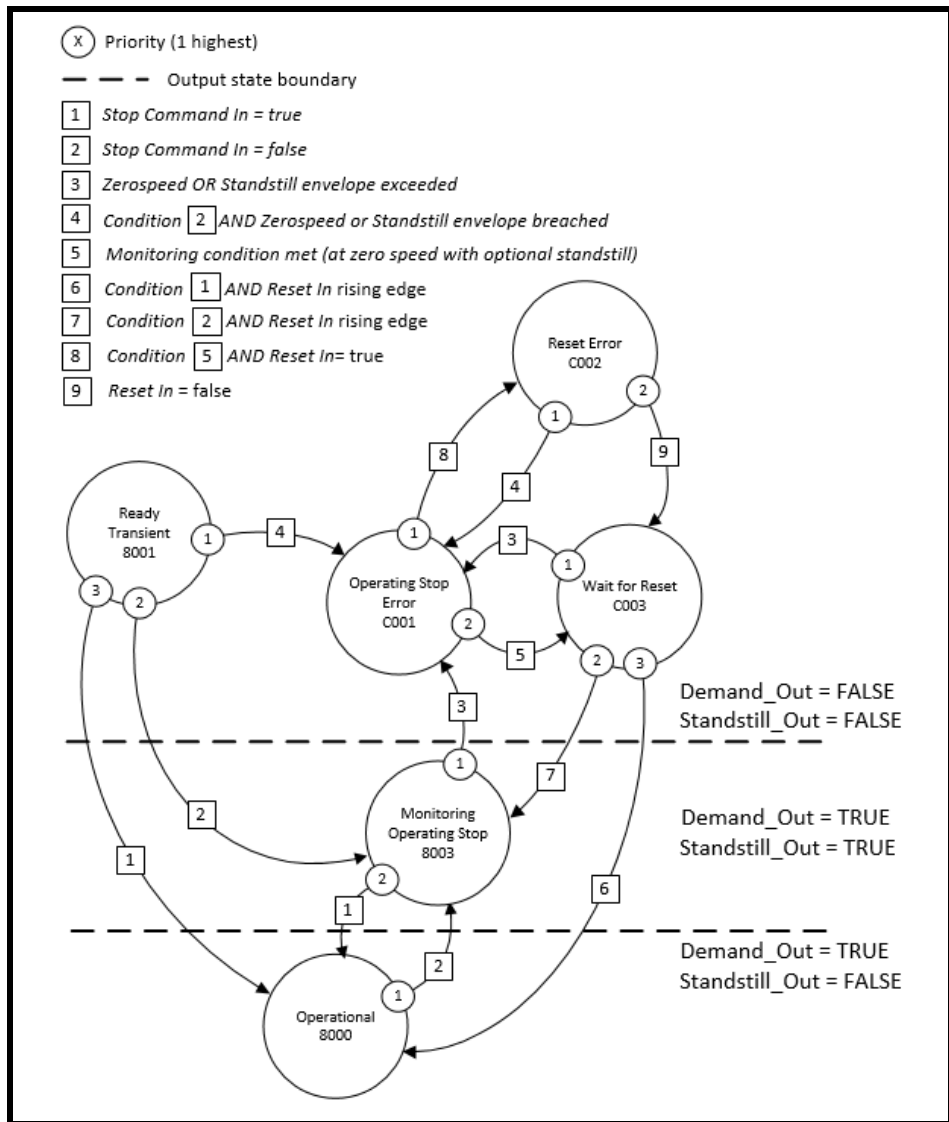
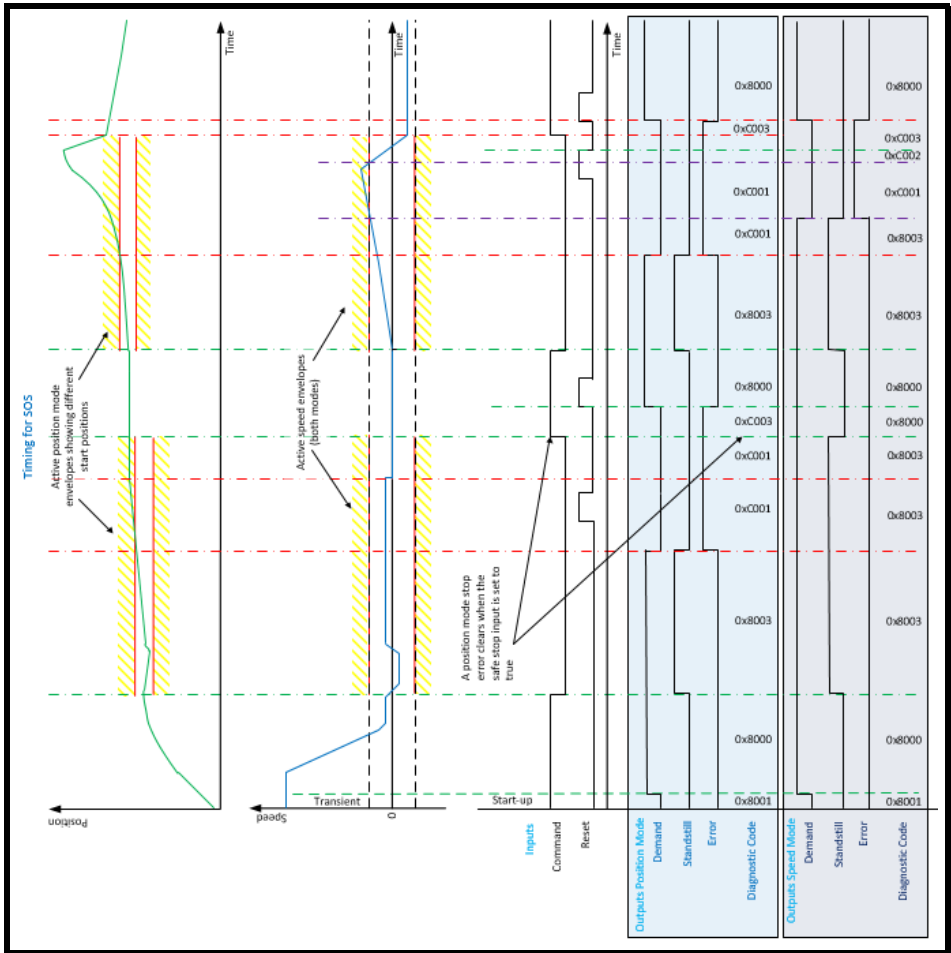

Figure 8-41 Timing Diagram showing the difference between speed and position mode



ERRORS THAT CAN TRIGGER ALARMS - ALL SAFE OUTPUTS GO SAFE		
Code	State	Description
0xC001	Speed Error	In either mode the detected speed is greater than the speed specified in Zero Speed Threshold or excessive creep has been detected in position mode. In this state: "Demand" = FALSE, "Standstill" = FALSE
0xC002	Reset Error	The fault has cleared, and the system requires a Reset to restart, however the "Reset Source" is True hence a rising edge cannot be generated until the reset returns to the False. In this state: "Demand" = FALSE, "Standstill" = FALSE
0xC003	Wait for Reset	Occurs after an error state once the error condition has cleared, a rising edge on the error input is required to leave the state. In this state: "Demand" = FALSE, "Standstill" = FALSE

DIAGNOSTIC ERRORS - Information for the User

Information	Introduction	Technical Safety Features	Installation	Connect Configuration Tool Introduction	Start Up	Validation	Motion Safety Function Details	Diagnostics and Maintenance	Key Safety Data	Version Control (Amendments)
-------------	--------------	---------------------------	--------------	---	----------	------------	--------------------------------	-----------------------------	-----------------	------------------------------

ERRORS THAT CAN TRIGGER ALARMS - ALL SAFE OUTPUTS GO SAFE		
Code	State	Description
0x8000	Operational	Following a transition from the Wait For Reset, or Ready, Transient states the function will wait for the "Command Source" = TRUE. In this state: "Demand" = TRUE, "Standstill" = FALSE
0x8001	Ready - Transient	This is a transient state on power up. In this state: "Demand" = FALSE, "Standstill" = FALSE
0x8003	Monitoring Operating Stop	In this state a demand for SOS is present and the SOS is operating correctly with the Zero Speed Threshold and the Max Standstill Distance not exceeded. Command Source = FALSE. In this state: "Demand" = TRUE, "Standstill" = TRUE

## 8.12 Safely Limited Acceleration, SLA

This function is to monitor the acceleration and check that it is not exceeding a given rate limit. An instance is given one limit value and can be set to monitor one, two or all four quadrants. If the acceleration in a monitored quadrant(s) exceeds the limit value, the Demand is set FALSE.

### Quadrant detection

A dead band equal to 1 % of the limit value is applied to the quadrant detection algorithm. The function will not detect a quadrant if measured acceleration is smaller than 1 %. If the acceleration is above the 1 % dead band and system is in monitored quadrant Safety Active output is set TRUE.

### Acceleration calculation

The maximum acceleration values will typically be large numbers as they are calculated from the encoder count and is expressed in encoder counts per second squared. MiS2x0 calculates acceleration each 1 ms. When speed averaging is not used acceleration, is calculated over 1 ms time window using raw speed reading. When speed averaging is used, acceleration is calculated from filtered speed over time window equal to Speed Averaging Sample Time.

$$acc = \frac{v_{t_2} - v_{t_1}}{dt} \text{ where:}$$

$dt$  - is acceleration time window ( $dt = t_2 - t_1$ )

$t_2$  - is current sample time

$t_1$  - is past sample time

$v_{t_n}$  - is speed sample at time  $t_{11}$

### Latency

The time between speed samples varies in sympathy with the configured Speed Averaging Sample Time filter (See section 8.1) i.e. when a speed filter of four is selected, the two speeds samples 4 ms apart are used to determine the acceleration. This adds additional latency (Speed latency + Acceleration latency) to the monitored Acceleration reading. Calculating acceleration using averaged speed over time window equal to averaged sample count doubles the latency.

Speed Averaging Sample Time	Max Speed Response Time	Acceleration Time Window	Max Acceleration Response Time
1 ms	1 ms	1 ms	2 ms
4 ms	4 ms	4 ms	8 ms
50 ms	50 ms	50 ms	100 ms
100 ms	100 ms	100 ms	200 ms

### Performance Considerations

The SLA function is reliant on the performance of the system attached to determine the true acceleration of the machine. When trying to detect low accelerations the user must consider the encoder, and the machine performance in particular the encoder noise, quantisation noise, non-linearities and normal machine speed fluctuations (typically caused by control loop performance). All of these will contribute to the overall acceleration calculated by the MiS2x0 hence introducing a fluctuation in the calculated acceleration. This needs to be considered when setting the acceleration limit. The user may consider the use of speed filtering and longer time windows at the expense of response time to reduce these effects. The user must be aware that when short periods of acceleration are being monitored the filter must be made shorter than that period to ensure the true value of acceleration is acquired.

The encoder values reported to the MiS2x0 when processed to produce acceleration values must be sufficient in magnitude to minimise the effects indicated above and to get the best performance in terms of acceleration tolerance.

### Units

Acceleration ramps in the drive are expressed in s/1000 rpm (second to 1000 rpm) while acceleration limit in MiS2x0 is set in cps<sup>2</sup> (counts per second squared).

Conversion Table	
$\frac{s}{1000rpm}$ to cps <sup>2</sup>	cps <sup>2</sup> to $\frac{s}{1000rpm}$
$Acc[cps^2] = \frac{1000}{60 * Ramp[\frac{s}{1000rpm}] * EncLines}$	$Ramp[\frac{s}{1000rpm}] = \frac{1000}{60 * Acc[cps^2]} * \frac{1}{EncLines}$
<p>Where:</p> <p>Acc[cps<sup>2</sup>] – acceleration in encoder counts per second squared</p> <p>Ramp [<math>\frac{s}{1000rpm}</math>] – acceleration ramp in seconds per 1000rpm</p> <p>EncLines – Encoder Lines per revolution</p>	

### NOTE

When using an AB or Sin Cos Encoder, users must respect the maximum frequency that the MiS2x0 can accommodate - 350 KHz

Figure 8-42 Visual Representation of the 4 Quadrants

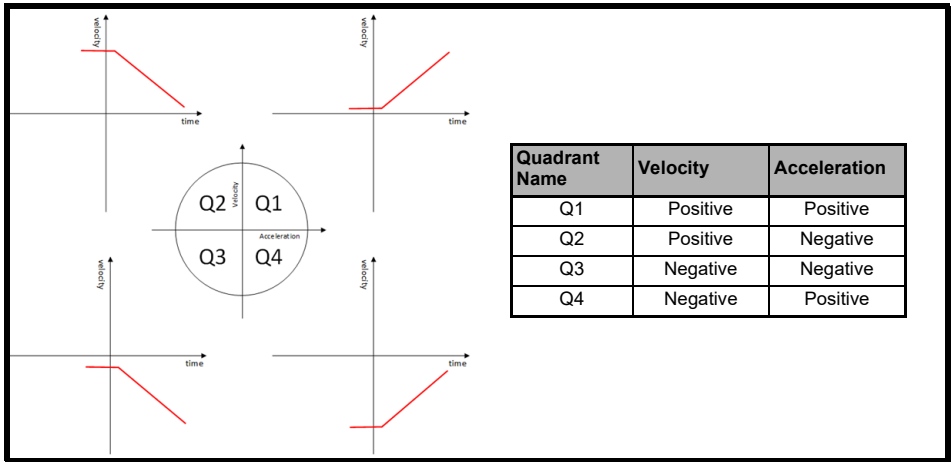

**Errors and Reset:**

If an error occurs the function will set "Demand" to FALSE and will remain in this state until the source of the error clears. The function must then be reset by means of a rising edge applied to the reset input; auto reset is not permitted for this function.

**When the error state is entered, by default in the configuration an alarm will be raised, and all the MiS2x0 Safety Module Safe Outputs will be set to SAFE. If this behaviour is not required by the user then they can disable the alarm generation using the Generate MSF Alarm parameter.**

Figure 8-43 Diagrammatic representation of the Safely Limited Acceleration function

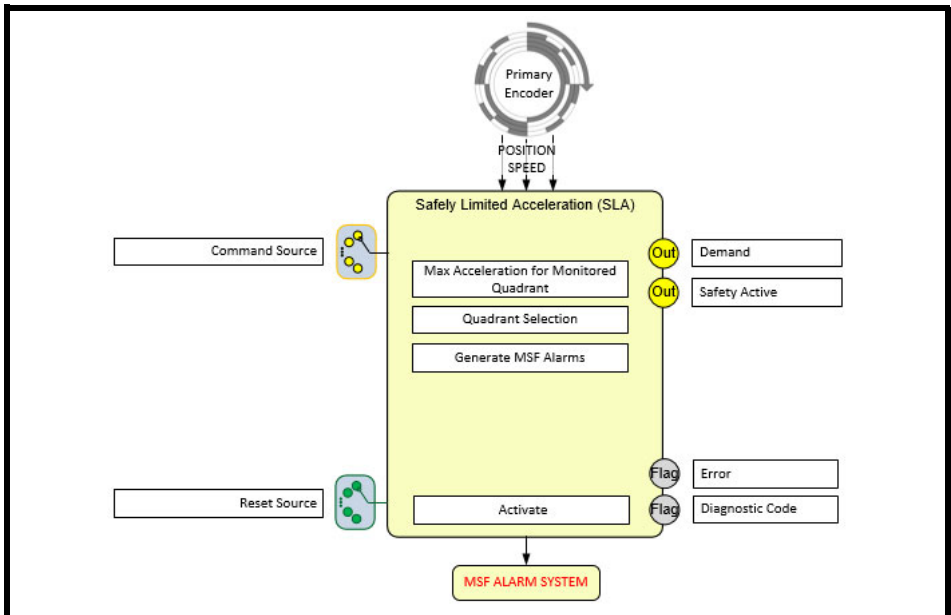

**Standards:**

EN 61800-5-2:2017

## 4.2.3.14 Safe Speed Monitor (SLA)

The SLA function prevents the motor from exceeding the specified acceleration limit.

**Number of Instances:** 4

Name	Description
Command Source	Value for the quadrant monitoring control signal which will request acceleration monitoring for that quadrant; alternatively monitoring can be set to always on or always off. 0.000: Default (Illegal will cause a configuration error, this must be set by the user) Numeric ID: for a valid Output Connector from another block <u>Value of Source Selected</u> TRUE: Quadrant acceleration monitoring off FALSE: If there is no error, quadrant acceleration monitoring on
Demand	Outputs the safety related response of the function. TRUE: The function is initialized AND the function has detected no errors AND Command is FALSE. FALSE: The function is not initialized OR has detected an error OR the Command is TRUE OR is waiting for a reset after an error has cleared.
Safety Active	Provides a safe signal to indicate if any monitoring is active and the monitored axis passes the active envelope testing. If the function is activated its use is optional and it may be left disconnected. TRUE: The function is initialised AND is monitoring a threshold AND there are no errors. FALSE: The function is not initialized, OR has detected an error OR is below the threshold OR is not monitoring
Reset Source	Value that will provide the reset source, typically it will be System Reset but may be connected to any input to control the Reset. 0.001: Disabled, the Auto Reset attribute must be set to on. 0.002: Default, indicating that the function reset should share the System Reset input (Menu 6) Numeric ID: From a Non-Safe Boolean Input (BIS) or from a SAFEBOOL if it is also connected to another Safe Output. <u>Value of Source Selected</u> Rising Edge (a change from FALSE to TRUE): The function will be reset if the error condition is no longer present Falling edge or unchanging TRUE or FALSE: No effect
Max Acceleration for Monitored Quadrant	The maximum acceleration in counts s <sup>-2</sup> (counts per second squared) for the quadrant if monitoring is active.
Quadrant Selection	Determines which quadrant or quadrants the monitoring is carried out in 0: All Quadrants 1: Quadrant 1 2: Quadrant 2 3: Quadrant 3 4: Quadrant 4 5: Quadrants 1 and 3 6: Quadrants 2 and 4
Generate MSF Alarm	Determines whether an alarm is raised when an error is detected which triggers all Safe Outputs to go Safe TRUE: Default, Alarm Raised and all safe outputs go SAFE FALSE: No alarm generated; demand output can be chained to another mitigating action
Error	Indicates that the function has detected an error condition. TRUE: Error, check "Diagnostic Code" for details. FALSE: No Error.
Diagnostic Code	Diagnostic Fault Code, visible in Connect in Test Mode (see separate table)
Activate	This parameter is used to activate the function. Connect will set this value to TRUE when an MSF is selected. TRUE: function will be executed FALSE: function is deactivated.

Information
Introduction
Technical Safety Features
Installation
Connect Configuration Tool Introduction
Start Up
Validation
<b>Motion Safety Function Details</b>
Diagnostics and Maintenance
Key Safety Data
Version Control (Amendments)

Figure 8-44 State Machine

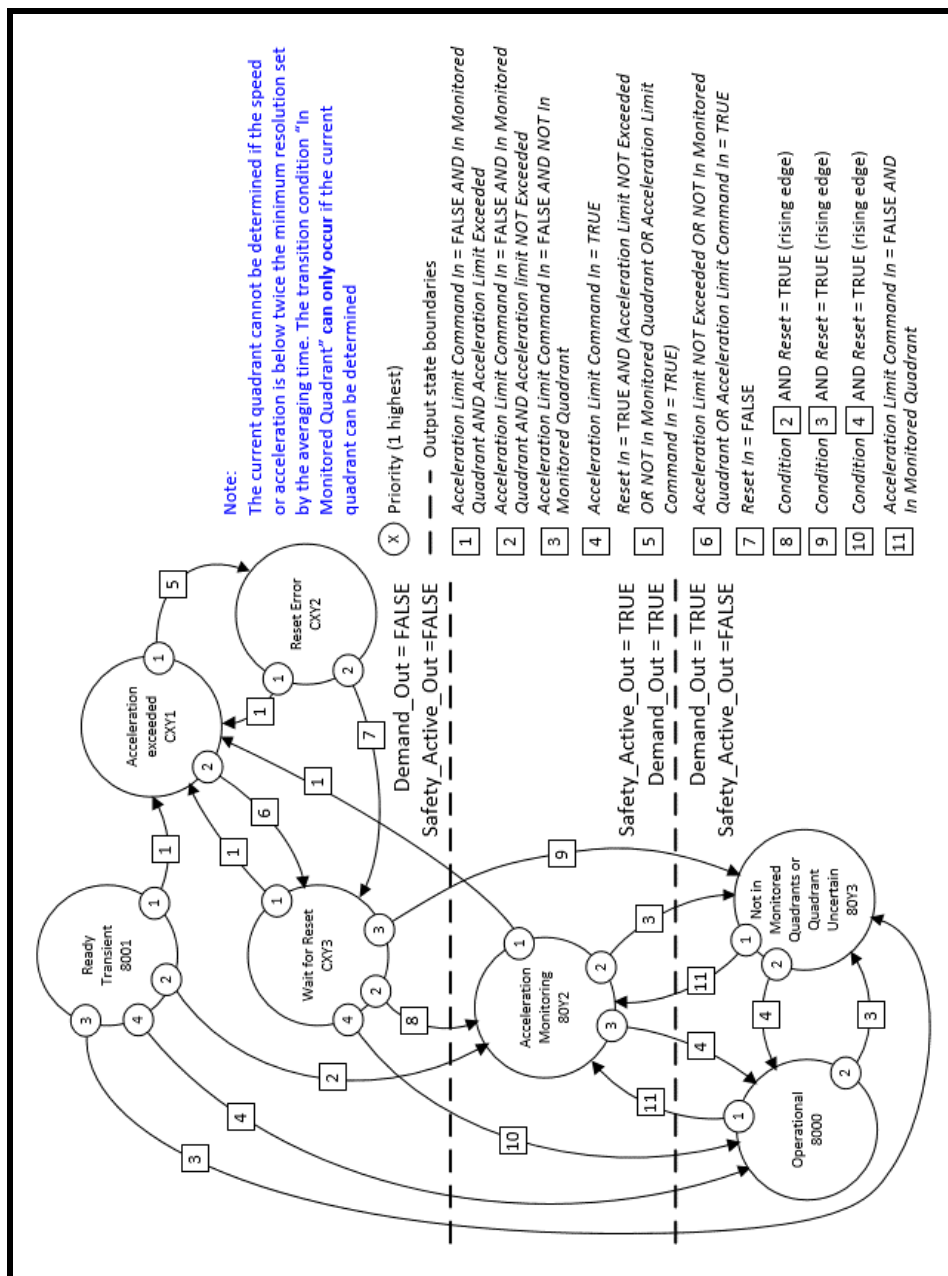

X in the diagnostic code indicates state prior to alarm, Y indicates the current quadrant or in alarm state the quadrant in which the alarm was detected

Figure 8-45 SLA timing diagram

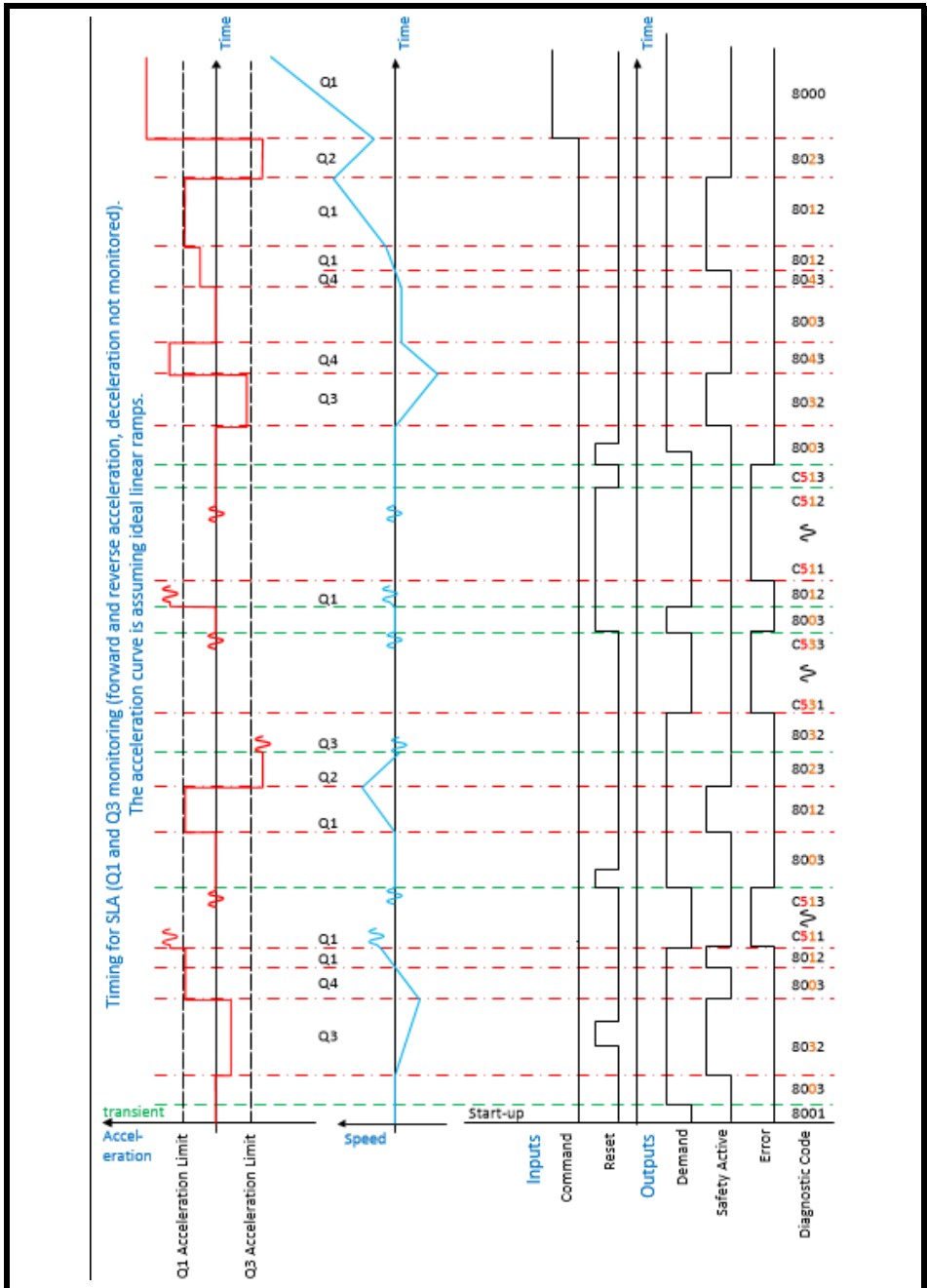

The XY fields in the diagnostic code show the values for this scenario

Information	Introduction	Technical Safety Features	Installation	Connect Configuration Tool Introduction	Start Up	Validation	<b>Motion Safety Function Details</b>	Diagnoses and Maintenance	Key Safety Data	Version Control (Amendments)
-------------	--------------	---------------------------	--------------	---	----------	------------	---------------------------------------	---------------------------	-----------------	------------------------------

**ERRORS THAT CAN TRIGGER ALARMS - ALL SAFE OUTPUTS GO SAFE**

Code	State	Description
CXY1	Acceleration exceeded	Occurs when the axis acceleration exceeds the acceleration limit in monitored quadrant. The X in the code is a 4 bit value that can be used to determine in which state error occurred: 1 – Error started in Ready state, 5 – Error started in Acceleration Monitoring state The Y in the code is a 4 bit value that can be used to determine in which Quadrant the acceleration limit was exceeded (from 1 to 4). In this state: "Demand" = FALSE, "Safety Active" = FALSE, "Error" = TRUE
CXY2	Reset Error	Occurs if the reset signal is high when the CXY1 error clears. In this state: "Demand" = FALSE, "Safety Active" = FALSE, "Error" = TRUE
CXY3	Wait for Reset	Occurs after an error state once the error condition has cleared, a rising edge on the Reset input is required to leave the state. In this state: "Demand" = FALSE, "Safety Active" = FALSE, "Error" = FALSE
<b>DIAGNOSTIC ERRORS - Information for the User</b>		
8000	Operational	Function is not monitoring acceleration and axis may run above the acceleration limit determined by Max Acceleration for Monitored Quadrant attribute even when axis is in monitored quadrant. To enter this state Command input must be TRUE. In this state: "Demand" = TRUE, "Safety Active" = FALSE, "Error" = FALSE
8001	Ready	A transient state that occurs for 1 cycle at start up, allows inputs to be checked before any output re set to TRUE. In this state: "Demand" = FALSE, "Safety Active" = FALSE, "Error" = FALSE
80Y2	Acceleration Monitoring	Axis is in monitored quadrant determined by Quadrant Selection attribute. Function is monitoring the safe acceleration limit and axis acceleration should be below the safe acceleration threshold, as defined by the Max Acceleration for Monitored Quadrant attribute. The Y in the code is a 4 bit value that can be used to determine in which quadrant axis is currently in. To enter this state Command input must be FALSE. In this state: "Demand" = TRUE, "Safety Active" = TRUE, "Error" = FALSE
80Y3	Not in Monitored Quadrants or Quadrant Uncertain	Axis is not in monitored quadrant determined by Quadrant Selection attribute, or the quadrant cannot be determined (acceleration below 1% dead band). The Y in the code is a 4 bit value that can be used to determine in which quadrant axis is currently in (0 if quadrant is uncertain). To enter this state Command input must be FALSE. In this state: "Demand" = TRUE, "Safety Active" = FALSE, "Error" = FALSE

### 8.13 Safe Speed Monitoring, SSM

The purpose of this function is to monitor the speed of the drive and set the output true if the axis speed is below the monitoring speed or false otherwise.

**Figure 8-46 Illustration of output state with axis speed**

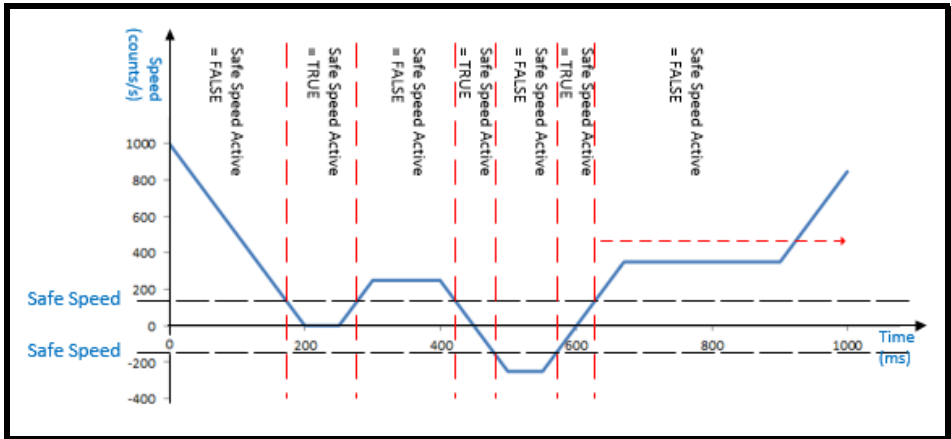

**Figure 8-47 Diagrammatic representation of the Safe Speed Monitoring function**

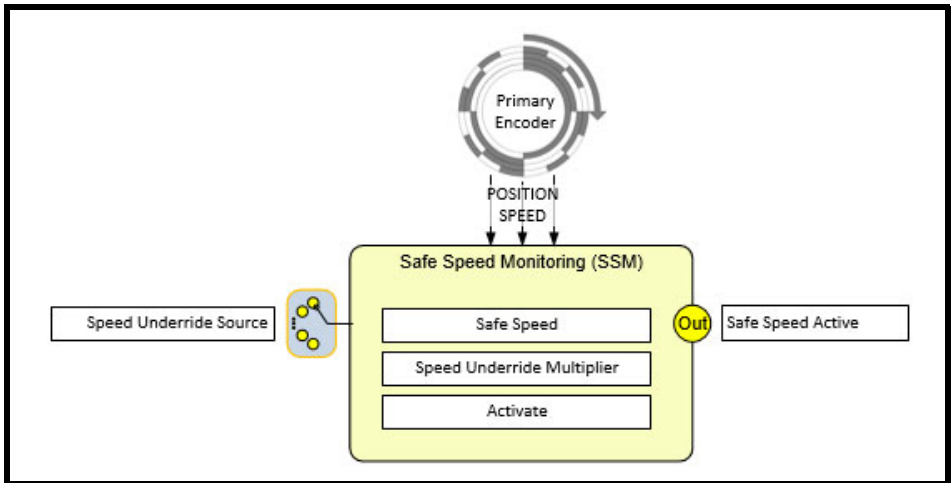

**Standards:**

IEC 61800-5-2: 2017

4.2.3.14 Safely Speed Monitor (SSM)

The SSM function provides a safe output signal to indicate whether the motor speed is below a specified limit.

**Number of Instances:** 4

Name	Description
Safe Speed Active	Outputs the safety related response of the function FALSE: The function is not initialized, OR and the axis speed is above the safe speed value. TRUE: The function is initialized, and the axis speed is below or equal to the safe speed value.
Safe Speed	Speed that the function will use for its speed limit, unless it is under-ridden by the Speed Underride Input and its multiplier, if this is the case then this parameter acts as an upper limit on the Speed Underride Input. Safe speed in encoder counts/s
Speed Underride Multiplier	Works in conjunction with Speed Underride Source, it allows the underride input to be scaled up to match the internal 64 bit speed value. The minimum value is 1. <b>NOTE</b> This feature will typically only be required if the Speed Limit value is greater than 232
Speed Underride Source	Provides a value to reduce the speed limit below the value in the Safe Speed attribute but not increase the speed limit above this value. The value can only be selected from a 32bit Safety Network input. A 32 bit multiplier is provided so that the input can (if necessary) be scaled up to match the internal 64 bit speed value. The selected value <b>MUST</b> be positive. 0.001: Default, disables the Speed Underride Input and the function will use the "Safe Speed" attribute value as the limit. Numeric ID: for a valid SAFEINT output connector
Activate	This parameter is used to activate the function. Connect will set this value to TRUE when an MSF is selected. TRUE: function will be executed FALSE: function is deactivated.

## 8.14 Safe Datum, SDM

The purpose of this function is to provide a datum for position dependent safety functions (e.g. SLP), allowing them to work relative to a known position on the axis.

The function interacts with all activated position dependent safety functions, so that when the axis has been datumed the function behaves in its normal manner, but if the axis is not datumed the function enters "datuming mode" where the function's mitigating output, is forced TRUE and other safety outputs are set to FALSE (as position is unknown). This allows the mitigating outputs of all active safety functions to be "ANDed" together to a single output (typically STO via the STO function or a safe output wired to the drive STO), and so the axis can be moved under power.

A datum occurs when the axis is below the zero-speed threshold and the command input goes high. When this happens, an offset is calculated so that the position used by any activated position dependent safety functions is relative to the datum position set in the Safe Position parameter of this function. The Datum Set flag is also set to TRUE, and both this and the Datum Offset are stored as part of the configuration until the datum position is next invalidated.

### Rotary encoders

The range will typically be asymmetric about the datum.

During the Datuming procedure, detection of a second wrap in either direction will raise a system level alarm.

Once datumed the raw absolute position may wrap once in each direction. Additionally, the adjusted raw position (raw position + Safe position offset) will cause an Alarm to be raised if a wrap in either direction is detected and will cause the datum to be invalidated.

## Linear encoders

The range is limited by physical characteristics and so cannot wrap.

### NOTE

- It is the responsibility of the motion control system to move the axis onto the safe datum sensor and stop, a safe output is provided to signal that a datum is required (this may be connected to a non-safe output). On some machines it may be possible to incorporate this into the normal axis home sequence.
- Suitable safety measures should be in place to deal with the case when a datum is required, and no position fail mitigation output can be provided by the module. A Datum Required safe output is provided that might be used for controlling gates and/or to switch on SLS (Safely Limited Speed) during the process of searching for home.
- AB and SC encoder signals are integrated by a low-level co-processor in the module, producing a cyclic 25 bit position ranging from 0 to 33554431 counts, irrespective of the encoder resolution.
- When a datum is in progress all activated position dependent safety functions will report 0x8FFF as their diagnostic code
- Non-position dependent functions are not affected by SDM



**WARNING**

- If the Go Live input is disabled, then the datuming state may be entered at power up and depending on the configuration the axis could be free to move without position monitoring. A risk assessment must be performed before this input is disabled.
- *In the case of absolute encoders, after an initial Datum SDM will not enabled hence position dependent safety functions are never inhibited. Following any possibility of absolute encoder position change (e.g. a broken coupling, an encoder is replaced, etc.) the encoder position will need to be checked, and if necessary, the encoder position will need to be recommissioned (re datumed).*
- *SDM MUST be used with AB, SC and SSI encoders after each power up if position dependent safety functions are required. These encoders do not provide absolute position hence the actual position of the machine is not known after a power cycle.*
- If power is lost during the configuration save that occurs following a datum, then the entire configuration will also be lost. A configuration download will then be required to recover from the power loss. If there is a risk of frequent unexpected power loss, then a 24 V back up power supply may be used to keep the module electronics active.
- Once the datum has been located by the motion controller the axis **must not be moved** until the Datum Required output goes true.
- If an invalidate datum is initiated (which can only occur at zero speed) the motion controller **must not move the axis** until the Invalidate input is cleared by the module and Datum Required output goes FALSE.
- If the power is lost during a Datum Process, then the whole process needs to be repeated as the previous datum may still be stored.

### Datum after power up

If an absolute encoder is being used and the Datum function is set to datum after power up, or it is the first time the module has been run with an absolute encoder, the datum is invalid and therefore must be set before operation can proceed. If Go Live is enabled, when a rising edge is detected the Demand out will be set true thus signalling that the axis can move. If GoLive is disabled, the Demand out is set true immediately. When the Command is true (Datum Located) and the speed is below the zero-speed threshold the datum offset is calculated and stored in the MiS2x0 internal non-volatile memory and operation of position related functions can begin.

Information

Introduction

Technical Safety Features

Installation

Connect Configuration Tool Introduction

Start Up

Validation

Motion Safety Function Details

Diagnostics and Maintenance

Key Safety Data

Version Control (Amendments)

In the case of a relative encoder, a datum is required at each power up. If Go Live is enabled, when a rising edge is detected the Demand out will be set true thus signalling that the axis can move. If GoLive is disabled, the Demand out is set true immediately. When the Command is true (Datum Located) and the speed is below the zero speed threshold the datum offset is calculated and stored in the MiS2x0 volatile memory (the value will be lost if the power is removed) and operation of position related functions can begin.

**User invalidating the Datum**

The Invalidate Datum input from the Module Menu (section 9.5.3) works in conjunction with the "Go Live Source" input.

The Invalidate Datum input invalidates the current datum clearing both the Datum Set flag and the Datum Offset value. It is only activated when Go Live input is TRUE and the axis speed is zero.

Once invalidate datum has been accepted the Demand output will be set to FALSE until a rising edge is detected on the Go Live input indicating the start of a Datum. When the datum is detected on the command input and the speed is below the zero-speed threshold, the datum offset is calculated, and operation can begin following a reset.

**Encoder fault: Datum recovery**

For absolute encoders on an axis where once commissioned the need for regular re-datuming is unlikely, redatuming following maintenance or encoder failure and replacement will be required. All encoders may have their datum invalidated by the occurrence of an encoder fault (for instance disconnecting the encoder when the module is running).

To re-commission a system after an encoder fault the module must be powered off, the fault condition removed and switched back on. The SDM function will then wait for a rising edge on the Go Live signal followed by the Command input indicating the datum is located and the axis speed is below the Zero Speed Threshold. Normal operation can begin after a reset. Note If an absolute encoder is used and "datum when required" is selected, the datum offset will be stored in the MiS2x0 non volatile memory hence will be available after a power cycle.

The following table shows the interaction of Axis Speed, Go Live and Invalidate Datum Inputs:

Axis Speed	Go Live Source Value	Datum Invalidate Input	Action
Above Zero	Not Used (Disabled)	Falling edge	Reset datum timeout if and only if in Datum Timeout state otherwise no effect
		Rising edge	No effect
At Zero	False	Falling edge	Reset datum timeout if and only if in Datum Timeout state otherwise no effect
		Rising edge	No effect
	True	Falling edge	Reset datum timeout if and only if in Datum Timeout state otherwise no effect
		Rising edge	Clear Datum Offset and set Datum Set and Datum Required to false

**Figure 8-48 Diagrammatic representation of the Safe Datum function**

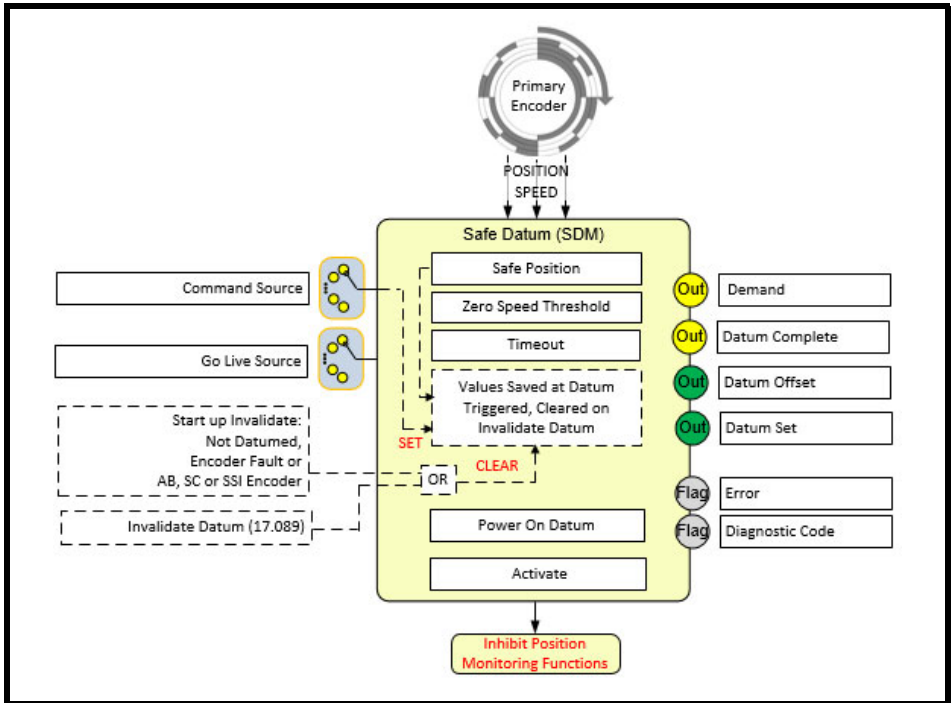

**Standards:**

EN 61800-5-2:2017

**4.2.3.4 Safely-Limited Speed (SLP)**

The SLP function prevents the motor shaft from exceeding the specified position limit(s). SDM function is required to achieve SLP.

**Number of Instances: 1**

Name	Description
Command Source	Provides the trigger input to the MiS2x0 for the machine being in the Safe Datum position, a high (axis must be below the zero speed threshold) on the selected value will cause the Datum Offset Value and Datum Set to be saved and any activated position dependent functions will operate normally again. 0.000: Default (Illegal will cause a configuration error; this must be set by the user if the function is used) Numeric ID: for a valid input, Network or Hardware <u>Value of Source Selected</u> TRUE: At Datum Position FALSE: Not at Datum Position

Information
Introduction
Technical Safety Features
Installation
Connect Configuration Tool Introduction
Start Up
Validation
<b>Motion Safety Function Details</b>
Diagnostics and Maintenance
Key Safety Data
Version Control (Amendments)

Name	Description
Go Live Source	<p>Provides the input to the MiS2x0 to tell it to allow the machine axis to move so as the Datum process can complete. This is an optional input, but the system designer must be made aware that once a new datum is requested, without this additional input, STO will be deactivated (or other mitigation set to TRUE) and the machine may start to move immediately.</p> <p>0.000: Default (Illegal will cause a configuration error)</p> <p>0.001: Disabled, disables the input and the datum process may start immediately</p> <p>Numeric ID: for a valid input, Network or Hardware</p> <p><u>Value of Source Selected</u></p> <p>TRUE (Rising Edge): Datum process starts if waiting for Go Live (see State Machine) otherwise ignored</p> <p>TRUE: Normally does nothing but if entering "Wait for Go Live" state causes an error</p> <p>FALSE: Normally does nothing but if in "Go Live High on Wait Entry" state exits the state</p>
Datum Complete	<p>Outputs whether the system has been datumed or not</p> <p>FALSE: Axis has not been datumed: Position monitoring functions inhibited (their mitigating outputs are held TRUE, other safe outputs FALSE, safe inputs have no effect) Other functions unaffected</p> <p>TRUE: Axis has been datumed: Position Monitoring Functions operate normally (their safe outputs are fully controlled and safe inputs functional)</p>
Safe Position	<p>This unsigned 64-bit value must be set by the user to be the actual Safe Datum Position relative to the axis in encoder counts.</p> <p><b>NOTE</b></p> <p>The Safe Position value MUST be within the range of the encoder used.</p>
Zero Speed Threshold	<p>This 32-bit value defines the speed threshold below which the machine is regarded as stationary, specified in the number of encoder counts per second.</p> <p>Default is 0 and maximum is 4294967295.</p> <p>The Datum offset will not be recorded until the axis is stationary and the Command Source input is TRUE</p>
Timeout	<p>The maximum time in milliseconds that the datum process can run.</p>
Power On Datum	<p>This parameter is used to select if an Absolute Encoder should be datumed on every power on</p> <p>TRUE: Datum every Power On (Default)</p> <p>FALSE: Do Not Datum on Power On</p>
Datum Offset	<p>This 1-bit value contains the current datum status, it can be mapped to a scope output or a non-safe Boolean output or read using Connect</p> <p>FALSE: Datum Offset Position has not been determined (or has been invalidated)</p> <p>TRUE: Datum Offset Position has been stored and position dependent functions can run normally</p>
Error	<p>Indicates that the function has detected an error condition</p> <p>TRUE: Datum Timeout Occurred, check Diagnostic Code for details</p> <p>FALSE: No Error</p>
Diagnostic Code	<p>Diagnostic Fault Code, visible in Connect in Test Mode (see separate table)</p>
Activate	<p>This parameter is used to activate the function. Connect will set this value to TRUE when an MSF is selected.</p> <p>TRUE: function will be executed</p> <p>FALSE: function is deactivated.</p>

**Figure 8-49 State Machine**

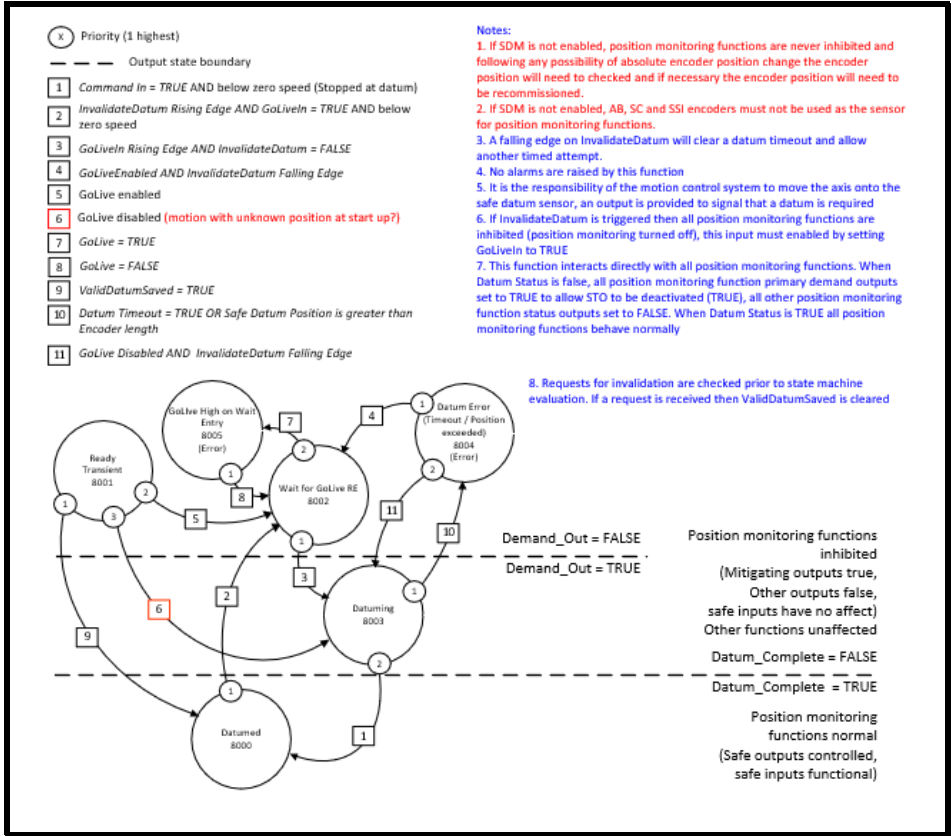

DIAGNOSTIC ERRORS - Information for the User		
Code	State	Description
8000	Datumed	Axis is datumed and position dependent functions run normally
8001	Ready	Start-up transient
8002	Wait for Go Live	Waiting for Rising Edge on Go Live before starting Datum Process
8003	Datuming	Waiting to see Command input Go High at zero speed indicating datum position
8004	Datum Error (Timeout / Position Exceeded)	Datum process timeout OR Safe Position greater than encoder range
8005	Go Live High on Wait Entry	Go Live Input was high on entry to go live state, clear by setting Go Live input to False (does not occur if Go Live input is disabled)

Information
Introduction
Technical Safety Features
Installation
Connect Configuration Tool Introduction
Start Up
Validation
Motion Safety Function Details
Diagnostics and Maintenance
Key Safety Data
Version Control (Amendments)

Figure 8-50 Timing Diagram when Go Live Disabled

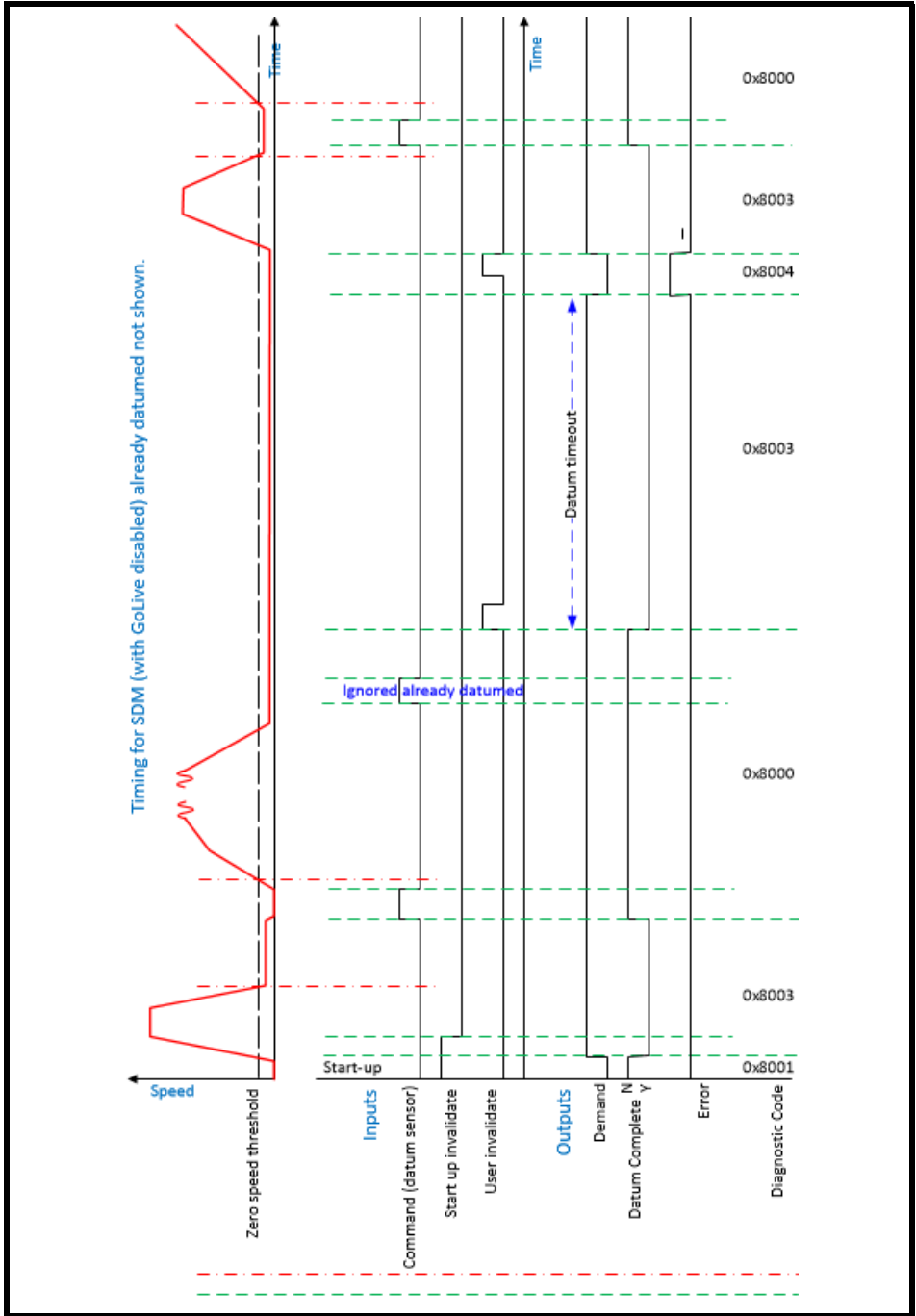
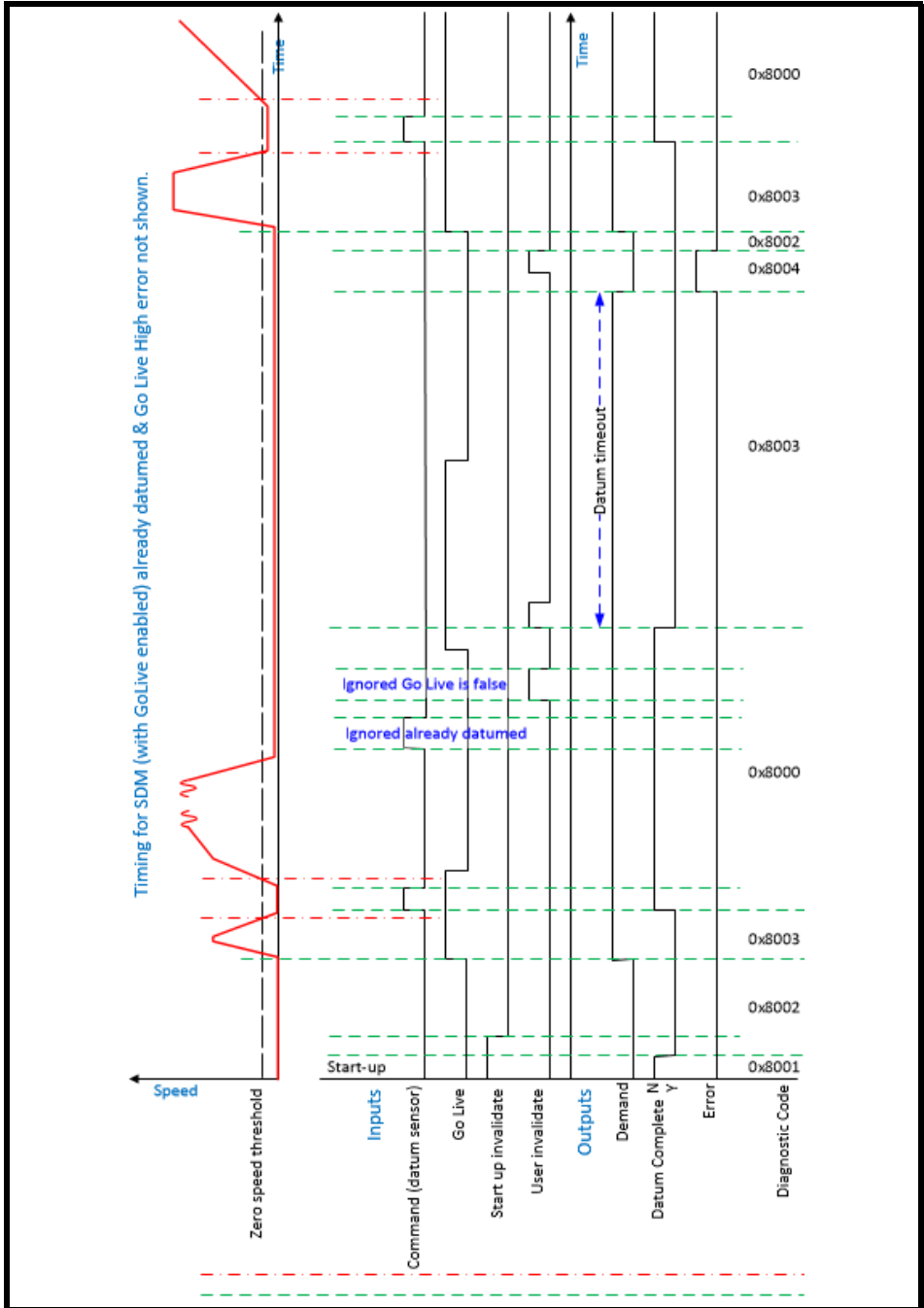

Figure 8-51 Timing Diagram when Go Live Enabled



Information	Introduction	Technical Safety Features	Installation	Connect Configuration Tool Introduction	Start Up	Validation	<b>Motion Safety Function Details</b>	Diagnoses and Maintenance	Key Safety Data	Version Control (Amendments)
-------------	--------------	---------------------------	--------------	---	----------	------------	---------------------------------------	---------------------------	-----------------	------------------------------

## 8.15 Safely Limited Position, SLP

The purpose of this function is to monitor the position of the axis and if it exceeds the defined envelope set the Demand to FALSE and enter an error state.

There are 2 possible modes, Stopping Distances Not Calculated and Stopping Distances Calculated, where a prediction of a position breach is used instead of an actual exceed. This uses deceleration values supplied by the user, these will typically be the deceleration rates from the motion controller trapezoid for deceleration from positive velocity (quadrant 2) or deceleration from negative velocity (quadrant 4). The function calculates the stopping distance based on the given deceleration every cycle and takes it into account when monitoring position if it predicts that the system cannot stop without breaching the position envelope then the function immediately enters its error state and sets its safety demand output to FALSE.

This behaviour can be turned off independently for each deceleration quadrant by entering 0 as the deceleration, in which case the error will not be raised until the axis breaches the envelope.



**WARNING**

The stopping distance prediction is necessarily simple and takes no account of the current axis dynamics or what happens after an error is raised, the function will not automatically recover should the axis stop without breaching the envelope. Conversely if the error is triggered at a point when the axis could stop close to the position limit, but the given deceleration is not achieved then the function can do nothing about it. The axis dynamics may be such that the axis cannot stop within the predicted stopping distance, in which case it will overshoot.

**Figure 8-52 Safe Position Monitoring with and without stopping distance prediction (a square velocity profile is shown for simplicity)**

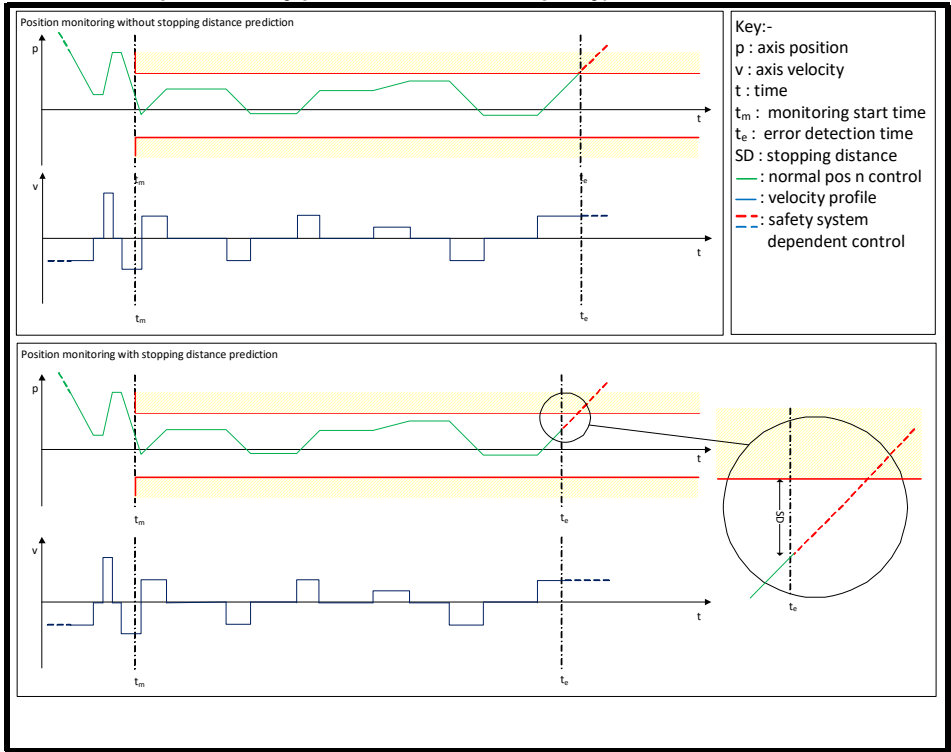

To ease machine construction an absolute encoder can be mounted on the machine reporting any position. The primary encoder must have enough range so that the entire range of motion between the 2 position limits is less than its range. The MiS2x0 takes account of an encoder position wrap, allowing one wrap in each direction. The offset applied by the Datum coupled with the wrap detection enables the MiS2x0 to align the encoder readings with the datum allowing use of the full range of the encoder.

When using AB and SC encoders they are automatically assigned a 25-bit range by the module's secondary encoder processors. The primary encoder 25 bit range must be sufficient to cover the entire range of motion between the 2 position limits. The MiS2x0 takes account of an encoder position wrap, allowing one wrap in each direction. The offset applied by the Datum coupled with the wrap detection enables the MiS2x0 to align the encoder readings with the datum allowing use of the full range of the encoder.

A single standard encoder will not allow the system to reach SIL3 and a risk assessment will be required to determine the achievable SIL level for any encoder arrangement. Including a second encoder incremental or absolute encoder on the secondary encoder input channel may allow SIL3 to be reached for the system. We recommended that an absolute encoder is used for the primary encoder.

A single SIL3 safety encoder using EnDat 2.2 on the primary encoder channel may achieve SIL3 for the system.

### **Interaction with Safe Datum (SDM)**

When SDM is activated the following applies:

When the output "Datum Required" is FALSE, all position monitoring function primary demand outputs are set to TRUE to allow STO to be deactivated (TRUE) and motion to occur. All other position monitoring function status outputs are set to FALSE and the function diagnostic code is set to 0x8FFF (datuming).

When "Datum Required" is TRUE all position monitoring functions behave normally as described below:

Following the completion of the datum the function state machine is returned to ready.

Each instance of SLP uses the encoder position modified by the safe datum offset.

If Safe Datum is set to be initiated at every power on, or at user request SLP can be used with any encoder type.

If Safe Datum is set once during commissioning, then SLP MUST only be used with absolute encoders.

#### **NOTE**

Once datumed the adjusted position (raw position + Safe position offset gained from datum function) will cause an Alarm to be raised if a wrap in either direction is detected and will cause the datum to be invalidated

#### **Errors and Reset:**

If an error occurs the function will set "Demand" to FALSE and will remain in this state until the source of the error clears. The function must then be reset by means of a rising edge applied to the reset input; Auto reset is not permitted for this function.

**When the error state is entered, by default in the configuration an alarm will be raised, and all the MiS2x0 Safety Module Safe Outputs will be set to SAFE. If this behaviour is not required by the user then they can disable the alarm generation using the Generate MSF Alarm parameter.**

**Figure 8-53 Diagrammatic representation of the Safely Limited Position function**

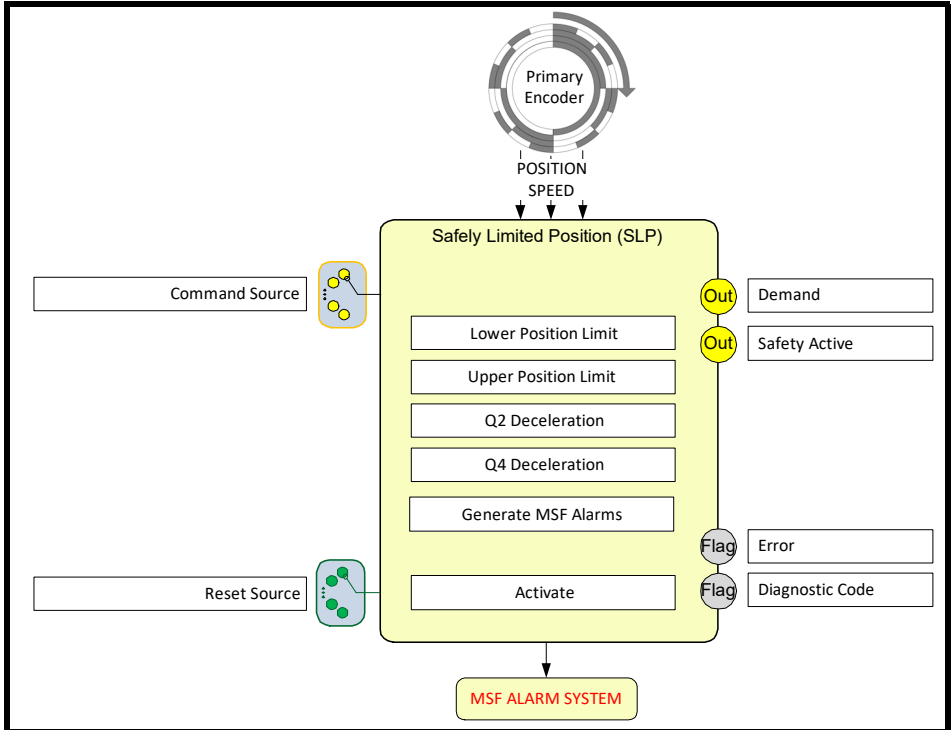

**Standards:**

EN 61800-5-2:2017

**4.2.3.4 Safely-Limited Position (SLP)**

The SLP function prevents the motor shaft from exceeding the specified position limit(s)

**Number of Instances:** 4

Name	Description
Command Source	Selects whether the function monitors for safe position or not 0.000: Default (Illegal will cause a configuration error, this must be set by the user) Numeric ID: for a valid Output Connector from another block <u>Value of Source Selected</u> TRUE: The Safe Position Limits are not monitored and if there is no reset error the "Demand" is set to TRUE FALSE: The Safe Position Limits are monitored and if one of them is predicted (using the stopping distances) to be exceeded, its envelope is exceeded the "Demand" is set to FALSE
Demand	Outputs the safety related response of the function TRUE: The function is initialised and has detected no errors. FALSE: The function is not initialised OR has detected an error OR is waiting for a reset after an error has cleared.
Safety Active	Provides a safe signal to indicate if the axis position is within the position thresholds, its use is optional, and it may be left disconnected. TRUE: The function is initialised AND position is within the envelope AND there are no errors. FALSE: The function is not initialised, OR has detected an error OR is has breached the envelope

Name	Description
Reset Source	Value that will provide the reset source, typically it will be System Reset but may be connected to any input to control the Reset. 0.002: Default, indicating that the function reset should share the System Reset input Numeric ID: From a Non-Safe Boolean Input (BIS) or from a SAFEBOOL if it is also connected to another Safe Output. Value of Source Selected Rising Edge (a change from FALSE to TRUE): The function will be reset if the error condition is no longer present Falling edge or unchanging TRUE or FALSE: No effect
Lower Position Limit	Minimum position in encoder counts that the axis should move to, if a position below the given value occurs an error and depending on the configuration, an alarm will be generated
Upper Position Limit	Maximum position in encoder counts that the axis should move to, if a position above the given value occurs an error and depending on the configuration, an alarm will be generated
Q2 Deceleration	The deceleration that will be used to calculate the stopping distance if the axis is moving forwards (position increasing) 0 means stopping distance not calculated Deceleration in encoder counts/s <sup>2</sup>
Q4 Deceleration	The deceleration that will be used to calculate the stopping distance if the axis is moving backwards (position decreasing) 0 means stopping distance not calculated Deceleration in encoder counts/s <sup>2</sup>
Generate MSF Alarm	Determines whether an alarm is raised when an error is detected which triggers all Safe Outputs to go Safe TRUE: Default, Alarm Raised and all safe outputs go SAFE FALSE: No alarm generated; demand output can be chained to another mitigating action
Error	Indicates that the function has detected an error condition TRUE: Error, check "Diagnostic Code" for details FALSE: No Error
Diagnostic Code	Diagnostic Fault Code, visible in Connect in Test Mode (see separate table)
Activate	This parameter is used to activate the function. Connect will set this value to TRUE when an MSF is selected. TRUE: function will be executed FALSE: function is deactivated.

**Figure 8-54 State Machine**

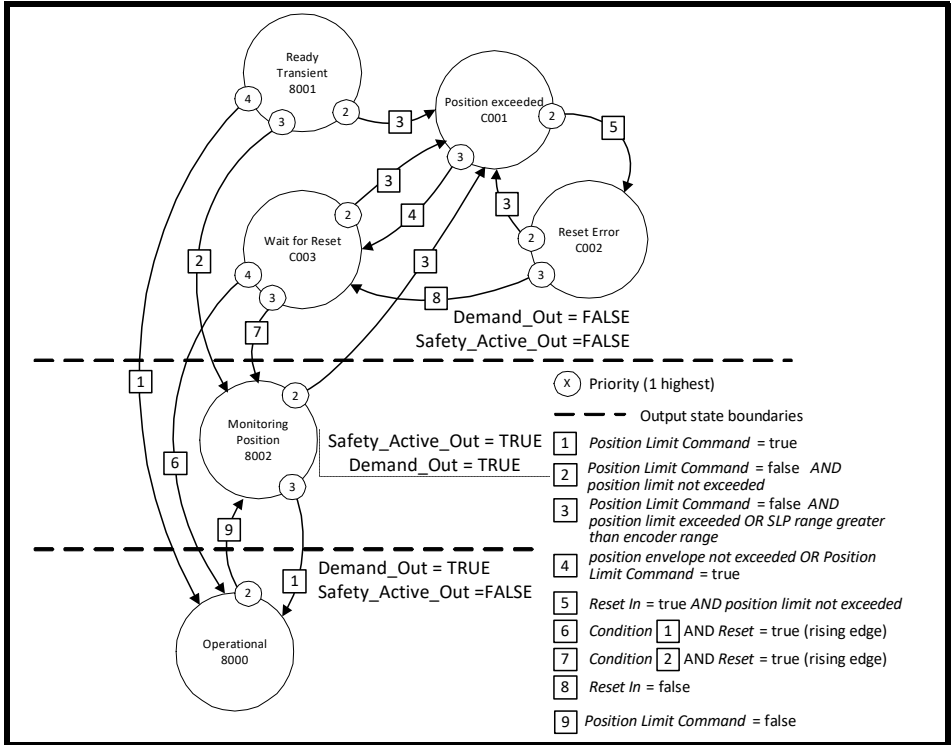

ERRORS THAT CAN TRIGGER ALARMS - ALL SAFE OUTPUTS GO SAFE		
Code	State	Description
C001	Position Exceeded	Occurs when the axis position breaches the envelope or depending on the configuration is predicted to breach the envelope OR SLP range is greater than encoder range. In this state: "Demand" = FALSE, "Safety Active" = FALSE
C002	Reset Error	Occurs if the reset signal is high when an error clears In this state: "Demand" = FALSE, "Safety Active" = FALSE
C003	Wait for Reset	Occurs after an error state once the error condition has cleared, a rising edge on the error input is required to leave the state In this state: "Demand" = FALSE, "Safety Active" = FALSE
DIAGNOSTIC ERRORS - Information for the User		
8000	Operational	Function is not monitoring position and the axis may go to any possible position without the function causing an error or alarm. To enter this state the Command Source = TRUE In this state: "Demand" = TRUE, "Safety Active" = FALSE
8001	Ready	A transient state that occurs for 1 cycle at start up, allows inputs to be checked before any output re set to TRUE. In this state: "Demand" = FALSE, "Safety Active" = FALSE
8002	Monitoring position	Function is monitoring position and the axis should remain within the position envelope to avoid an error. To enter this state the Command Source = FALSE In this state: "Demand" = TRUE, "Safety Active" = TRUE
8FFF	Datuming	Function is frozen for datum to complete, the Demand output is held on

Information
Introduction
Technical Safety Features
Installation
Connect Configuration Tool Introduction
Start Up
Validation
Motion Safety Function Details
Diagnostics and Maintenance
Key Safety Data
Version Control (Amendments)



## 8.16 Safe Direction, SDI

This function tests the encoder signals and sets its output to TRUE if the axis is moving in the selected direction, otherwise the output is set to FALSE. An integrator allows a configurable amount of motion in the opposite direction if required.

Figure 8-56 Graph of SDI function

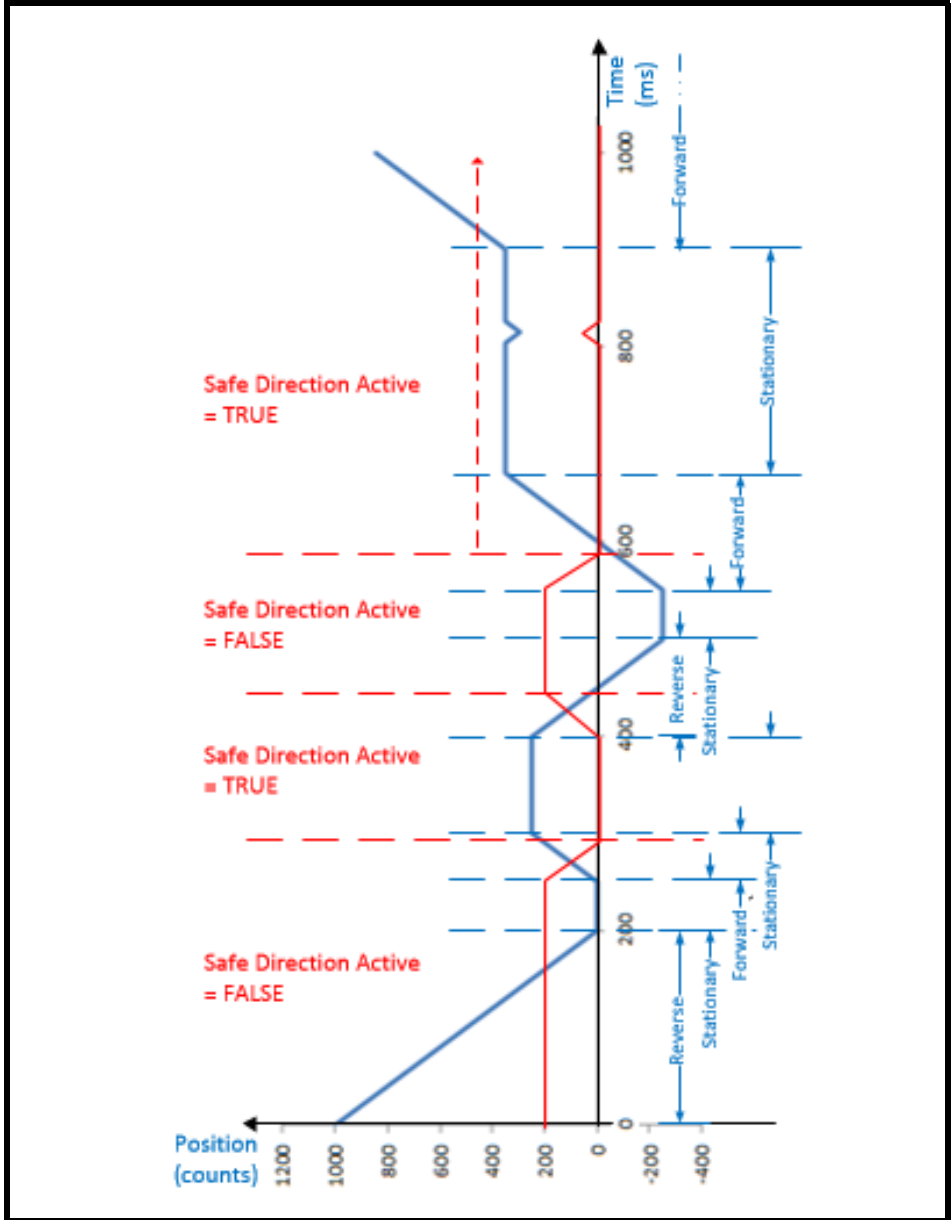
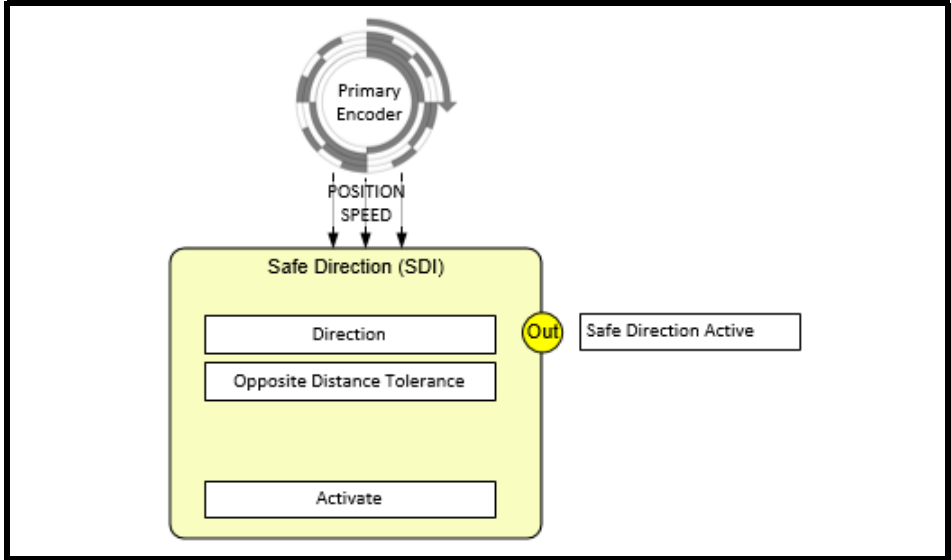

Figure 8-56 Graph of SDI function set for forward direction with a maximum reverse distance of 200 counts, showing that a short excursion (at time 800) in the opposite direction can be tolerated if required, and the equivalent forward motion required to clear the accumulated opposite motion. The accumulator value over time is shown as a solid red line.

**Figure 8-57 Diagrammatic representation of the Safe Direction function**



**Standards:**

IEC 61800 -5-2 : 2017

Clause 4.2.4.11 Safe Direction (SDI)

The SDI function prevents the motor shaft from moving in the unintended direction.

**Number of Instances: 2**

Name	Description
Safe Direction Active	Outputs the safety related response of the function TRUE: The function is initialized, and the axis speed is travelling in the required direction. FALSE: The function is not initialized, OR and the axis speed is traveling or has travelled too far in the opposite direction.
Direction	The direction to be monitored. 0 – Forward, select for motion with increasing position feedback 1 – Reverse, select for motion with decreasing position feedback
Opposite Distance Tolerance	The accumulated distance in encoder counts that the axis is allowed to travel in the direction opposite to that selected.
Activate	This parameter is used to activate the function. Connect will set this value to TRUE when an MSF is selected. TRUE: function will be executed FALSE: function is deactivated

Behaviour by cycle in priority order (behaviour is defined by the first row where the checks are TRUE)						
	Checks Made					
	Direction (as indicated by sign of speed)	Opposite Distance Tolerance (ODT)	ODT Reached Flag	Opposite Distance Accumulator Value after Position Change Added	Actions Taken during Evaluation (apart from setting output)	Output State after SDI Evaluation
	Stationary	ODT = 0	Not Checked	Not Checked	None	FALSE
	Stationary	ODT > 0	FALSE	Not Checked	None	TRUE
	Stationary	ODT > 0	TRUE	Not Checked	None	FALSE
✓	In Required Direction	ODT = 0	Not Checked	Not Checked	None	TRUE
✗	In Opposite Direction	ODT = 0	Not Checked	Not Checked	None	FALSE
✓	In Required Direction	ODT > 0	FALSE	Value <= 0	Set Accumulator to 0	TRUE
✓	In Required Direction	ODT > 0	TRUE	Value < 0	Set Accumulator to 0 Set ODT Reached Flag to FALSE	TRUE
✓	In Required Direction	ODT > 0	FALSE	Value > 0 AND Value < ODT	None (Accumulator Emptying but ODT Not Reached)	TRUE
?	In Required Direction	ODT > 0	TRUE	Value >= 0	(Accumulator Emptying after ODT Reached)	FALSE
?	In Opposite Direction	ODT > 0	FALSE	Value < ODT	None (Accumulator Filling but ODT Not Reached)	TRUE
✗	In Opposite Direction	ODT > 0	FALSE	Value >= ODT	Set ODT Reached Flag to TRUE Limit Accumulator to ODT (Accumulator Full)	FALSE

## 8.17 Safe Brake Control, SBC

This function takes a safe input and if the input is TRUE and other conditions (dependent on the operational mode) are met it will set its output to TRUE, conversely if the input is FALSE it will set its output to FALSE (except in the case of mode 2 (holding brake) where it will wait for the axis to stop before setting the output to FALSE).



The Emergency Brake Mode must not be used when the MiS2x0 is likely to be deliberately or inadvertently deenergised during the brake cooling time as the timer will be reset. Alternatively, in order to ensure safe operation, the brake rest timer can be set so it always runs at power up meaning that the brake cannot be lifted until the time has expired.

**WARNING**

This function provides an output for controlling a brake, it can work in 4 modes Operational, Holding Braking, Emergency or Emergency with start-up timer.

**Operational Brake Mode:** The output will go FALSE as soon as the brake control input goes FALSE. It is intended for use with overhauling or high inertia loads where simply setting the STO to FALSE on an MSF alarm condition is an inadequate response. The brake's energy dissipation capability should be sufficient to cope with repeated braking according to the needs of the application.

**Holding Brake Mode:** The brake will not be applied (function output to FALSE) until the axis reaches zero speed. This mode must not be used with overhauling or high inertia loads and the machine must come to a halt when no power is applied.

**Emergency Brake Mode:** The output will go FALSE as soon the brake control input goes FALSE, an adjustable timer will prevent a reset until a given time from brake actuation. It is intended for use with overhauling or high inertia loads where simply setting the STO to FALSE on an MSF alarm condition is an inadequate response, but where the brake is only capable of intermittent operation. An independent 24 V supply should be used to keep the timer active when the drive power is off (or use mode 4 if start up delays are acceptable).

**Emergency Brake Mode with Start-up Timer:** This is the same as Emergency Mode but forces the brake cooling timer to run on power up, meaning there will be a delay before the brake can be released.

**NOTE**

This function provides a brake control signal to release and apply the brake. The application of the brake follows a sequence depending on the braking mode selected. If a command to release the brake () is applied before the MSF completes the sequence to bring the machine to a stop, an error is raised which will require the SBC\_RELEASE\_BRAKE signal to be removed (made FALSE) and a rising edge on the reset to be applied to restart the MSF a reset on the reset source.

**Errors and Reset:**

If an error occurs the function will set "Demand" to FALSE and will remain in this state until the source of the error clears. The Release Brake Command must be set FALSE, and function reset by means of a rising edge applied to the reset input;

**When the error state is entered, by default in the configuration an alarm will be raised, and all the MiS2x0 Safety Module Safe Outputs will be set to SAFE. If this behaviour is not required by the user then they can disable the alarm generation using the Generate MSF Alarm parameter.**

**Figure 8-58 Diagrammatic representation of the Safe Brake Control function**

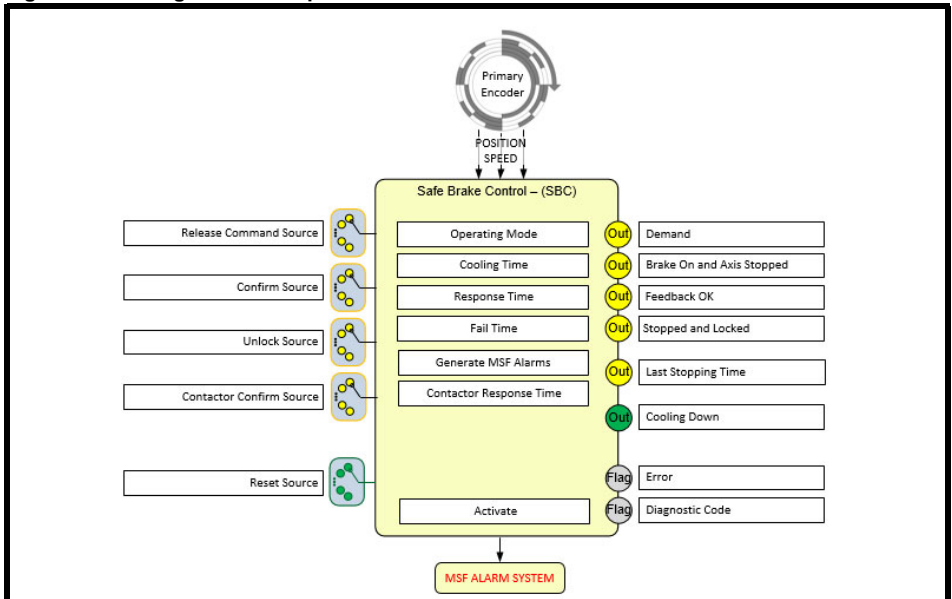

**Standards:**

BS EN 61800-5-2:2017

Section 4.2.5 This function provides a safe output signal(s) to control an external brake(s).

**Number of Instances:** 1

Name	Description
Release Command Source	Provides the command to release or apply the brake 0.000: Default (Illegal will cause a configuration error, this must be set by the user) Numeric ID: for a valid Output Connector from another block <u>Value of Source Selected</u> TRUE: Release brake command FALSE: Apply brake command
Confirm Source	An optional confirmation signal from the brake, if enabled, it also provides the signal for the Brake On and Axis Stopped output and is used to check the operation of the brake 0.000: Default (Illegal will cause a configuration error, this selector must be set by the user) 0.001: Disable, a Brake On signal is not required, if set to this value then the Brake On input is not used and the brake operation is only tested by checking the speed. Numeric ID: for a valid Output Connector from another block, this is required for Brake On <u>Value of Source Selected</u> TRUE: Brake applied FALSE: Brake is not applied
Unlock Source	Optionally lock the brake and prevent it being released. If the Brake Control output is FALSE when the Unlock Brake signal becomes FALSE, the Brake Control output will remain FALSE (brake will not be released). The Brake Control output will not follow Release Command until the Unlock Brake signal becomes TRUE and there are no errors. 0.000: Default (Illegal will cause a configuration error, this selector must be set by the user) 0.001: Disable, Unlock Brake Signal is not required Numeric ID: for a valid Output Connector from another block <u>Value of Source Selected</u> TRUE: The brake can be released on command. FALSE: The brake will not be released.
Contact Confirm Source	An optional confirmation signal from the contactor, if enabled, it provides a signal to check the operation of the contactor 0.000: Default (Illegal will cause a configuration error, this selector must be set by the user) 0.001: Disable: A contactor signal is not required, if set to this value then the contactor is not tested Numeric ID: for a valid Output Connector from another block <u>Value of Source Selected</u> TRUE: Contactor closed FALSE: Contactor not closed
Demand	Outputs the safety related response of the function (also referred to as Brake Control) Additionally, the brake will not be released if the Unlock Source is FALSE when the Release Command Source goes from FALSE to TRUE. The output changes state as requested by Release Command Source combined with and other inputs or conditions as required by the mode of operation. Evaluation is completed within one cycle. TRUE: Release brake (only if Release Command Source is also TRUE and no errors) FALSE: Apply Brake
Brake On and Axis Stopped	Indicates that the brake is applied, and the axis is at zero speed. The output will always be FALSE if the Confirm Source signal selector is disabled. In the case where the brake cannot be monitored and creepage needs to be detected, a function such as SOS or SLS can be configured to provide creepage detection. TRUE: Its value is TRUE if Brake Control is FALSE AND the axis is at or below the Zero Speed Threshold AND Confirm Source is enabled AND Confirm Source is TRUE AND SBC has detected no errors. FALSE: Its value is FALSE in all conditions apart from those identified for the TRUE Condition.

Information
Introduction
Technical Safety Features
Installation
Connect Configuration Tool Introduction
Start Up
Validation
<b>Motion Safety Function Details</b>
Diagnostics and Maintenance
Key Safety Data
Version Control (Amendments)

Name	Description
Feedback OK	<p>This output is normally TRUE. When the Brake Control the Contactor confirm source and the Brake Confirm do not match it is set False.</p> <p>If the axis fails to stop in the time prescribed in Brake Fail Time or the Brake Contactor or Brake Confirm Fails to change state either when Brake Control is applied or released, within the time prescribed by the Brake Response Time, this output and the Brake Control are set to FALSE until the function is reset.</p> <p>TRUE: Its value is TRUE if no error is detected FALSE: Its Value is FALSE if the Zero Speed Tolerance is exceeded after the braking sequence (Operational, Emergency or Holding brake sequence) has completed or if the brake response time is exceeded when the brake is applied or released. Additionally, it shall be false if there is a mismatch or true if there is no mismatch and no error has occurred during the brake response time. This signal is updated 1 cycle after entering states POWERED_STOP_PROBLEM, OPERATIONAL and STOPPING.</p>
Stopped and Locked	<p>TRUE: Axis has stopped, and brake lock is applied FALSE: All other cases</p>
Reset Source	<p>Value that will provide the reset source, typically it will be System Reset but may be connected to any input to control the Reset.</p> <p>0.002: Default, indicating that the function reset should share the System Reset inputNumeric ID: for a valid SAFEBOOL or Boolean Connector from another logic block or input. <u>Value of Source Selected</u></p> <p>Rising Edge (a change from FALSE to TRUE): The function will be reset if the error condition is no longer present Falling edge or unchanging TRUE or FALSE: No effect</p>
Cooling Down	<p>TRUE: Axis has stopped, and brake cooling timer is active, brake cannot be released FALSE: All other cases</p> <p><b>NOTE</b></p> <p>The Cooling Down flag is set to TRUE to indicate brake cooling down, but only set to TRUE if cooling down in Brake cooling state or in Wait for Reset RE or Reset Error states. When transitioning to other states (e.g. failure to stop or feedback failed states), the flag is set to FALSE.</p>
Operating Mode	<p>Defines the mode of operation for the function.</p> <p>1: Operational Brake 2: Holding Brake 3: Emergency Brake 4: Emergency Brake + Start Up Timer</p>
Cooling Time (EMERGENCY MODES ONLY)	<p>Defines the cooling time required by the emergency brake after its application to halt the machine. The machine can only recommence operation when the brake cooling time has elapsed.</p> <p>0: Default value The cooling time is specified in units of 1ms. The range of value is from 0 to a maximum of 4294967295 ms</p>
Response Time	<p>Defines the maximum time between the Brake Control commanding the application of the brake, and the Brake On reporting (Confirm Source Input) that the brake has been applied or between the Brake Control commanding the release of the brake and the Brake On reporting (Confirm Source Input) that the brake has been released. If the specified response time is exceeded the function will enter an error state requiring the removal of the fault condition and a reset (Rising Edge) before operation can continue.</p> <p>0: Default value The Brake Response Time is specified in units of 1ms. The range of value is from 0 to a maximum of 65535 ms</p>

Name	Description
Fail Time	Defines the maximum time between the Brake Release commanding the application of the brake and the detection of the machine speed being equal to or below the Zero Speed Threshold. (Also referred to as Brake Fail Time). If the specified response time is exceeded the function will enter an error state requiring the removal of the fault condition and a reset before operation can continue. 0: Default value The Fail Time is specified in units of 1ms. The range of value is from zero to a maximum of 65535 ms
Zero Speed Threshold	Defines the speed threshold below which the machine is regarded to be stationary. 0: Default value The permissible range of values is from 0 to a maximum of 4294967295 encoder counts per second
Contactorm Response Time	Defines the maximum time between the Brake Control commanding the application of the brake, and the Contactor input reporting that the contactor has opened or between the Brake Release commanding the release of the brake and the Contactor signal reporting that the contactor has closed. If the specified response time is exceeded the function will enter an error state requiring the removal of the fault condition and a reset (Rising Edge) before operation can continue. 0: Default value The Brake Response Time is specified in units of 1 ms. The range of value is from 0 to a maximum of 65535 ms
Speed Control Tolerance	Upper limit on the dither of speed feedback that is allowed during slowdown, speed limit, and zero speed monitoring.
Generate MSF Alarm	Determines whether an alarm is raised when an error is detected which triggers all Safe Outputs to go Safe. TRUE: Default, Alarm Raised and all safe outputs go SAFE FALSE: No alarm generated; demand output can be chained to another mitigating action
Last Stopping Time	Provides the time in ms that the brake took to stop. The parameter is updated each time a stop is achieved with no errors. When a braking cycle commences the timer is set to zero. If an error occurs the last stopping time will be set to zero.
Error	Indicates that the function has detected an error condition TRUE: Error, check "Diagnostic Code" for details FALSE: No Error
Diagnostic Code	Diagnostic Fault Code, visible in Connect in Test Mode (see separate table)
Activate	This parameter is used to activate the function. Connect will set this value to TRUE when an MSF is selected. TRUE: function will be executed FALSE: function is deactivated.

Information
Introduction
Technical Safety Features
Installation
Connect Configuration Tool Introduction
Start Up
Validation
<b>Motion Safety Function Details</b>
Diagnostics and Maintenance
Key Safety Data
Version Control (Amendments)

Figure 8-59 State Machine

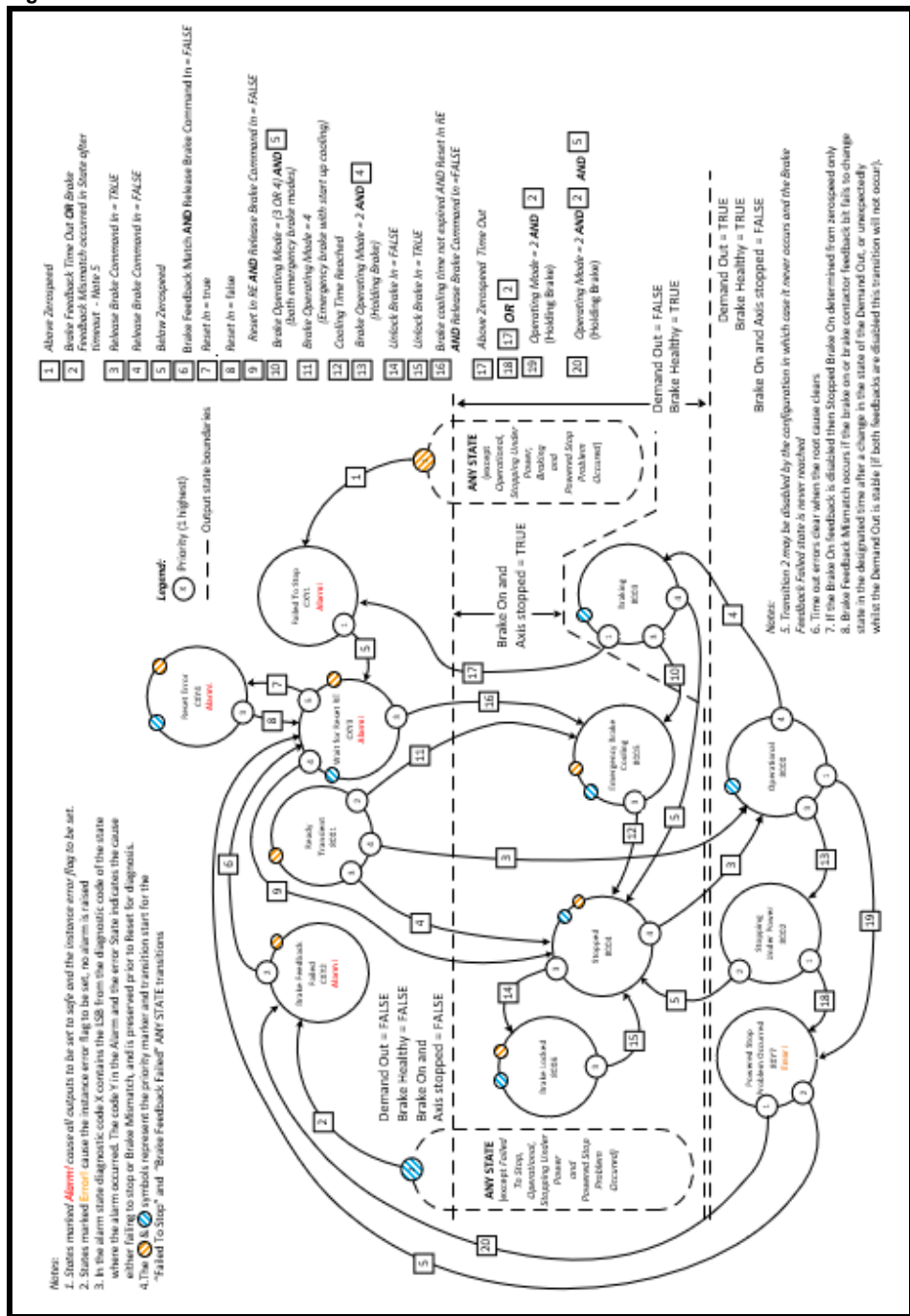
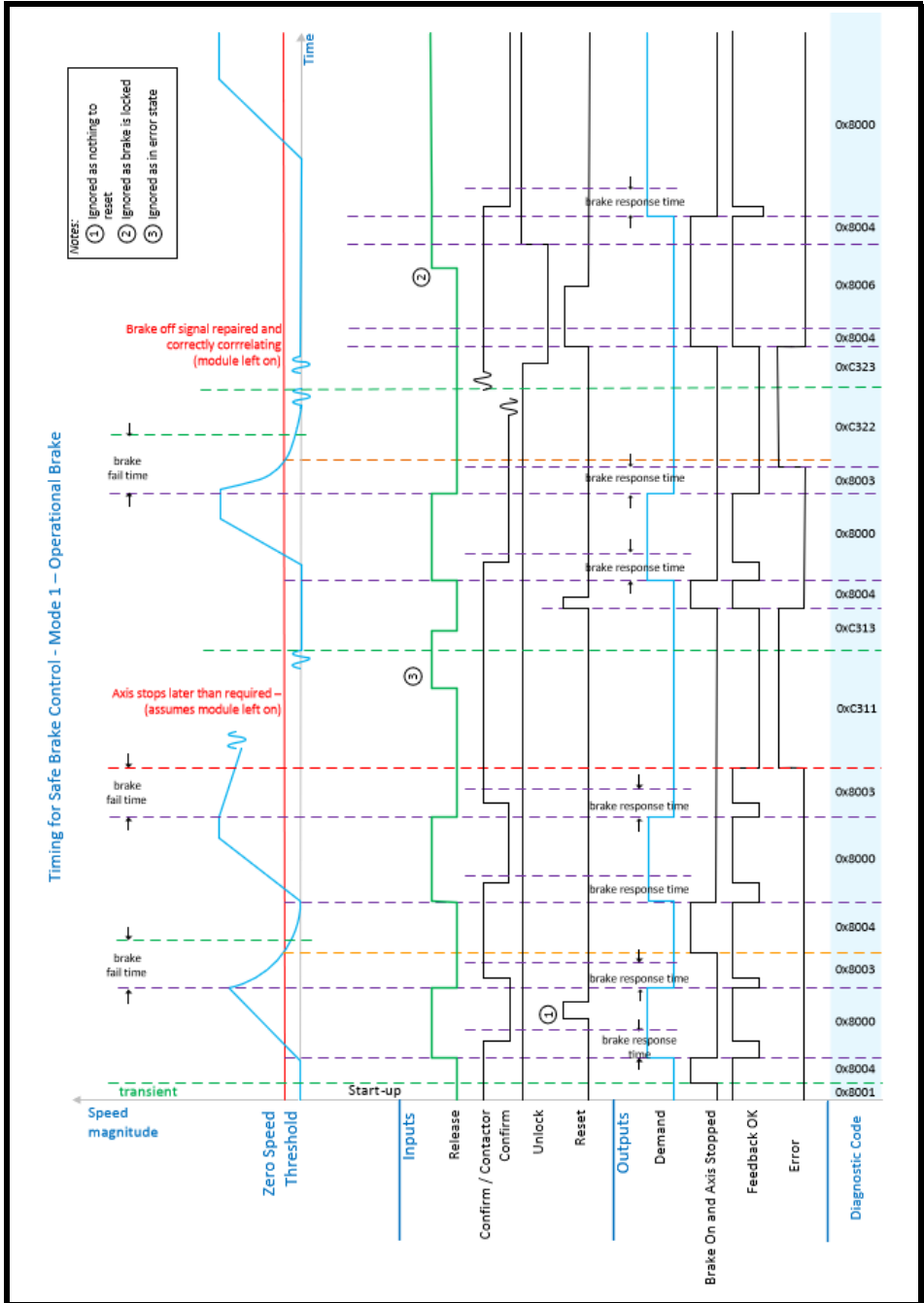

Figure 8-60 Timing Diagram, Mode 1



Information
Introduction
Technical Safety Features
Installation
Connect Configuration Tool Introduction
Start Up
Validation
<b>Motion Safety Function Details</b>
Diagnostics and Maintenance
Key Safety Data
Version Control (Amendments)

Figure 8-61 Timing Diagram, Mode 2

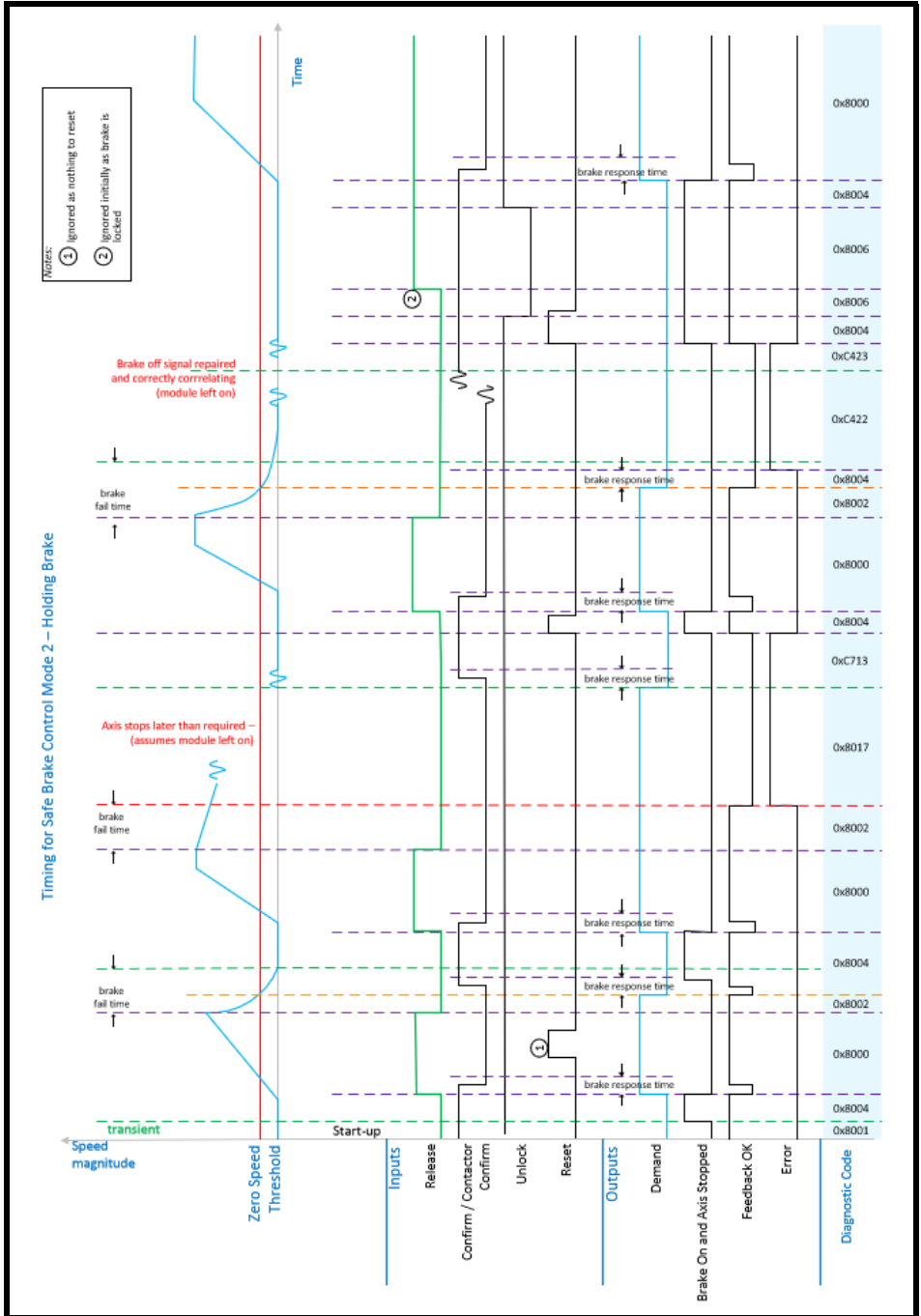
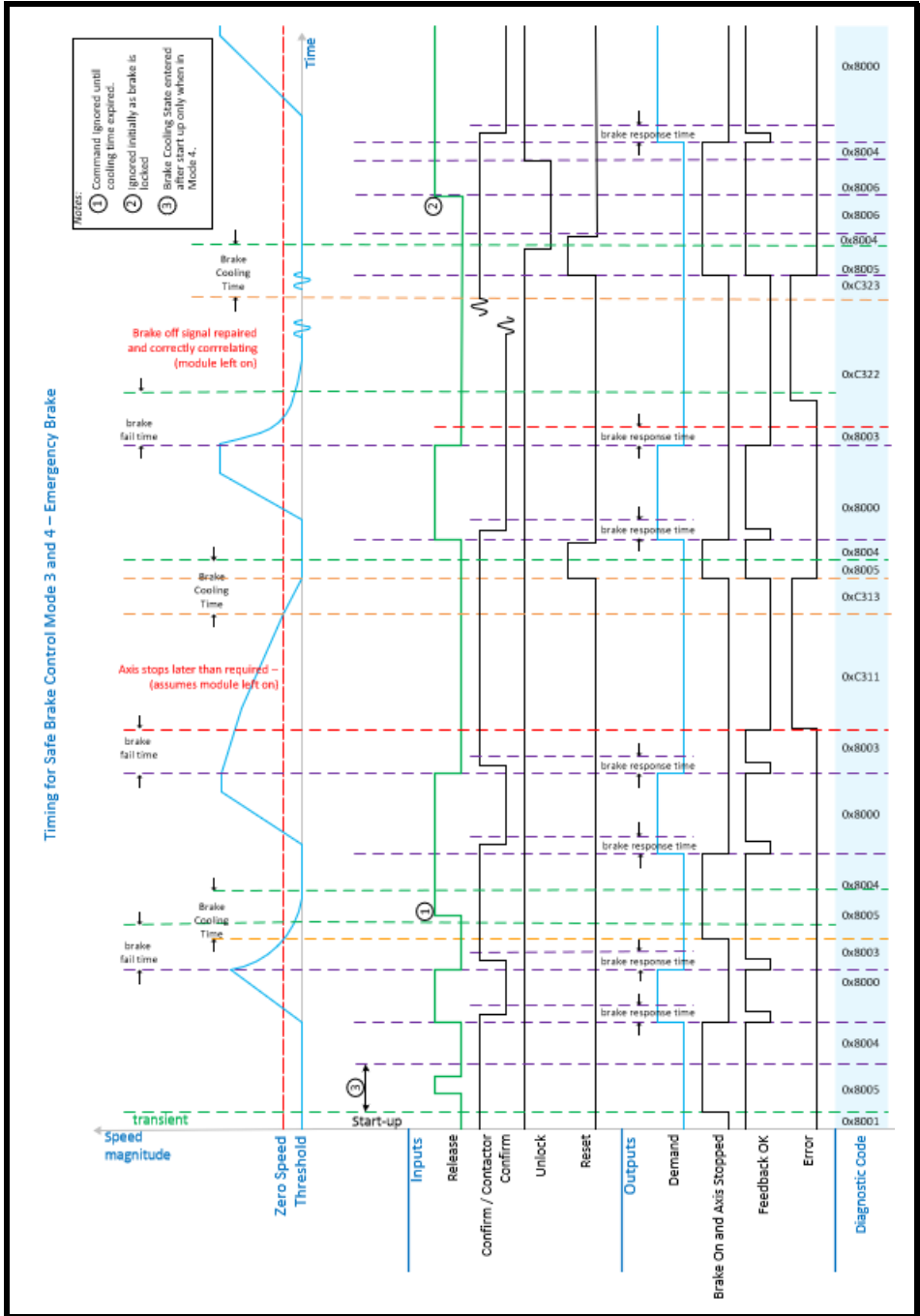

Figure 8-62 Timing Diagram, Mode 3 and 4



Information
Introduction
Technical Safety Features
Installation
Connect Configuration Tool Introduction
Start Up
Validation
<b>Motion Safety Function Details</b>
Diagnostics and Maintenance
Key Safety Data
Version Control (Amendments)

**ERRORS THAT CAN TRIGGER ALARMS - ALL SAFE OUTPUTS GO SAFE**

Code	State	Description
CX11	Failed to Stop	This state can be reached in Mode = Emergency or Operational. The state is entered when the speed of the machine is not equal or less than the Brake Zero Speed Threshold within the required time. In this state: "Demand" = FALSE, "Error" = TRUE, "Feedback OK" = FALSE, "Brake On and Axis Stopped" = FALSE
CX12	Brake Feedback Failed	Mode = Emergency or Operational The brake feedback if utilized indicates brake not operated within time limit or an unexpected brake feedback mismatch has occurred within a state. In this state: "Demand" = FALSE, "Error" = TRUE, "Feedback OK" = FALSE, "Brake On and Axis Stopped" = FALSE
CXY3	Wait for Reset RE	Occurs after an error state once the error condition has cleared. Brake Control is FALSE and a rising edge on the Reset input is required to leave the state In this state: "Demand" = FALSE, "Brake On and Axis Stopped" = FALSE, "FeedbackOk" = FALSE, "Error" = TRUE
CXY4	Reset Error	Occurs if the reset signal is high when the error condition clears. In this state: "Demand" = FALSE, "Brake On and Axis Stopped" = FALSE, "FeedbackOk" = FALSE, "Error" = TRUE
DIAGNOSTIC ERRORS – Information for the User		
8000	Operational Brake Released	In this state the brake is released allowing the machine to run. In this state the outputs are :- "Demand" = TRUE, "Brake On and Axis Stopped" = FALSE, "FeedbackOk" = TRUE, "Error" = FALSE
8001	Ready Transient	This state is used as the starting point for the function.
8002	Stopping under Power	In this state state SBC is in holding brake mode, and is waiting for the drive to stop the machine In this state the outputs are :- "Demand" = TRUE, "Brake On and Axis Stopped" = FALSE, "FeedbackOk" = TRUE, "Error" = FALSE
8003	Braking	In this state SBC is in Emergency Brake or Operational Brake mode and is waiting for the brake to stop the axis. The time to stop the axis is monitored to check that it stops within the time specified by the Brake Response Time. In this state the outputs are :- "Demand" = FALSE, "Brake On and Axis Stopped" = FALSE, "FeedbackOk" = TRUE, "Error" = FALSE
8004	Stopped	In this state the axis has stopped without breaching any check and any cooling time or locking requirement is inactive In this state the outputs are :- "Demand" = FALSE, "Brake On and Axis Stopped" = TRUE, "FeedbackOk" = TRUE, "Error" = FALSE
8005	Emergency brake cooling	In this state the axis has stopped, and the function is waiting for the brake cooling time to elapse In this state the outputs are :- "Demand" = FALSE, "Brake On and Axis Stopped" = TRUE, "FeedbackOk" = TRUE, "Error" = FALSE

ERRORS THAT CAN TRIGGER ALARMS - ALL SAFE OUTPUTS GO SAFE		
Code	State	Description
8006	Brake locked	In this state the axis has stopped, and the Unlock signal is enabled and is FALSE In this state the outputs are :- "Demand" = FALSE, "Brake On and Axis Stopped" = TRUE, "FeedbackOk" = TRUE, "Error" = FALSE
80Y7	Powered Stop Problem Occurred	In this state SBC is in Holding brake mode. This state indicates that in holding brake mode only the axis did not stop in time, or a feedback mismatch occurred, no alarm is raised in this state as it is assumed that it is only the drive that can stop the axis and that activating STO would make the situation worse In this state the outputs are :- "Demand" = TRUE, "Brake On and Axis Stopped" = FALSE, "FeedbackOk" = FALSE, "Error" = TRUE

**NOTE**

After an error the release command source should be set FALSE (apply Brake) to be able to exit the Wait for Reset state. In the alarm state diagnostic code X contains the LSB from the diagnostic code of the state where the alarm occurred. The code Y in the Alarm and the error State indicates the cause either failing to stop or Brake Mismatch and is preserved prior to Reset for diagnosis.

Information
Introduction
Technical Safety Features
Installation
Connect Configuration Tool Introduction
Start Up
Validation
<b>Motion Safety Function Details</b>
Diagnostics and Maintenance
Key Safety Data
Version Control (Amendments)

## 8.18 Safe OR, SOR

This logic function tests its two safe inputs for their state, applies a logical OR and sets the output accordingly. Values are available to be read in Test Mode, if values are read from an activated function the current values are returned, if a read is made on a deactivated function the default value is returned. The function is only active if "Activate" has been set at design-time, the behaviour description below describes an activated function.

**Figure 8-63 Diagrammatic representation of the Safe OR function and Truth Table**

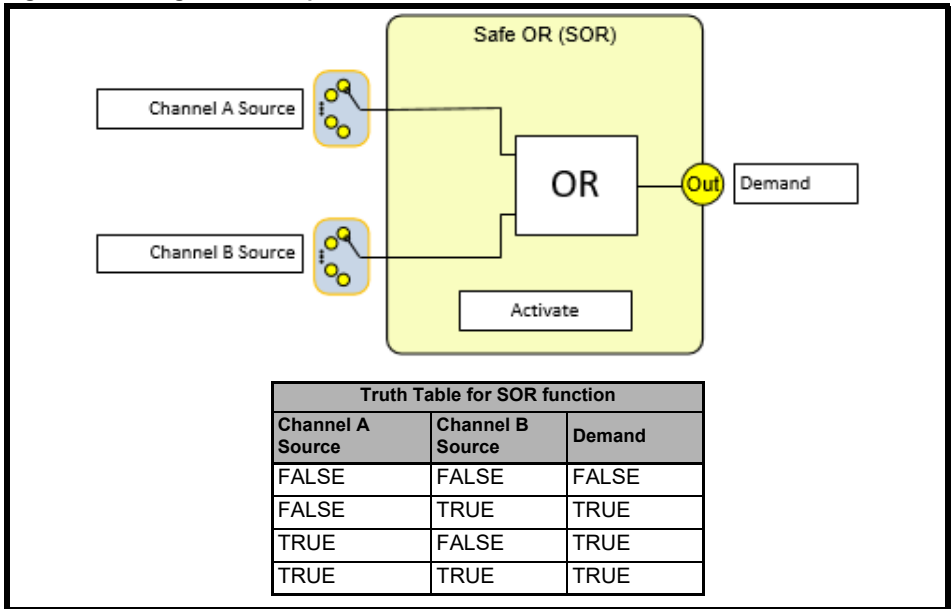

## 8.19 Safe Not OR, SNOR

This logic function tests its two safe inputs for their state, applies a logical NOR and sets the output accordingly. Values are available to be read in Test Mode, if values are read from an activated function the current values are returned, if a read is made on a deactivated function the default value is returned. The function is only active if “Activate” has been set at design-time, the behaviour description below describes an activated function.

**Figure 8-64 Diagrammatic representation of the Safe NOR function and Truth Table**

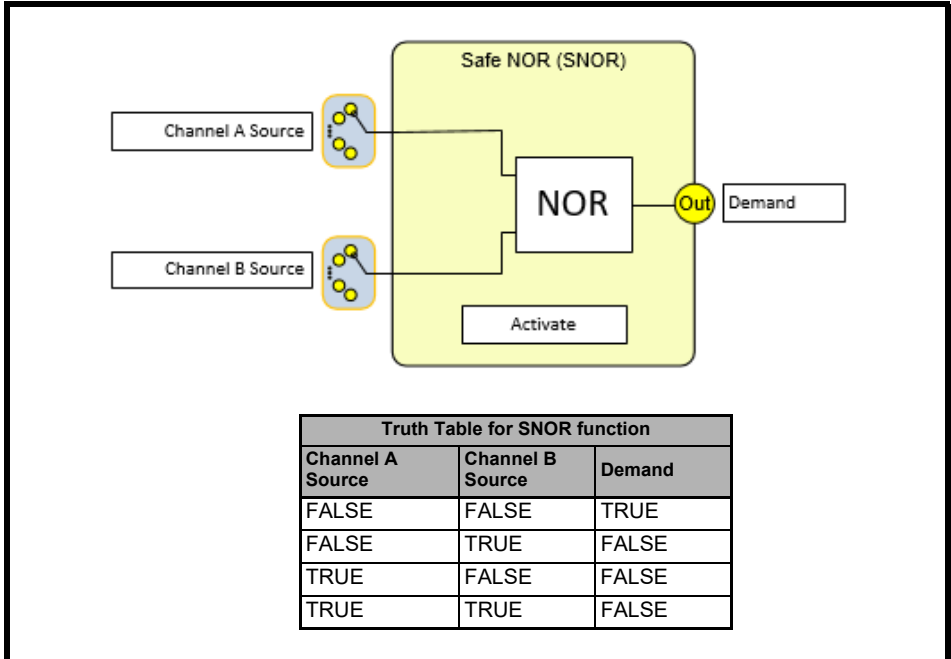

Name	Description
Channel A Source	Selects the safety signal that needs to be NORed with the value connected to “Channel B Source”. 0.000: Default (Illegal will cause a configuration error, this must be set by the user) <u>Value of Source Selected</u> TRUE: the meaning of the signal depends on the system. FALSE: the meaning of the signal depends on the system.
Channel B Source	Selects the safety signal that needs to be NORed with the value connected to “Channel A Source”. 0.000: Default (Illegal will cause a configuration error, this must be set by the user) <u>Value of Source Selected</u> TRUE: the meaning of the signal depends on the system. FALSE: the meaning of the signal depends on the system.
Demand	Outputs the safety related response of the function. FALSE: Demand for safety related response, request for safe state. TRUE: No demand for safety related response, request for operational state.
Activate	This parameter is used to activate the function. Connect will set this value to true when an MSF is selected. TRUE: function will be executed. FALSE: function is deactivated.

## 8.20 Safe Exclusive OR, SXOR

This logic function tests its two safe inputs for their state, applies a logical XOR and sets the output accordingly. There are eight available instances of this function for the user. Each can be activated or deactivated at design time only. Values are available to be read in Test Mode, if values are read from an activated function the current values are returned, if a read is made on a deactivated function the default value is returned. The function is only active if "Activate" has been set at design-time, the behaviour description below describes an activated function.

**Figure 8-65 Diagrammatic representation of the Safe XOR function and Truth Table**

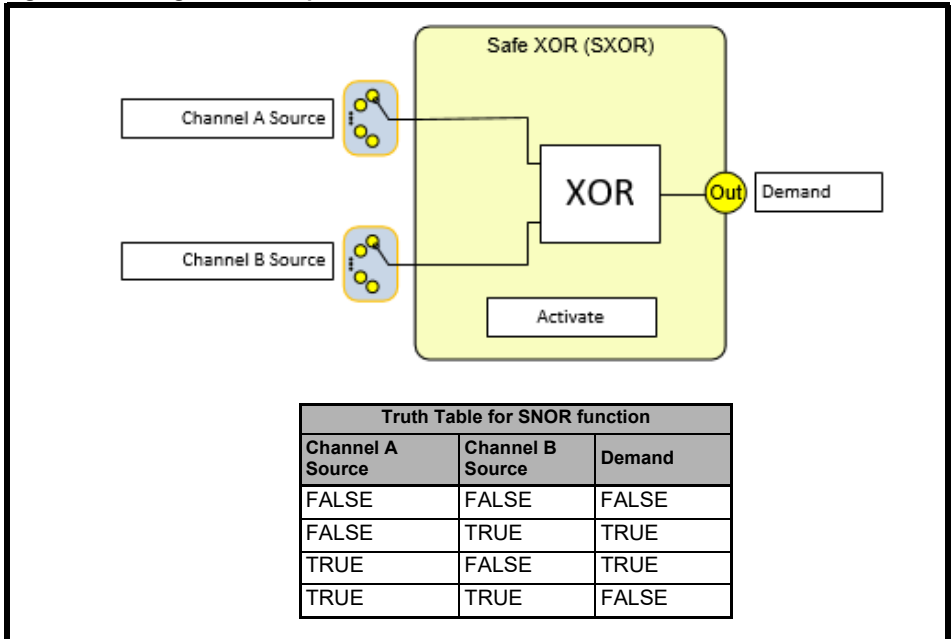

Name	Description
Channel A Source	Selects the safety signal that needs to be XORed with the value connected to "Channel B Source". 0.000: Default (Illegal will cause a configuration error, this must be set by the user) <u>Value of Source Selected</u> TRUE: the meaning of the signal depends on the system. FALSE: the meaning of the signal depends on the system.
Channel B Source	Selects the safety signal that needs to be XORed with the value connected to "Channel A Source". 0.000: Default (Illegal will cause a configuration error, this must be set by the user) <u>Value of Source Selected</u> TRUE: the meaning of the signal depends on the system. FALSE: the meaning of the signal depends on the system.
Demand	Outputs the safety related response of the function. FALSE: Demand for safety related response, request for safe state. TRUE: No demand for safety related response, request for operational state.
Activate	This parameter is used to activate the function. Connect will set this value to true when an MSF is selected. TRUE: function will be executed. FALSE: function is deactivated.

## 8.21 Safe Exclusive Not OR, SXNOR

This logic function tests its two safe inputs for their state, applies a logical XNOR and sets the output accordingly. Values are available to be read in Test Mode, if values are read from an activated function the current values are returned, if a read is made on a deactivated function the default value is returned. The function is only active if "Activate" has been set at design-time, the behaviour description below describes an activated function.

**Figure 8-66 Diagrammatic representation of the Safe XNOR function and Truth Table**

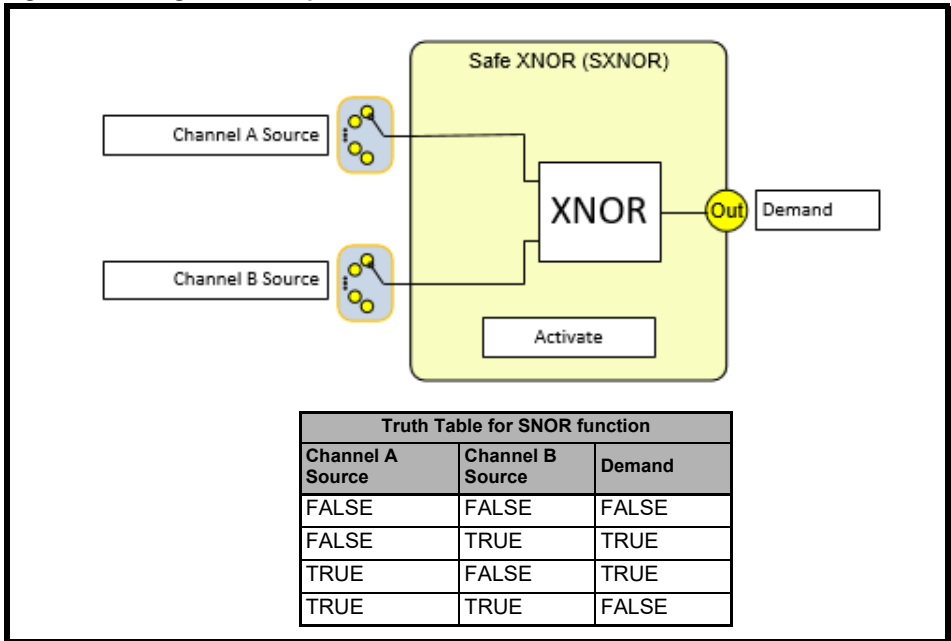

Name	Description
Channel A Source	Selects the safety signal that needs to be XNORed with the value connected to "Channel B Source". 0.000: Default (Illegal will cause a configuration error, this must be set by the user) <u>Value of Source Selected</u> TRUE: the meaning of the signal depends on the system. FALSE: the meaning of the signal depends on the system.
Channel B Source	Selects the safety signal that needs to be XNORed with the value connected to "Channel A Source". 0.000: Default (Illegal will cause a configuration error, this must be set by the user) <u>Value of Source Selected</u> TRUE: the meaning of the signal depends on the system. FALSE: the meaning of the signal depends on the system.
Demand	Outputs the safety related response of the function. FALSE: Demand for safety related response, request for safe state. TRUE: No demand for safety related response, request for operational state.
Activate	This parameter is used to activate the function. Connect will set this value to true when an MSF is selected. TRUE: function will be executed. FALSE: function is deactivated.

## 8.22 Safe AND, SAND

This logic function tests its two safe inputs for their state, applies a logical AND and sets the output accordingly. Values are available to be in Test Mode, if values are read from an activated function the current values are returned, if a read is made on a deactivated function the default value is returned. The function is only active if “Activate” has been set at design-time, the behaviour description below describes an activated function.

**Figure 8-67 Diagrammatic representation of the Safe AND function and Truth Table**

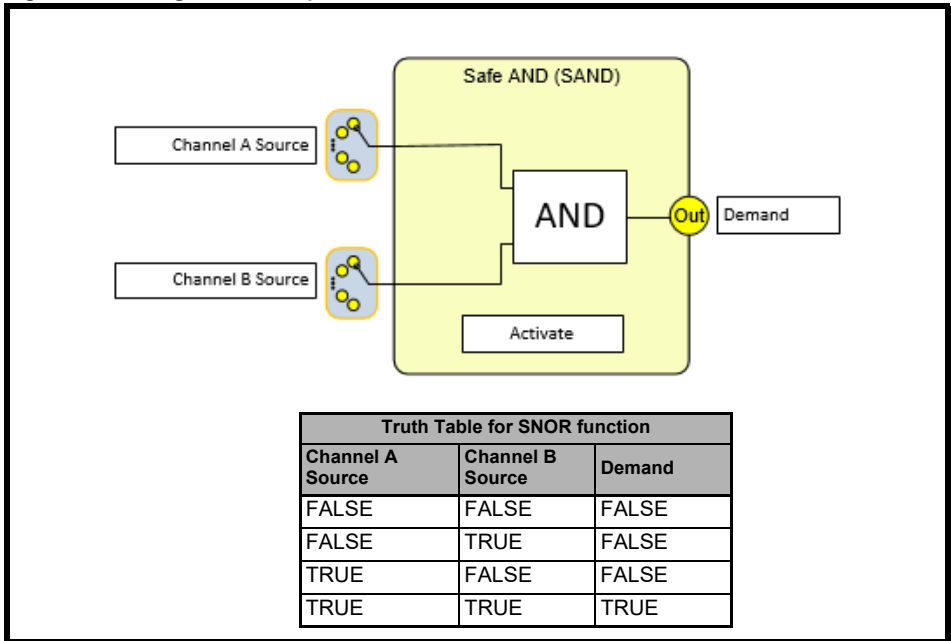

Name	Description
Channel A Source	Selects the safety signal that needs to be ANDed with the value connected to “Channel B Source”. 0.000: Default (Illegal will cause a configuration error, this must be set by the user) <u>Value of Source Selected</u> TRUE: the meaning of the signal depends on the system. FALSE: the meaning of the signal depends on the system.
Channel B Source	Selects the safety signal that needs to be ANDed with the value connected to “Channel A Source”. 0.000: Default (Illegal will cause a configuration error, this must be set by the user) <u>Value of Source Selected</u> TRUE: the meaning of the signal depends on the system. FALSE: the meaning of the signal depends on the system.
Demand	Outputs the safety related response of the function. FALSE: Demand for safety related response, request for safe state. TRUE: No demand for safety related response, request for operational state.
Activate	This parameter is used to activate the function. Connect will set this value to true when an MSF is selected. TRUE: function will be executed. FALSE: function is deactivated.

## 8.23 Safe Not AND, SNAND

This logic function tests its two safe inputs for their state, applies a logical NAND and sets the output accordingly. Values are available to be read in Test Mode, if values are read from an activated function the current values are returned, if a read is made on a deactivated function the default value is returned. The function is only active if "Activate" has been set at design-time, the behaviour description below describes an activated function.

**Figure 8-68 Diagrammatic representation of the Safe NAND function and Truth Table**

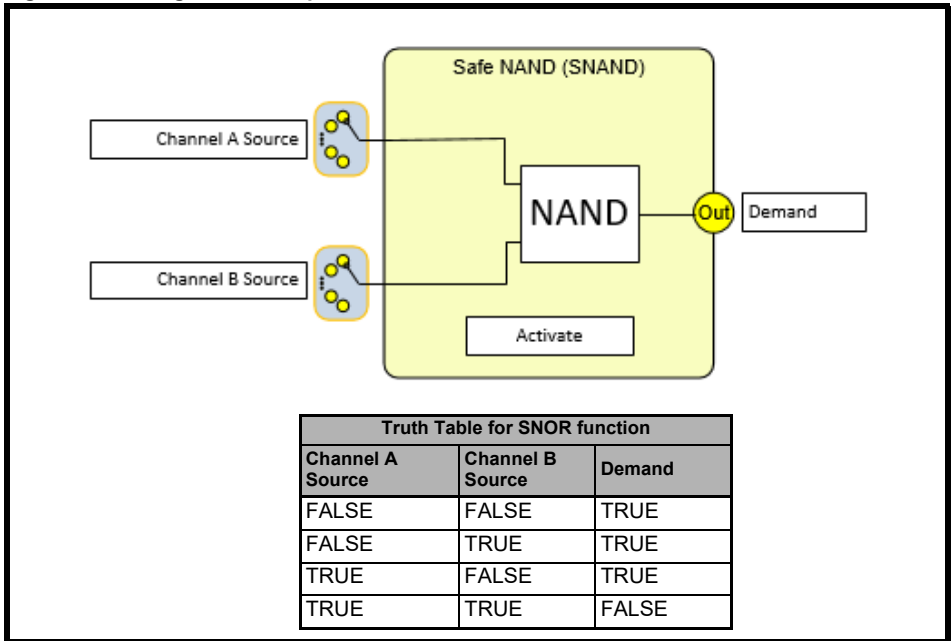

Name	Description
Channel A Source	Selects the safety signal that needs to be NANDed with the value connected to "Channel B Source". 0.000: Default (Illegal will cause a configuration error, this must be set by the user) <u>Value of Source Selected</u> TRUE: the meaning of the signal depends on the system. FALSE: the meaning of the signal depends on the system.
Channel B Source	Selects the safety signal that needs to be NANDed with the value connected to "Channel A Source". 0.000: Default (Illegal will cause a configuration error, this must be set by the user) <u>Value of Source Selected</u> TRUE: the meaning of the signal depends on the system. FALSE: the meaning of the signal depends on the system.
Demand	Outputs the safety related response of the function. FALSE: Demand for safety related response, request for safe state. TRUE: No demand for safety related response, request for operational state.
Activate	This parameter is used to activate the function. Connect will set this value to true when an MSF is selected. TRUE: function will be executed. FALSE: function is deactivated.

## 8.24 Safe 8 AND, S8AND

This function tests its eight safe inputs for their state, applies a logical AND then sets the output accordingly. Some of the safe inputs can be disabled. Values are available to be read in Test Mode, if values are read from an activated function the current values are returned, if a read is made on a deactivated function the default value is returned (typically 0 or FALSE).

**Figure 8-69 Diagrammatic representation of the Safe 8AND function**

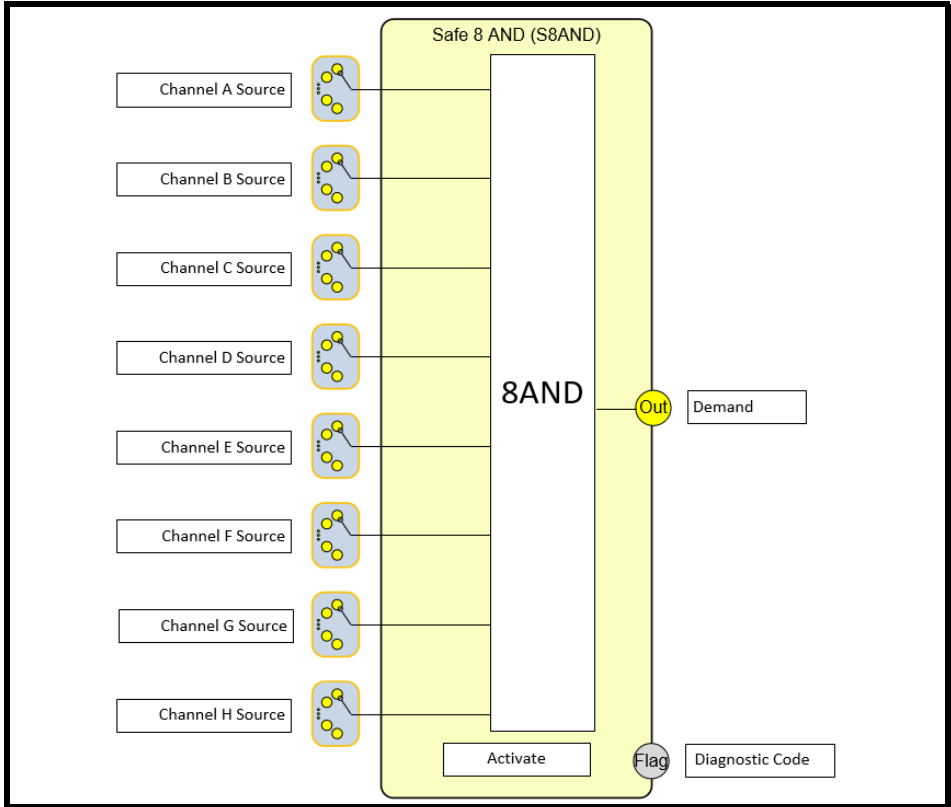

Name	Description
Channel A Source	Primary input selector that cannot be disabled. Selects the safety signal that needs to be ANDed with the value connected to other active input selectors. 0.000: Default (Illegal will cause a configuration error, this must be set by the user) <u>Value of Source Selected</u> TRUE: the meaning of the signal depends on the system. FALSE: the meaning of the signal depends on the system.
Channel B Source	Same as Above
Channel C Source	Same as Above

Name	Description
Channel D Source	Secondary input selector that can be disabled. Selects the safety signal that needs to be ANDed with the value connected to other active input selectors. 0.000: Default (Illegal will cause a configuration error, this must be set by the user) 0.001: Disabled, input selector is disabled and acts as logical TRUE <u>Value of Source Selected</u> TRUE: the meaning of the signal depends on the system FALSE: the meaning of the signal depends on the system
Channel E Source	Same as Above
Channel F Source	Same as Above
Channel G Source	Same as Above
Channel H Source	Same as Above
Demand	Outputs the safety related response of the function. Demand Out is set to TRUE only when all non-disabled inputs are also TRUE otherwise Demand Out is set to FALSE. FALSE: Demand for safety related response, request for safe state. TRUE: No demand for safety related response, request for operational state.
Activate	This parameter is used to activate the function. Connect will set this value to true when an MSF is selected. TRUE: function will be executed. FALSE: function is deactivated.
Diagnostic Code	Diagnostic Fault Code, Not Currently Used

## 8.25 Safe Boolean Hardware Inputs, SHIS

This function block reads the 4 dual channel hardware input values into 4 Read Only SAFEBOOLS that are updated once per cycle with the hardware input state before the MSFs are run. Each can be used as the value source for an input selector belonging to another function. Individual hardware inputs may be disabled at design time in which case their output values cannot be used in the configuration and they do not raise errors or alarms.

**Figure 8-70 Diagrammatic Model of Hardware Inputs**

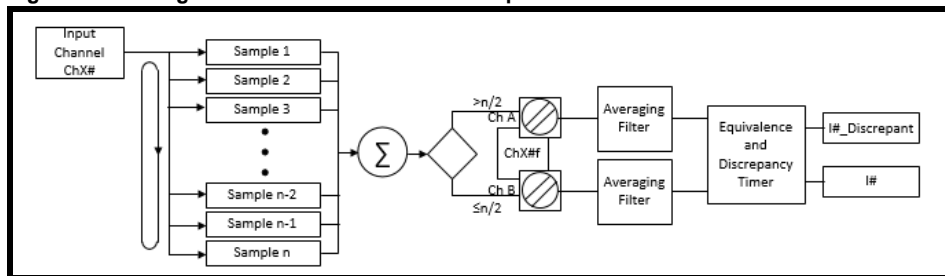

The 2 hardware input channels on each input pair are filtered using moving average filters, the values (Ch A and Ch B) after filtering are passed to the equivalence and discrepancy block and "Input Value" is evaluated for that pair.

The "Input Value" for each pair is set to FALSE if Ch A and Ch B are FALSE or discrepant. It can only be set to TRUE if Ch A and Ch B are TRUE and there is no latched discrepancy error waiting to be cleared.

The function has a Diagnostic Code for each pair and for the overall block.

If an input becomes discrepant for more than the user set time an Error is generated (set to TRUE), which triggers a System Alarm (See section 9.2) which will set all of the MiS2x0 Safety Module outputs to FALSE and stop evaluation of all Logic and Output functions. This is irrespective of the state of the rest of the configuration and is because the inputs can no longer be trusted.

The System and SHIS function will both require a reset, and a reset can only occur if all inputs are not discrepant. The SHIS function may share the system reset input. An automatic reset is where the function resets when all the Hardware Inputs go to TRUE and does not require a reset signal of any kind.

**Figure 8-71 Diagrammatic representation of the Hardware Inputs**

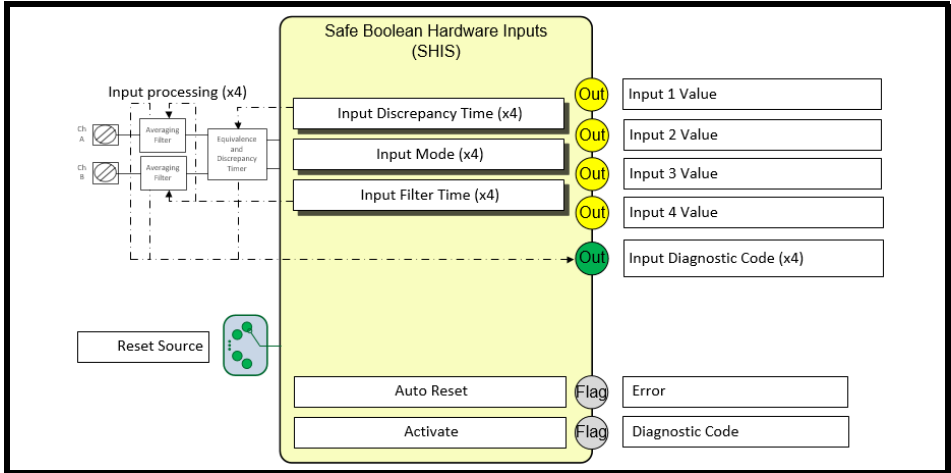

**Standards:**

BS EN 61131-2:2007

Programmable controllers

Part 2: Equipment requirements and tests

**Number of Instances: 1**

Name	Description
Input 1 Value	Boolean value representing the state of the Input Pair 1 after filtering and discrepancy timing has been processed. TRUE: if and only if both channels of the input after filtering are in the true. FALSE: if either input channel is false.
Input 2 Value	Boolean value representing the state of the Input Pair 2 after filtering and discrepancy timing has been processed. TRUE: if and only if both channels of the input after filtering are in the true. FALSE: if either input channel is false.
Input 3 Value	Boolean value representing the state of the Input Pair 3 after filtering and discrepancy timing has been processed. TRUE: if and only if both channels of the input after filtering are in the true. FALSE: if either input channel is false.
Input 4 Value	Boolean value representing the state of the Input Pair 4 after filtering and discrepancy timing has been processed. TRUE: if and only if both channels of the input after filtering are in the true. FALSE: if either input channel is false.

Name	Description	Information
Reset Source	Value that will provide the reset source, typically it will be System Reset but may be connected to any input to control the Reset. 0.001: Disabled, the Auto Reset attribute must be set to on. 0.002: Default, indicating that the function reset should share the System Reset input Numeric ID: From a Non-Safe Boolean Input (BIS) or from a SAFEBOOL if it is also connected to another Safe Output. <u>Value of Source Selected</u> Rising Edge (a change from FALSE to TRUE): The function will be reset if the error condition is no longer present Falling edge or unchanging TRUE or FALSE: No effect	Introduction
Input 1 Discrepancy Time	Maximum discrepancy time in ms that an input pair is allowed to be discrepant before the input is regarded as faulty and an input error is raised. The discrepancy time extends the response time of the safety module.	Technical Safety Features
Input 2 Discrepancy Time	Same as Above	Installation
Input 3 Discrepancy Time	Same as Above	Connect Configuration Tool Introduction
Input 4 Discrepancy Time	Same as Above	Start Up
Input 1 Mode	Mode of the dual channel input Disabled (0): The 2 input channels are marked as not used and the output must not be physically connected. ExternalContPS (1): The 2 input channels must be sourced from a continuous 24 V power supply they will only be checked for faults internal to the MiS2x0 Safety Module. InternalPulsedPS (2): The 2 input channels must be wired to the pulsed output terminal; the pulses will then appear on the input terminals and so both internal and external circuit can be checked for faults. OSSD (3): Compatible with safety devices that for test purposes produce notched outputs with OSSD timings. The input will ignore notches. In this mode the 2 input channels can only be checked for faults internal to the MiS2x0 Safety Module.	Validation
Input 2 Mode	Same as Above	Motion Safety Function Details
Input 3 Mode	Same as Above	
Input 4 Mode	Same as Above	
Input 1 Filter Time	To provide filtering of residual test pulses present on the input lines when driven by an external source (OSSD mode). The safe inputs are fitted with a configurable sliding window filter. The Filter Time represent the size of the filter window and can be set in 1 ms increments. Interference pulses whose time is under half of the filter window will be filtered out by the filter and thus ignored by the inputs. It is important to note that any delay to the response time introduced by the input filter should be added to the system response time. To calculate the additional delay, divide the filter window time by two and round to the highest millisecond. Minimum Value is 8 which is equivalent to 1 ms.	
Input 2 Filter Time	Same as Above	Key Safety Data
Input 3 Filter Time	Same as Above	
Input 4 Filter Time	Same as Above	
Auto Reset	Reset behaviour after the System Start OFF: No special reset behaviour (reset signal is always required) ON: No reset is required to exit a discrepancy error (automatic reset will be applied) A risk assessment on the system must take place and justification provided in the system documentation before this feature is used.	
Input 1 Diagnostic Code	Hardware Diagnostic Value for the Input Pair	
Input 2 Diagnostic Code	Same as Above	

Name	Description
Input 3 Diagnostic Code	Same as Above
Input 4 Diagnostic Code	Same as Above
Error	Indicates that the function has detected an error condition. TRUE: Error, an enabled input has been discrepant for more than the allowed time, check Diagnostic Codes FALSE: No Error.
Diagnostic Code	Diagnostic Fault Code, visible in Connect in Test Mode (see separate table)
Activate	This parameter is used to activate the function. Connect will set this value to true when an MSF is selected. TRUE: function will be executed. FALSE: function is deactivated.

Figure 8-72 State Machines with and without Auto Reset

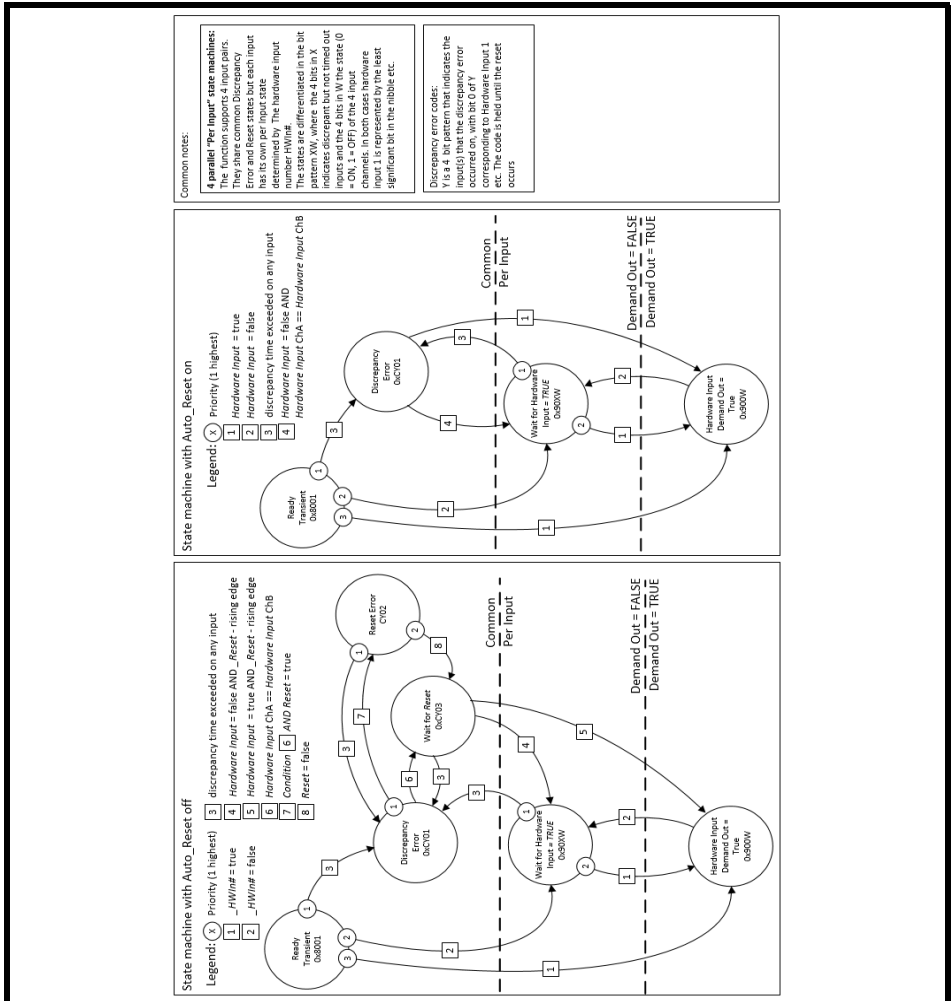
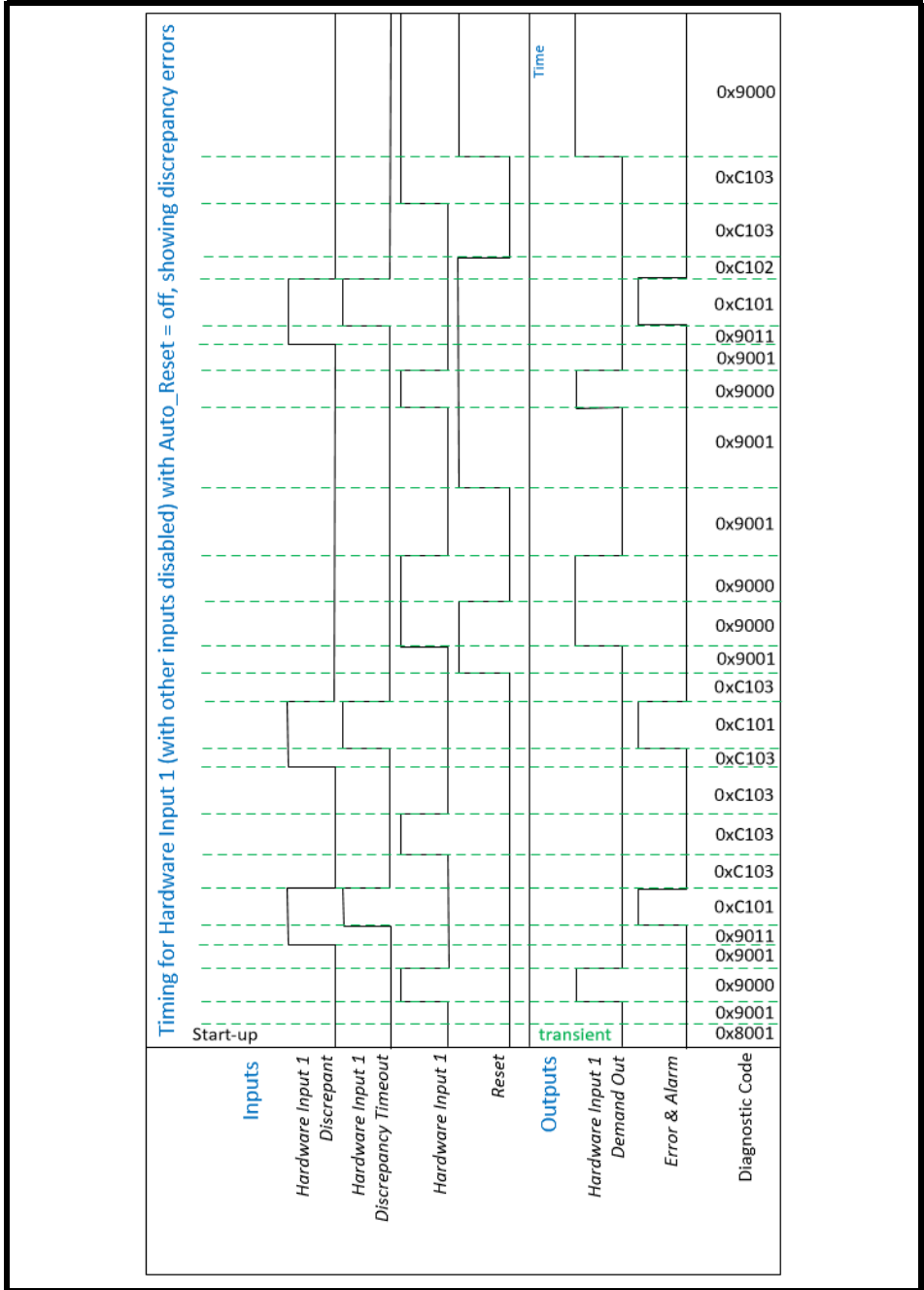

Figure 8-73 Timing Diagram for input 1 (all other inputs disabled) with Auto Reset OFF, showing 3 discrepancy errors



Information	Introduction	Technical Safety Features	Installation	Connect Configuration Tool Introduction	Start Up	Validation	<b>Motion Safety Function Details</b>	Diagnostics and Maintenance	Key Safety Data	Version Control (Amendments)
-------------	--------------	---------------------------	--------------	---	----------	------------	---------------------------------------	-----------------------------	-----------------	------------------------------



Bit	Code used in diagrams	Description
0	W	INPUT PAIR 1 - 0 if channel A and channel B are both ON otherwise 1
1		INPUT PAIR 2 - 0 if channel A and channel B are both ON otherwise 1
2		INPUT PAIR 3 - 0 if channel A and channel B are both ON otherwise 1
3		INPUT PAIR 4 - 0 if channel A and channel B are both ON otherwise 1
4	X	INPUT PAIR 1 - 1 if is discrepant but not timed out, otherwise 0
5		INPUT PAIR 2 - 1 if is discrepant but not timed out, otherwise 0
6		INPUT PAIR 3 - 1 if is discrepant but not timed out, otherwise 0
7		INPUT PAIR 4 - 1 if is discrepant but not timed out, otherwise 0
8	Y	INPUT PAIR 1 - caused the last discrepancy error
9		INPUT PAIR 2 - caused the last discrepancy error
10		INPUT PAIR 3 - caused the last discrepancy error
11		INPUT PAIR 4 - caused the last discrepancy error

**NOTE**

Discrepancy errors from state 0x8001 should only occur if the discrepancy time is set to zero and the input channels are discrepant at start up, these transitions are not shown in the timing diagrams.

ERRORS THAT CAN TRIGGER ALARMS - ALL SAFE OUTPUTS GO SAFE		
Code	State	Description
0xCY01	Discrepancy Error	One or more of the inputs (indicated by bits in Y) has been discrepant for longer than its allowed time. In this state: "Input Value" = FALSE, "Error" = TRUE
0xCY02	Reset Error	When the CY01 state cleared the reset input was high, so the reset rising edge cannot be detected and the function cannot be reset. In this state: "Input Value" = FALSE, "Error" = TRUE, "SHIS State" = variable
0xCY03	Wait for Reset Rising Edge	Wait for "Reset" to go to TRUE, state then transitions to one of 0xCY01, 0x90XW or 0x900W. In this state: "Input Value" = FALSE, "Error" = FALSE
DIAGNOSTIC ERRORS – Information for the User		
0x8001	Ready	Transient state on start-up function the state transitions to one of 0xCY01, 0x90XW or 0x900W depending on state of "Hardware Input" and "Start Reset". In this state: "Input Value" = FALSE, "Error" = FALSE
0x90XW	Hardware Input Demand Output = FALSE	"Hardware Input" is FALSE and a reset has occurred (if required). W indicates the output bit states. X indicates inputs that are discrepant but not timed out. In this state: "Input Value" = TRUE, "Error" = FALSE
0x900W	Hardware Input Demand Output = TRUE	"Hardware Input" is TRUE and a reset has occurred (if required). W indicates the output bit states. In this state: "Input Value" = TRUE, "Error" = FALSE

Individual Pair Diagnostic Codes

Hardware Input	Description
0x00800004	Input Channel A = 1 and Input Channel B = 1
0x00800104	Input Channel A = 0 and Input Channel B = 0
0x00800404	Input Channel A & B = 1 and previously were discrepant
0x00800604	Input Channel A & B = 0 or 1 and previously were OK
0x00801404	Input Channel A & B = 0 and Previously were discrepant
0x00C00104	Input Channel A & B = discrepant and discrepancy counter expired
0x00810004	Valid On State, A & B Toggling and in Synch
0x00810104	Valid Off State, A & B are Equal
0x00810204	Both Input Channels Open (Not Toggling) but in same state
0x00810404	Discrepant with Input Channel A Closed (Toggling) & Input Channel B = Open (Not Toggling)
0x00810604	Discrepant with Input Channel A Open (Not Toggling) & Input Channel B = Closed (Toggling)
0x00810804	Invalid, Both Inputs Open (Not Toggling) but the state is reversed
0x00811404	A Toggling, B Unexpected State or B Toggling, A Unexpected State
0x00811604	Input Channel A & Input Channel B Toggling but are Opposite
0x00C10104	Discrepancy Counter Expired

## 8.26 Safe Torque Off, STO



This function controls the blade connector that interfaces directly with the Certified Safe Torque Off (STO) circuitry in the drive. It is the safety engineer's responsibility to check that the drive supports the blade connector.

**WARNING**

If supported by the drive, this function when triggered by the Command Source going FALSE causes the drive to disable its power output so that the motor and load will exhibit whatever behavior is dictated by the load torque. The hardware STO circuitry in the host drive will respond by preventing the connected motor from producing any significant torque after a delay of no less than 1 ms and no greater than 20 ms. The status of this function is reported in "STO Status" and can be used to pass out the value to the Safety Network.

This function also has a Force to Safe (FTS) input that can be disabled in which case it has no effect but if it is used it works as follows:

Hardware STO Demand is set to FALSE when "Command Source" is FALSE OR "FTS Source" is FALSE

Hardware STO Demand is set to TRUE when "Command Source" is TRUE AND "FTS Source" is TRUE

### NOTE

The STO function alone does not support the reset functionality required by standards such as: IEC 418: 1992, IEC 954-1: 1996, ISO 12100-2: 2003, IEC 60204-1, 1997, etc. If such a machine reset is required, then either it must be handled externally to the safety module or a safety module function such as SES (which provides such a reset) should be used to control the STO function.

**Figure 8-75 Diagrammatic representation of the STO function**

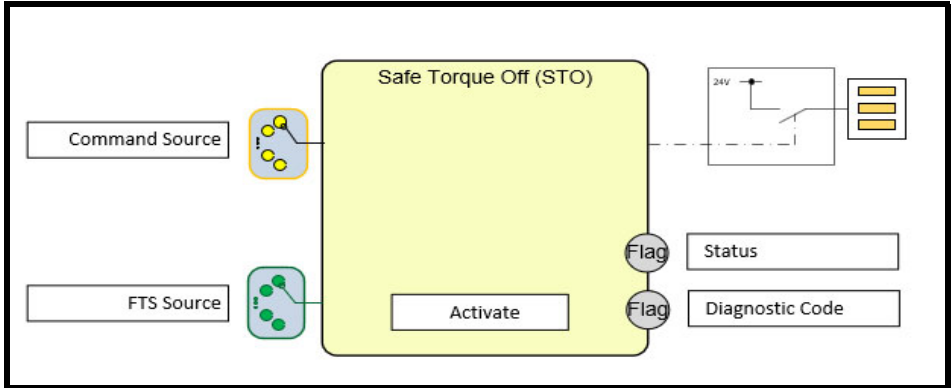

**Standards:**

- IEC 61800-5-2
- 4.2.2.2 Safe torque off (STO)
- 6. Requirements for design and development of a PDS(SR) (SIL level).
- IEC 60204-1
- 3.56 Uncontrolled Stop.
- 9.2.2 Stop functions (stop category 0).
- ISO 13849-1
- PL level.
- IEC 62061: 2005
- 6. Design and integration of the safety-related electrical control system (SRECS).
- IEC 61508
- General design standard for Functional Safety.

**Number of Instances: 1**

Name	Description
Command Source	Value that will provide the safety control signal (Ctrl in the State Machine) for the STO. This will typically be the output parameter of a function such as SES or SLS. Alternatively, it can be connected directly to an input function which in turn connects to a hard-wired input pair or network input (this allows the STO to be controlled directly by another safety device). Numeric ID: for a valid Output Connector from another block <u>Value of Source Selected</u> TRUE: No demand for safe torque off, operational state FALSE: Demand for safe torque off (e.g. emergency stop has been engaged etc.).
FTS Source	Value that can set the STO to FALSE but only set it to TRUE if "Command Source" is also TRUE. (Force to Safe - FTS). 0.001: Default, disables the input Numeric ID: for a valid Output Connector from another block <u>Value of Source Selected</u> TRUE: A normal signal (i.e. not part of the safety system) requesting drive operational state (no safe torque off) this signal cannot override the "Command Source" signal. FALSE: A normal signal (i.e. not part of the safety system) demanding safe torque off).
Status	Notification of the STO hardware status for mapping to a Network Output TRUE: No demand for safe torque off FALSE: Safe Torque Off ACTIVATED
Diagnostic Code	Diagnostic Fault Code, visible in Connect in Test Mode (see separate table)
Activate	This parameter is used to activate the function. Connect will set this value to true when an MSF is selected. TRUE: function will be executed. FALSE: function is deactivated.

Information
Introduction
Technical Safety Features
Installation
Connect Configuration Tool Introduction
Start Up
Validation
<b>Motion Safety Function Details</b>
Diagnostics and Maintenance
Key Safety Data
Version Control (Amendments)

**Figure 8-76 State Machine**

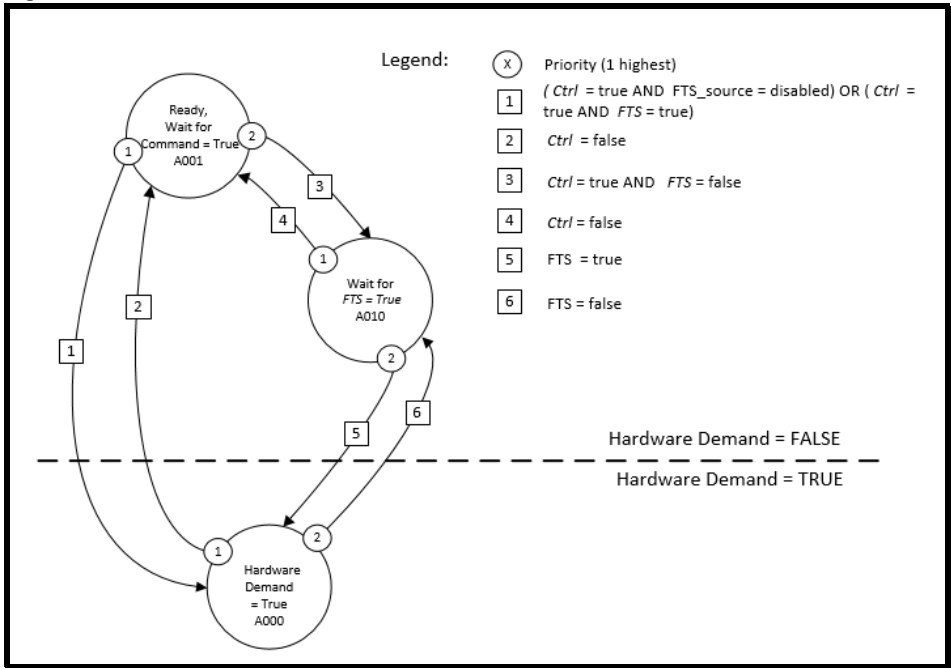



## DIAGNOSTIC ERRORS - Information for the User

Code	State	Description
0xA011	Initialise	Transient (1 ms) at start up only.
0xA001	Ready, Wait for "Command Source"	The input connected to "Command Source" is FALSE. Drive STO circuitry prevents the motor from producing torque. In this state: "STO Status" = FALSE, Hardware STO Demand = 0
0xA010	Wait for "FTS Source"	Wait for FTS to go to TRUE. Drive STO circuitry prevents the motor from producing torque. In this state: "STO Status" = FALSE, Hardware STO Demand = 0
0xA000	Hardware Demand = True	The input connected to "Command Source" is TRUE and the FTS is also TRUE. Drive STO circuitry allows the motor to produce torque. In this state: "STO Status" = TRUE, Hardware STO Demand = 1

### 8.27 Safe Boolean Hardware Outputs, SHOS

This function controls the two SAFEBOOL hardware outputs fitted to the MiS2x0 Safety Module. It does not have a SAFEBOOL output connection as the function acts directly on the hardware outputs, a selected input value of FALSE will cause the hardware output into its low state. The hardware circuitry in the safety module will respond setting the output to its low state after a delay of no more than 1 ms. While a value of TRUE will give the high state. Individual hardware outputs may be disabled by setting the selector to disabled. The status of this function is reported with "SO1 Status" and "SO2 Status" and they can be used to pass out the values to the Safety Network.

This function also has a Force to Safe (FTS) input for each Safe Output that can be disabled in which case it has no effect but if it is used it works as follows:

Hardware Output Demand is set to FALSE when "Output Command Source" is FALSE OR "FTS Source" is FALSE

Hardware Output Demand is set to TRUE when "Output Command Source" is TRUE AND "FTS Source" is TRUE

This function has no error state and no reset.

#### NOTE

This function alone does not support the reset functionality required by standards such as: IEC 418: 1992, IEC 954-1: 1996, ISO 12100-2: 2003, IEC 60204-1, 1997, etc. If such a machine reset is required, then either it must be handled externally to the safety module or a safety module function such as SES (which provides such a reset) should be used to control the SHOS function.

**Figure 8-78 Diagrammatic representation of the Hardware Outputs**

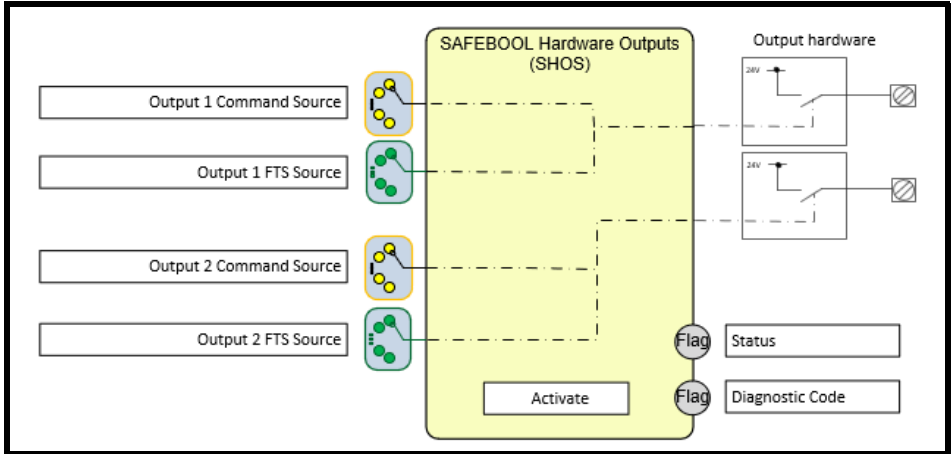

**Standards:**

- IEC 61131-2:2007 Programmable controllers. Part 2: Equipment requirements and tests.
- IEC 61800-5-2 4.2.2.2 Safe torque off (STO)
- 6. Requirements for design and development of a PDS(SR) (SIL level).
- IEC 60204-1 3.56 Uncontrolled Stop.
- 9.2.2 Stop functions (stop category 0).
- ISO 13849-1 PL level.
- IEC 62061: 2005 6. Design and integration of the safety-related electrical control system (SRECS).
- IEC 61508 General design standard for Functional Safety.

**Number of Instances: 1**

Name	Description
Output 1 Command Source	Selects the value that will provide the safety control signal for Hardware Output 1. This will typically be the output of a function. Alternatively, it can be connected directly to an input function value parameter which in turn connects to a hard-wired input pair or network input (this allows the output to be controlled directly by another safety device). Numeric ID: for a valid Output Connector from another block <u>Value of Source Selected</u> TRUE: No demand for safe state (HIGH). FALSE: Demand for safe state (LOW).
Output 2 Command Source	Same as Above but for Hardware Output 2

Name	Description
Output 1 FTS Source	Value that can set the Hardware Output 1 to FALSE but only set it to TRUE if "Output 1 Command Source" is also TRUE. (Force to Safe - FTS). 0.001: Default, disables the input Numeric ID: for a valid Output Connector from another block <u>Value of Source Selected</u> TRUE: A normal signal (i.e. not part of the safety system) requesting drive operational state (no safe torque off) this signal cannot override the "Output 1 Command Source" signal. FALSE: A normal signal (i.e. not part of the safety system) demanding safe torque off).
Output 2 FTS Source	Same as Above but for Hardware Output 2
SO1 Status	Notification of the Hardware Output 1 status for mapping to a Network Output TRUE: No demand for safe state FALSE: Safe State DEMANDED
SO2 Status	Same as above but for Hardware Output 2
Diagnostic Code	Diagnostic Fault Code, visible in Connect in Test Mode (see separate table)
Activate	This parameter is used to activate the function. Connect will set this value to true when an MSF is selected. TRUE: function will be executed. FALSE: function is deactivated.

**Figure 8-79 State Machines, represents 2 state machines, one for each output with the Ready state common to both**

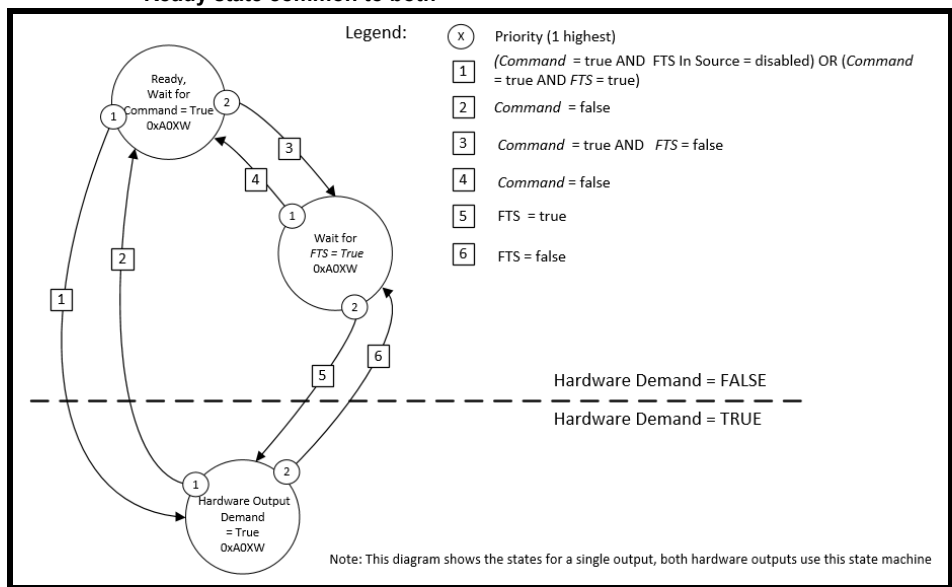
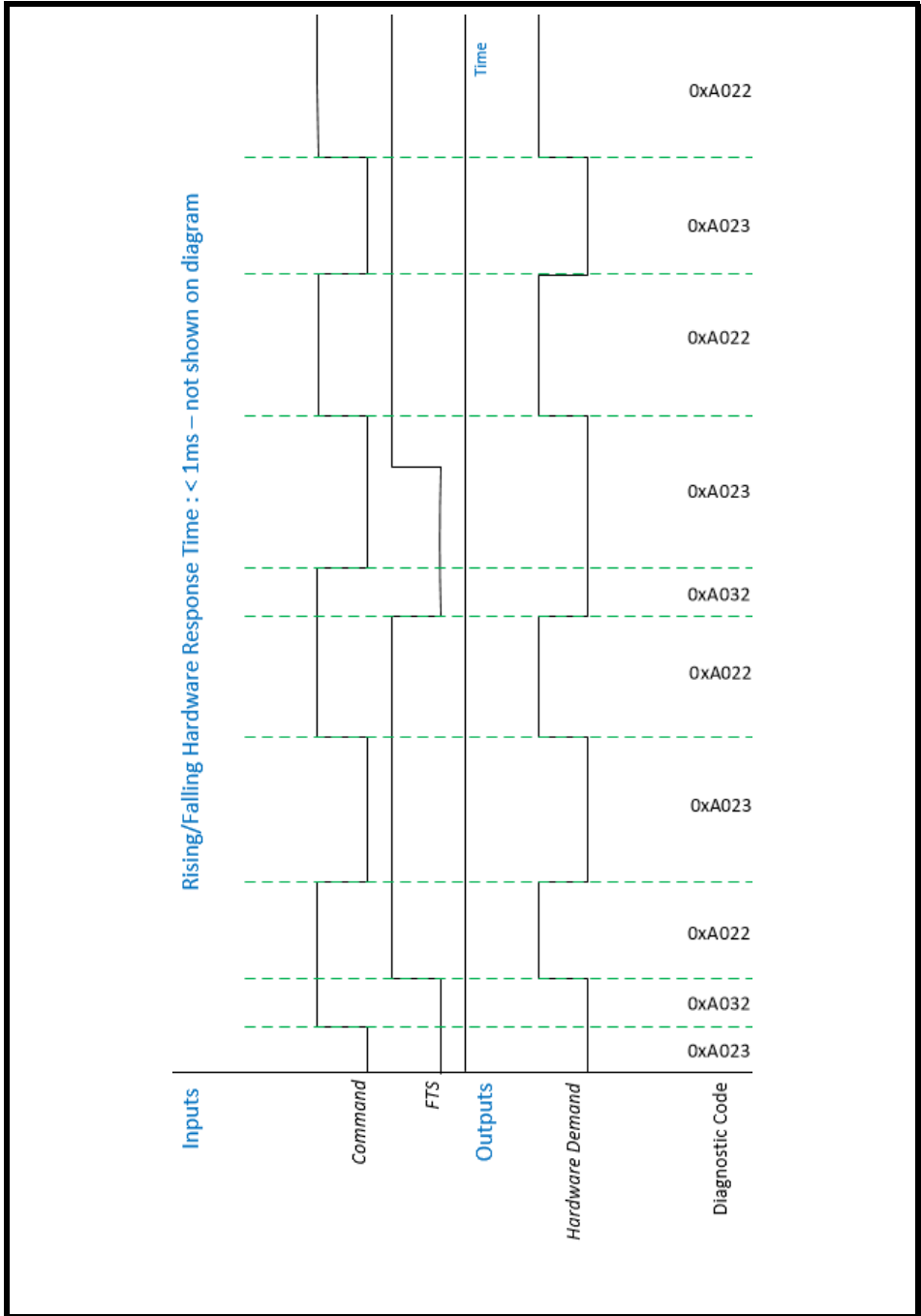

Figure 8-80 Timing Diagram for Output 1 (all other outputs disabled)



Information
Introduction
Technical Safety Features
Installation
Connect Configuration Tool Introduction
Start Up
Validation
<b>Motion Safety Function Details</b>
Diagnostics and Maintenance
Key Safety Data
Version Control (Amendments)

Bit	Code used in diagrams	Description
0	W	OUTPUT 1 - 0 if ON (TRUE)
1		OUTPUT 2 - 0 if ON (TRUE)
2		Not Used
3		Not Used
4	X	OUTPUT 1 - if Forced to Safe
5		OUTPUT 2 - if Forced to Safe
6		Not Used
7		Not Used

DIAGNOSTIC ERRORS - Information for the User		
Code	State	Description
0xA0XW	Ready, Wait for Hardware Output Command Source	The input connected to "Output Command Source" is FALSE. In this state: Hardware Output = 0 and SO Status = FALSE
0xA0XW	Wait for FTS	Wait for FTS to go to TRUE. X indicates the outputs in this state. In this state: Hardware Output = 0 and SO Status = FALSE
0xA0XW	Hardware Output = True	"Output Command Source" is TRUE and FTS is TRUE W indicates the output bit states. In this state: Hardware Output = 1 and SO Status = TRUE

### Examples of the Diagnostics.

Looking at a configuration that is just using Output 1:

State	Hex Diagnostic	Bit7	Bit6	Bit5	Bit4	Bit3	Bit2	Bit1	Bit0
Init (not shown)	0xA011	0	0	0	1	0	0	0	1
Ready	0xA001	0	0	0	0	0	0	0	1
Wait For FTS	0xA010	0	0	0	1	0	0	0	0
Output On	0xA000	0	0	0	0	0	0	0	0

Looking at a configuration that is just using Output 2:

State	Hex Diagnostic	Bit7	Bit6	Bit5	Bit4	Bit3	Bit2	Bit1	Bit0
Init (not shown)	0xA022	0	0	1	0	0	0	1	0
Ready	0xA002	0	0	0	0	0	0	1	0
Wait For FTS	0xA020	0	0	1	0	0	0	0	0
Output On	0xA000	0	0	0	0	0	0	0	0

## 8.28 Safe Boolean Network Inputs, SNIS

Each instance represents a set of 4 SAFEBOOL inputs transmitted over a safety network to the MiS2x0 Safety Module, and the MiS2x0 Safety Module can handle up to 32 bits. A mode attribute allows individual bits to be turned on and off, this is represented in Connect by the drop-down box for a bit saying unassigned.

Network configuration is done globally via Connect and there are no attributes related to the network setup in this function.

Network Diagnostics are output to the MiS2x0 Safety Module menu.

**Figure 8-81 Diagrammatic representation of the Network Boolean Inputs**

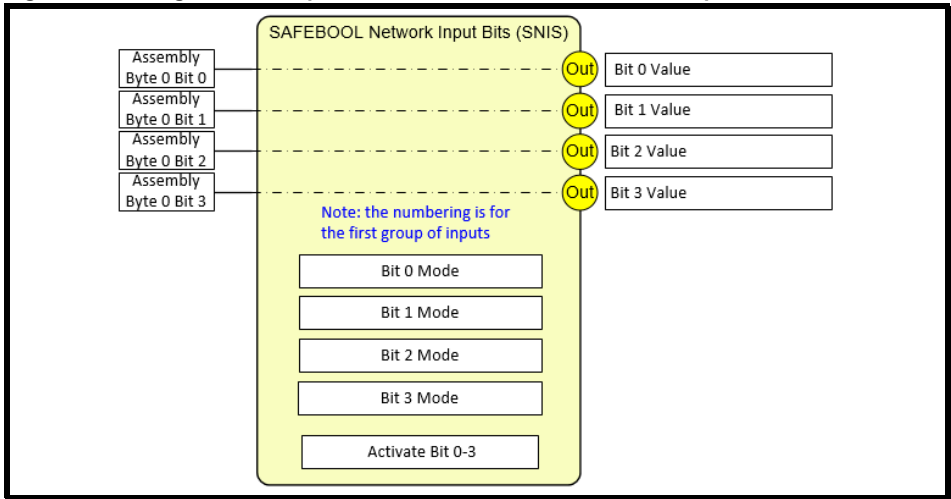

**Number of Instances: 8**

Instance 1 - Bits 0-3

Instance 2 - Bits 4-7

Instance 3 - Bits 8-11

Instance 4 - Bits 12-15

Instance 5 - Bits 16-19

Instance 6 - Bits 20-33

Instance 7 - Bits 24-27

Instance 8 - Bits 28-31

The data from the PLC is an array of bytes (8bits) and the boolean data is interleaved with the integer data if it is being used.

8 bits of Boolean Data (SNIS 1 &amp; SNIS 2)

32 bits of Integer Data (SINIS Integer 1)

8 bits of Boolean Data (SNIS 3 &amp; SNIS 4)

32 bits of Integer Data (SINIS Integer 2)

See section 8-30 for a diagram showing this.

Name	Description
Bit 0 Value	For instance 1, Network Byte = 0 of which bit 0 maps to parameter 021 For instance 2, Network Byte = 0 of which bit 4 maps to parameter 121 For instance 3, Network Byte = 5 of which bit 0 maps to parameter 221 For instance 4, Network Byte = 5 of which bit 4 maps to parameter 321 For instance 5, Network Byte = 10 of which bit 0 maps to parameter 421 For instance 6, Network Byte = 10 of which bit 4 maps to parameter 521 For instance 7, Network Byte = 15 of which bit 0 maps to parameter 621 For instance 8, Network Byte = 15 of which bit 4 maps to parameter 721
Bit 1 Value	For instance 1, Network Byte = 0 of which bit 1 maps to parameter 022 For instance 2, Network Byte = 0 of which bit 5 maps to parameter 122 For instance 3, Network Byte = 5 of which bit 1 maps to parameter 222 For instance 4, Network Byte = 5 of which bit 5 maps to parameter 322. For instance 5, Network Byte = 10 of which bit 1 maps to parameter 422 For instance 6, Network Byte = 10 of which bit 5 maps to parameter 522 For instance 7, Network Byte = 15 of which bit 1 maps to parameter 622 For instance 8, Network Byte = 15 of which bit 5 maps to parameter 722
Bit 3 Value	For instance 1, Network Byte = 0 of which bit 2 maps to parameter 023 For instance 2, Network Byte = 0 of which bit 6 maps to parameter 123 For instance 3, Network Byte = 5 of which bit 2 maps to parameter 223 For instance 4, Network Byte = 5 of which bit 6 maps to parameter 323 For instance 5, Network Byte = 10 of which bit 2 maps to parameter 423 For instance 6, Network Byte = 10 of which bit 6 maps to parameter 523 For instance 7, Network Byte = 15 of which bit 2 maps to parameter 623 For instance 8, Network Byte = 15 of which bit 6 maps to parameter 723
Bit 0 Mode	Mode of the Network input bit (this allows individual bits to be disabled – but they may still be passed in by the network). 0: Disabled – the input bit is not in use and is held false. 1: Enabled – the input bit is in use and follows the network bit.
Bit 1 Mode	Same as Above
Bit 2 Mode	Same as Above
Bit 3 Mode	Same as Above
Activate Bit 0-3	This parameter is used to activate the function. Connect will set this value to true when an MSF is selected. TRUE: function will be executed. FALSE: function is deactivated.

## 8.29 Safe Boolean Network Outputs, SNOS

Each instance of this function block represents a set of 4 SAFEBOOL outputs to be transmitted over a safety network from the MiS2x0 Safety Module, and the MiS2x0 Safety Module can handle up to 32 bits. Individual bits can be enabled or disabled; this is represented in Connect by the drop-down box for a bit saying unassigned.

Network configuration is done globally via Connect and there are no attributes related to the network setup in this function.

Network Diagnostics are output to the MiS2x0 Safety Module menu.

This function also has a Force to Safe (FTS) input that can be disabled in which case it has no effect but if it is used it works as follows:

Network Output is set to FALSE when "Command Source" is FALSE OR "FTS Source" is FALSE

Network Output is set to TRUE when "Command Source" is TRUE AND "FTS Source" is TRUE

**Figure 8-82 Diagrammatic representation of the Network Boolean Outputs**

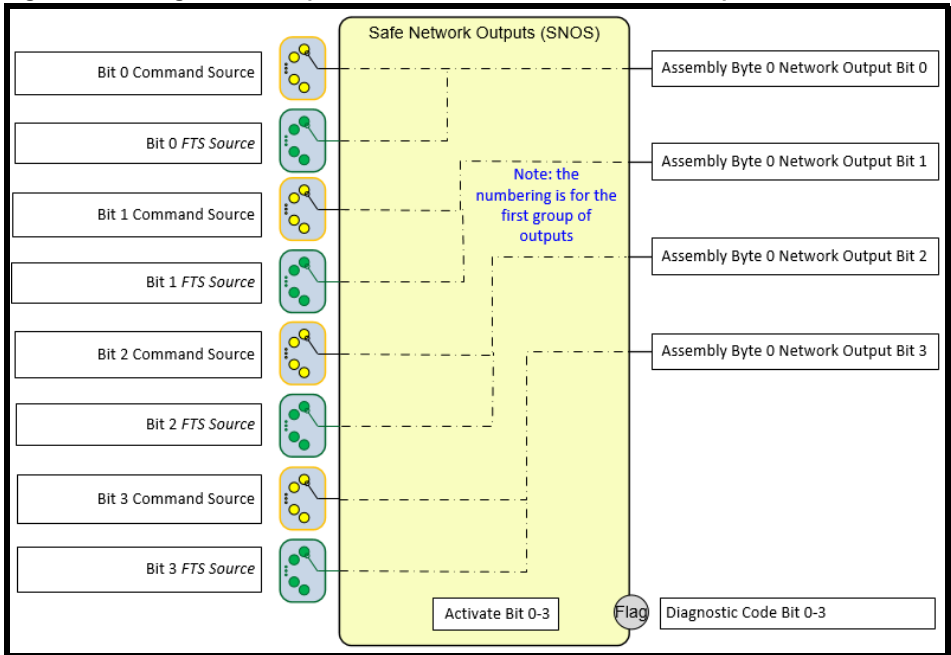

**Number of Instances: 8**

Instance 1 - Bits 0-3

Instance 2 - Bits 4-7

Instance 3 - Bits 8-11

Instance 4 - Bits 12-15

Instance 5 - Bits 16-19

Instance 6 - Bits 20-23

Instance 7 - Bits 24-27

Instance 8 - Bits 28-31

The data to the PLC is an array of bytes (8bits) and the boolean data is interleaved with the integer

data if it is being used.  
 8 bits of Boolean Data  
 32 bits of Integer Data  
 Etc.

Name	Description
Bit 0 Command Source	For instance 1, the value selected by parameter 001 goes to Network Byte 0 bit 0 For instance 2, the value selected by parameter 101 goes to Network Byte 0 bit 4 For instance 3, the value selected by parameter 201 goes to Network Byte 5 bit 0 For instance 4, the value selected by parameter 301 goes to Network Byte 5 bit 4 For instance 5, the value selected by parameter 401 goes to Network Byte 10 bit 0 For instance 6, the value selected by parameter 501 goes to Network Byte 10 bit 4 For instance 7, the value selected by parameter 601 goes to Network Byte 15 bit 0 For instance 8, the value selected by parameter 701 goes to Network Byte 15 bit 4 0.000: Default, not allowed in a finished configuration. Numeric ID: for a valid Output Connector from another block <u>Value of Source Selected</u> TRUE: No demand for safe state (HIGH) FALSE: Demand for safe state (LOW)
Bit 1 Command Source	For instance 1, the value selected by parameter 002 goes to Network Byte 0 bit 1 For instance 2, the value selected by parameter 102 goes to Network Byte 0 bit 5 For instance 3, the value selected by parameter 202 goes to Network Byte 5 bit 1 For instance 4, the value selected by parameter 302 goes to Network Byte 5 bit 5 For instance 5, the value selected by parameter 402 goes to Network Byte 10 bit 1 For instance 6, the value selected by parameter 502 goes to Network Byte 10 bit 5 For instance 7, the value selected by parameter 602 goes to Network Byte 15 bit 1 For instance 8, the value selected by parameter 702 goes to Network Byte 15 bit 5 0.000: Default, not allowed in a finished configuration. Numeric ID: for a valid Output Connector from another block <u>Value of Source Selected</u> TRUE: No demand for safe state (HIGH) FALSE: Demand for safe state (LOW)
Bit 2 Command Source	For instance 1, the value selected by parameter 003 goes to Network Byte 0 bit 2 For instance 2, the value selected by parameter 103 goes to Network Byte 0 bit 6 For instance 3, the value selected by parameter 203 goes to Network Byte 5 bit 2 For instance 4, the value selected by parameter 303 goes to Network Byte 5 bit 6 For instance 5, the value selected by parameter 403 goes to Network Byte 10 bit 2 For instance 6, the value selected by parameter 503 goes to Network Byte 10 bit 6 For instance 7, the value selected by parameter 603 goes to Network Byte 15 bit 2 For instance 8, the value selected by parameter 703 goes to Network Byte 15 bit 6 0.000: Default, not allowed in a finished configuration. Numeric ID: for a valid Output Connector from another block <u>Value of Source Selected</u> TRUE: No demand for safe state (HIGH) FALSE: Demand for safe state (LOW)
Bit 3 Command Source	For instance 1, the value selected by parameter 004 goes to Network Byte 0 bit 3 For instance 2, the value selected by parameter 104 goes to Network Byte 0 bit 7 For instance 3, the value selected by parameter 204 goes to Network Byte 5 bit 3 For instance 4, the value selected by parameter 304 goes to Network Byte 5 bit 7 For instance 5, the value selected by parameter 404 goes to Network Byte 10 bit 3 For instance 6, the value selected by parameter 504 goes to Network Byte 10 bit 7 For instance 7, the value selected by parameter 604 goes to Network Byte 15 bit 3 For instance 8, the value selected by parameter 704 goes to Network Byte 15 bit 7 0.000: Default, not allowed in a finished configuration. Numeric ID: for a valid Output Connector from another block <u>Value of Source Selected</u> TRUE: No demand for safe state (HIGH) FALSE: Demand for safe state (LOW)

Name	Description
Bit 0 FTS Source	<p>The selector for the Boolean (1 bit) parameter that can force the output state to false. The input is normally disabled, but if in use it must select a non-safe input (BIS)</p> <p>For instance 1, the value selected by parameter 031 goes to Network Byte 0 bit 0  For instance 2, the value selected by parameter 131 goes to Network Byte 0 bit 4  For instance 3, the value selected by parameter 231 goes to Network Byte 5 bit 0  For instance 4, the value selected by parameter 331 goes to Network Byte 5 bit 4  For instance 5, the value selected by parameter 431 goes to Network Byte 10 bit 0  For instance 6, the value selected by parameter 531 goes to Network Byte 10 bit 4  For instance 7, the value selected by parameter 631 goes to Network Byte 15 bit 0  For instance 8, the value selected by parameter 731 goes to Network Byte 15 bit 4</p> <p>0.001: Disabled, default – FTS is not in use.  Numeric ID: for a Non-Safe Input (BIS)  <u>Value of Source Selected</u>  TRUE: A normal signal requesting drive operational state (no safe torque off) this signal cannot override the SNOS Ctrl signal  FALSE: A normal signal demanding output off</p>
Bit 1 FTS Source	<p>For instance 1, the value selected by parameter 032 goes to Network Byte 0 bit 1  For instance 2, the value selected by parameter 132 goes to Network Byte 0 bit 5  For instance 3, the value selected by parameter 232 goes to Network Byte 5 bit 1  For instance 4, the value selected by parameter 332 goes to Network Byte 5 bit 5  For instance 5, the value selected by parameter 432 goes to Network Byte 10 bit 1  For instance 6, the value selected by parameter 532 goes to Network Byte 10 bit 5  For instance 7, the value selected by parameter 632 goes to Network Byte 15 bit 1  For instance 8, the value selected by parameter 732 goes to Network Byte 15 bit 5</p> <p>0.001: Disabled, default – FTS is not in use.  Numeric ID: for a Non-Safe Input (BIS)  <u>Value of Source Selected</u>  TRUE: A normal signal requesting drive operational state (no safe torque off) this signal cannot override the SNOS Ctrl signal  FALSE: A normal signal demanding output off</p>
Bit 2 FTS Source	<p>For instance 1, the value selected by parameter 033 goes to Network Byte 0 bit 2  For instance 2, the value selected by parameter 133 goes to Network Byte 0 bit 6  For instance 3, the value selected by parameter 233 goes to Network Byte 5 bit 2  For instance 4, the value selected by parameter 333 goes to Network Byte 5 bit 6  For instance 5, the value selected by parameter 433 goes to Network Byte 10 bit 2  For instance 6, the value selected by parameter 533 goes to Network Byte 10 bit 6  For instance 7, the value selected by parameter 633 goes to Network Byte 15 bit 2  For instance 8, the value selected by parameter 733 goes to Network Byte 15 bit 6</p> <p>0.001: Disabled, default – FTS is not in use.  Numeric ID: for a Non-Safe Input (BIS)  <u>Value of Source Selected</u>  TRUE: A normal signal requesting drive operational state (no safe torque off) this signal cannot override the SNOS Ctrl signal  FALSE: A normal signal demanding output off</p>
Bit 3 FTS Source	<p>For instance 1, the value selected by parameter 034 goes to Network Byte 0 bit 3  For instance 2, the value selected by parameter 134 goes to Network Byte 0 bit 7  For instance 3, the value selected by parameter 234 goes to Network Byte 5 bit 3  For instance 4, the value selected by parameter 334 goes to Network Byte 5 bit 7  For instance 5, the value selected by parameter 434 goes to Network Byte 10 bit 3  For instance 6, the value selected by parameter 534 goes to Network Byte 10 bit 7  For instance 7, the value selected by parameter 634 goes to Network Byte 15 bit 3  For instance 8, the value selected by parameter 734 goes to Network Byte 15 bit 7</p> <p>0.001: Disabled, default – FTS is not in use.  Numeric ID: for a Non-Safe Input (BIS)  <u>Value of Source Selected</u>  TRUE: A normal signal requesting drive operational state (no safe torque off) this signal cannot override the SNOS Ctrl signal  FALSE: A normal signal demanding output off</p>
Diagnostic Code	Diagnostic Fault Code, visible in Connect in Test Mode (see separate table)

Information
Introduction
Technical Safety Features
Installation
Connect Configuration Tool Introduction
Start Up
Validation
Motion Safety Function Details
Diagnostics and Maintenance
Key Safety Data
Version Control (Amendments)

Name	Description
Activate	This parameter is used to activate the function. Connect will set this value to true when an MSF is selected. TRUE: function will be executed. FALSE: function is deactivated.

**Figure 8-83 State Machine, the diagram represents 4 separate state machines one for each output**

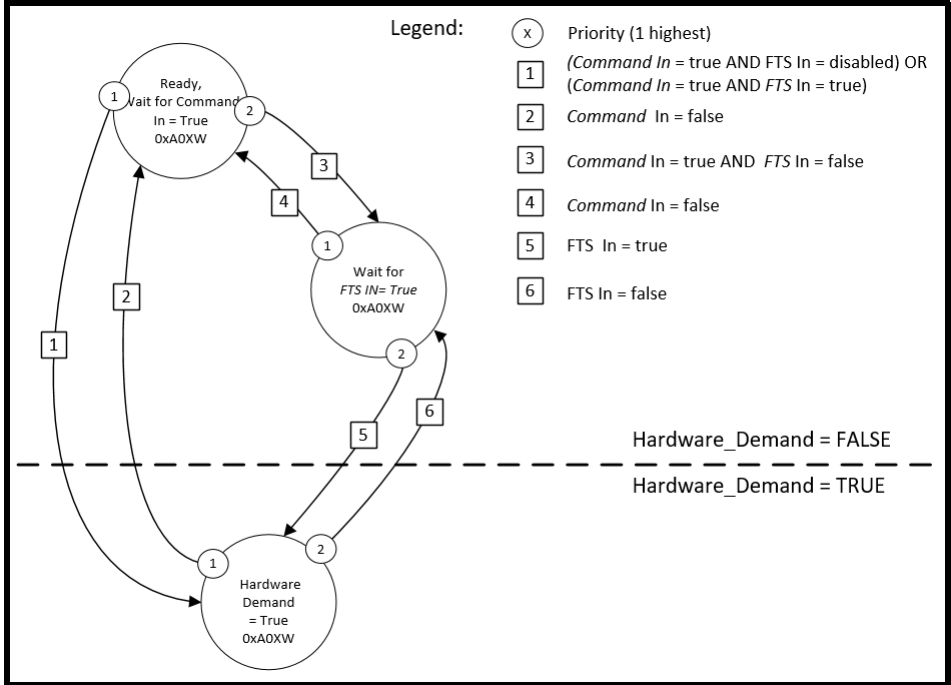

The diagnostics for each output are packed into bits, bits 0 - 3 (W in the diagrams and tables below) indicate state of the 4 output channels and bits 4 - 7 (X in the diagrams and tables below) indicate any outputs forced to safe. Outputs a to d represent a group of 4 output assembly bits.

The diagnostic codes for output a (output b to d disabled) are listed below.

Bit	Code used in diagrams	Description
0	W	1 = Output a is OFF (FALSE), 0 = Output a is ON (TRUE)
1		1 = Output b is OFF (FALSE), 0 = Output b is ON (TRUE)
2		1 = Output c is OFF (FALSE), 0 = Output c is ON (TRUE)
3		1 = Output d is OFF (FALSE), 0 = Output d is ON (TRUE)
4	X	1 = Output a is forced to SAFE, 0 = Output a is NOT forced to SAFE
5		1 = Output b is forced to SAFE, 0 = Output b is NOT forced to SAFE
6		1 = Output c is forced to SAFE, 0 = Output c is NOT forced to SAFE
7		1 = Output d is forced to SAFE, 0 = Output d is NOT forced to SAFE

DIAGNOSTIC ERRORS - Information for the User		
Code	State	Description
0xA0FF	Initialize	Transient (1 ms) at start up only
0xA0EF	Ready, Wait for Command In Source	Command Source is FALSE In this state: Network Output = FALSE
0xA0FE	Wait for FTS In Source	Wait for FTS Source to go to TRUE In this state: Network Output = FALSE
0xA0EE	Network Output = True	Command Source is TRUE, and FTS Source is TRUE W indicates the output bit states. See table above this state: Network Output = TRUE

### 8.30 Safe Integer Network Inputs, SINIS

This function block represents a set of 4 SAFEINT (32 bit) inputs transmitted over a safety network to the MiS2x0 Safety Module. Each 32 bit input can be disabled, but they can still be passed in by the network. This is done using the mode attribute and this is represented in Connect by the drop-down box for that integer saying unassigned.

Network configuration is done globally via Connect and there are no attributes related to the network setup in this function.

Figure 8-84 Diagrammatic representation of the Network Inputs

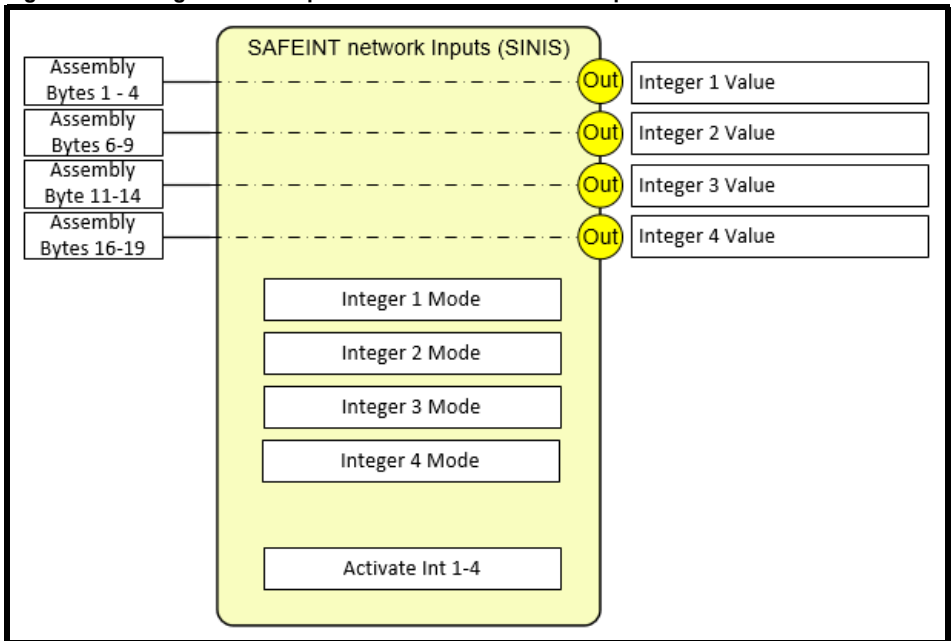

**Number of Instances: 1**

The data from the PLC is an array of bytes (8 bits) and the boolean data is interleaved with the integer data if it is being used.

8 bits of Boolean Data (SNIS 1 & SNIS 2)

32 bits of Integer Data (SINIS Integer 1)

8 bits of Boolean Data (SNIS 3 & SNIS 4)

32 bits of Integer Data (SINIS Integer 2)

This is shown in the following diagram

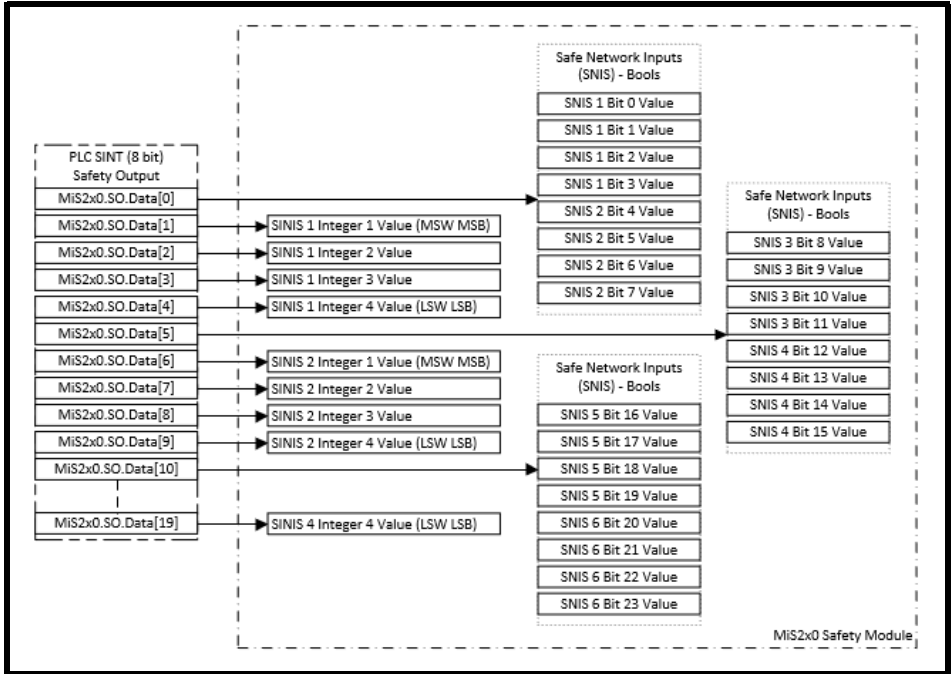

Name	Description
Integer 1 Mode	Mode of the Network input word [BIG ENDIAN] 0: Disabled – the input value is not in use and is held at 0. 1: Enabled – the input value is in use and follows the network word.
Integer 2 Mode	Mode of the Network input word [BIG ENDIAN]. 0: Disabled – the input value is not in use and is held at 0. 1: Enabled – the input value is in use and follows the network word.
Integer 3 Mode	Mode of the Network input word [BIG ENDIAN]. 0: Disabled – the input value is not in use and is held at 0. 1: Enabled – the input value is in use and follows the network word.
Integer 4 Mode	Mode of the Network input word [BIG ENDIAN]. 0: Disabled – the input value is not in use and is held at 0. 1: Enabled – the input value is in use and follows the network word.
Integer 1 Value	Bytes 1-4 to Integer 1 Value
Integer 2 Value	Bytes 6-9 to Integer 2 Value
Integer 3 Value	Bytes 11-14 to Integer 3 Value
Integer 4 Value	Bytes 16-19 to Integer 4 Value

Name	Description
Activate Int 1-4	This parameter is used to activate the function. Connect will set this value to true when an MSF is selected. TRUE: function will be executed FALSE: function is deactivated

### 8.31 Safe Integer Network Outputs, SINOS

This function block represents a set of 4 SAFEINT (32 bit) outputs to be transmitted over a safety network from the MiS2x0 Safety Module. Each 32 bit output can be disabled, this is represented in Connect by the drop down box for that integer saying disabled.

Network configuration is done globally via Connect and there are no attributes related to the network setup in this function.

**Figure 8-85 Diagrammatic representation of the Network Outputs**

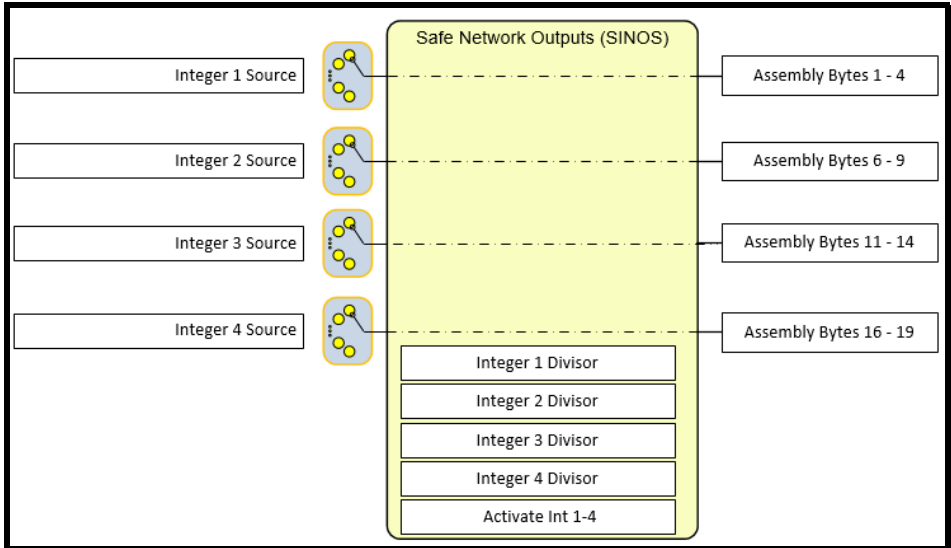

**Number of Instances: 1**

The data to the PLC is an array of bytes (8bits) and the boolean data is interleaved with the integer data if it is being used.

8bits of Boolean Data (SNOS 1 & SNOS 2)

32bits of Integer Data (SINOS Integer 1)

8bits of Boolean Data (SNOS 3 & SNOS 4)

32bits of Integer Data (SINOS Integer 2)

This is shown in the following diagram

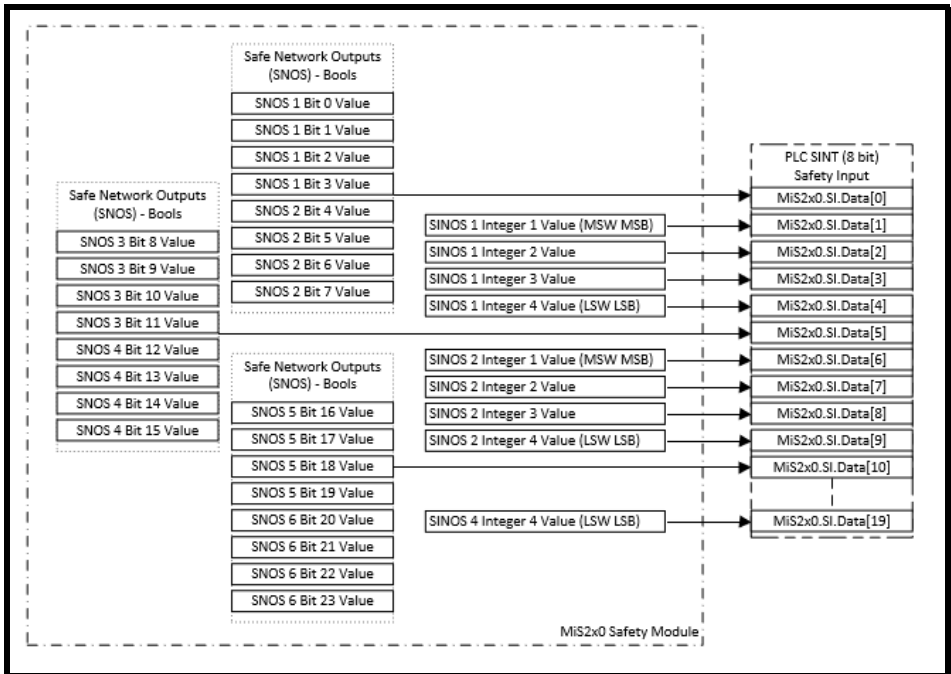

Name	Description
Integer 1 Divisor	A power of 2 divisor for Integer Output 1 to allow 64bit to be reduced to 32
Integer 2 Divisor	A power of 2 divisor for Integer Output 2 to allow 64bit to be reduced to 32
Integer 3 Divisor	A power of 2 divisor for Integer Output 3 to allow 64bit to be reduced to 32
Integer 4 Divisor	A power of 2 divisor for Integer Output 4 to allow 64bit to be reduced to 32
Integer 1 Source	INT value to be transmitted over the Safe Network. 0.001: Disabled - the default, output will be set to 0. Numeric ID: for a valid Output Connector from another block <u>Value of Source Selected</u> A 64 bit or 32 Bit safe integer. If a 64 bit integer (Position, Speed or Acceleration) is read then the divisor may be used to reduce the input to a 32 bit value this reduces the resolution of the 64 bit input value. If no divisor is used, then only the least significant 32 bits of the 64 bit input is transmitted.
Integer 2 Source	Same as Integer Source 1
Integer 3 Source	Same as Integer Source 1
Integer 4 Source	Same as Integer Source 1
Activate Int 1-4	This parameter is used to activate the function. Connect will set this value to true when an MSF is selected. TRUE: function will be executed. FALSE: function is deactivated.

**Figure 8-86 STIS-1 Diagrammatic representation of STIS**

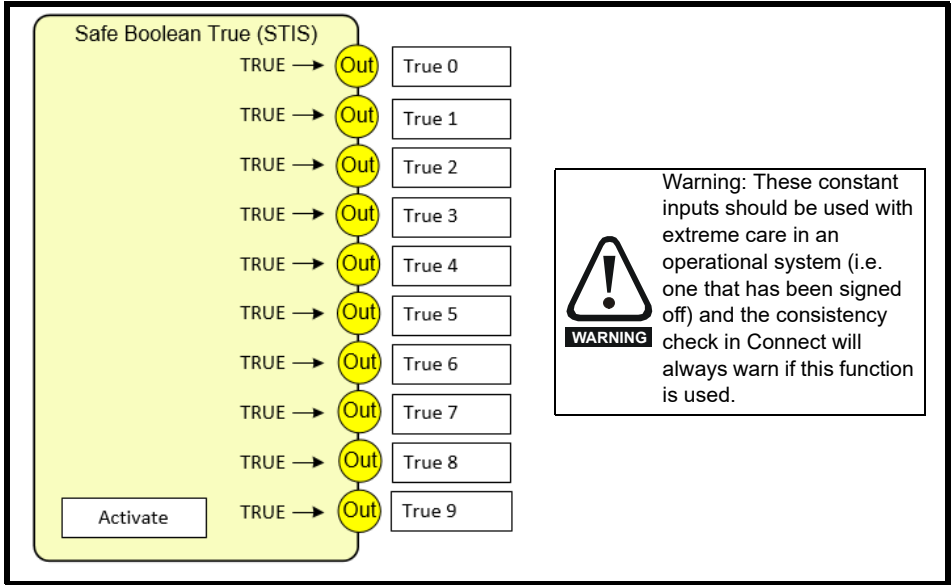

Name	Description
True 0	Always TRUE
True 1	Always TRUE
True 2	Always TRUE
True 3	Always TRUE
True 4	Always TRUE
True 5	Always TRUE
True 6	Always TRUE
True 7	Always TRUE
True 8	Always TRUE
True 9	Always TRUE
Activate	This parameter is used to activate the function. Connect will set this value to true when an MSF is selected. TRUE: function will be executed. FALSE: function is deactivated.

### 8.32 Safe FALSE, SFIS

The SFIS function has no inputs, and its 10 safe outputs are always FALSE. It is intended to be used to force SAFEBOOL function inputs or Non-Safe Inputs to FALSE for testing purposes.

Unless the whole function instance is deactivated the output connectors for the instance are always present even if the input is not used. It is not required that any of them should be connected.

**Figure 8-87 Figure SFIS-1 Diagrammatic representation of STIS**

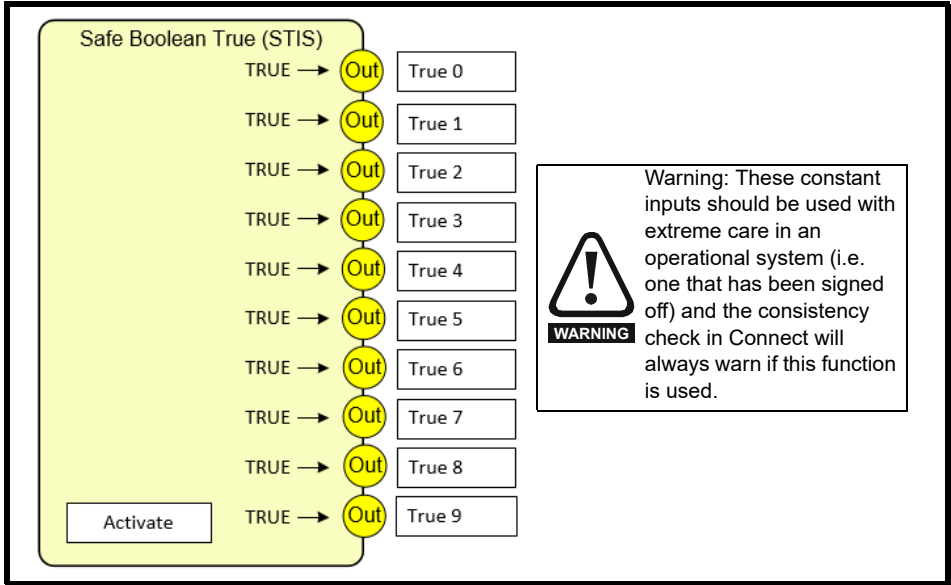

Name	Description
False 0	Always FALSE
False 1	Always FALSE
False 2	Always FALSE
False 3	Always FALSE
False 4	Always FALSE
False 5	Always FALSE
False 6	Always FALSE
False 7	Always FALSE
False 8	Always FALSE
False 9	Always FALSE
Activate	This parameter is used to activate the function. Connect will set this value to true when an MSF is selected. TRUE: function will be executed. FALSE: function is deactivated.

### 8.33 Safe Constant Integer, SCIS

The SCIS function has no inputs, and its 4 safe outputs take the integer value stored in the corresponding attribute. It is intended to be used to force SAFEINT function inputs to a given value for testing purposes.

Unless the whole function instance is deactivated the output connectors for the instance are always present even if the input is not used. It is not required that any of them should be connected.

**Figure 8-88 Diagrammatic representation of SCIS**

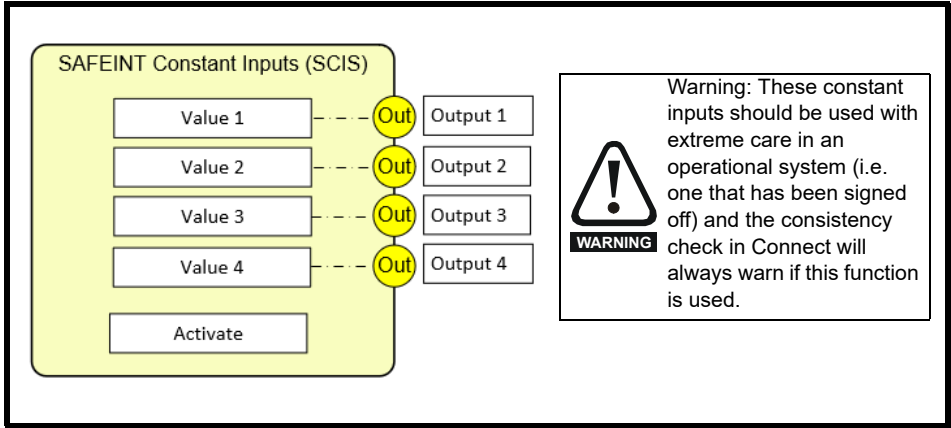

Name	Description
Value 1	Contains a 32 bit constant that is placed in Constant 1
Value 2	Contains a 32 bit constant that is placed in Constant 2
Value 3	Contains a 32 bit constant that is placed in Constant 3
Value 4	Contains a 32 bit constant that is placed in Constant 4
Output 1	See Above
Output 2	See Above
Output 3	See Above
Output 4	See Above
Activate	This parameter is used to activate the function. Connect will set this value to true when an MSF is selected. TRUE: function will be executed. FALSE: function is deactivated.

## 8.34 Non-Safe Boolean Input, BIS

Each instance provides access to 4 non-safe Boolean inputs that are routed through the setup menu (see section 9.5.3).

The state of each input value is updated at the start of every cycle before the motion safety functions are run. Unless the whole function instance is deactivated the output connectors for the instance are always updated even if the input is not used. It is not required that any of them should be connected.

These inputs must not be used to carry any safety signal, they are intended for edge triggered reset signals and other inputs with selectors that can accept a non-safe input.

**Figure 8-89 Diagrammatic representation of BIS**

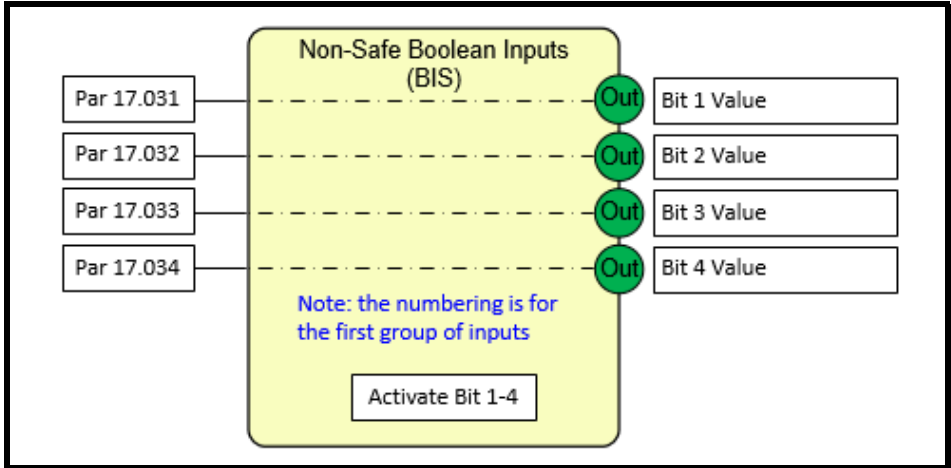

### Standards:

IEC 418: 1992

3. Definitions

4.1.12. Resetting the control device shall not by itself cause a restart command.

IEC 954-1: 1996

5.4 Manual reset.

ISO 12100-2: 2003

4.11.4: Restart following power failure/spontaneous restart.

IEC 60204-1, 1997

9.2.2. Stop Functions.

### Number of Instances: 4

Instance 1 - Bits 1-4

Instance 2 - Bits 5-8

Instance 3 - Bits 9-12

Instance 4 - Bits 13-16

Name	Description
Bit 1 Value	The state of the associated bit parameter in the setup menu For instance 1, Parameter 17.031 maps to Parameter 91.041 For instance 2, Parameter 17.035 maps to Parameter 91.141 For instance 3, Parameter 17.039 maps to Parameter 91.241 For instance 4, Parameter 17.043 maps to Parameter 91.341

Name	Description
Bit 2 Value	The state of the associated bit parameter in the setup menu For instance 1, Parameter 17.032 maps to Parameter 91.042 For instance 2, Parameter 17.036 maps to Parameter 91.142 For instance 3, Parameter 17.040 maps to Parameter 91.242 For instance 4, Parameter 17.044 maps to Parameter 91.342
Bit 3 Value	The state of the associated bit parameter in the setup menu For instance 1, Parameter 17.033 maps to Parameter 91.043 For instance 2, Parameter 17.037 maps to Parameter 91.143 For instance 3, Parameter 17.041 maps to Parameter 91.243 For instance 4, Parameter 17.045 maps to Parameter 91.343
Bit 4 Value	The state of the associated bit parameter in the setup menu For instance 1, Parameter 17.034 maps to Parameter 91.044 For instance 2, Parameter 17.038 maps to Parameter 91.144 For instance 3, Parameter 17.042 maps to Parameter 91.244 For instance 4, Parameter 17.046 maps to Parameter 91.344
Activate Bit 1-4	This parameter is used to activate the function. Connect will set this value to true when an MSF is selected. TRUE: function will be executed. FALSE: function is deactivated.

### 8.35 Non-Safe Boolean Output, BOS

Each instance provides access to 4 non-safe Boolean outputs that are routed through the setup menu (see section 9.5.3).

Unless the whole function instance is deactivated the corresponding parameters are always updated even if the input selector is disconnected. It is not required that any of the selectors should be connected.

These outputs must not be used to carry any safety signal, they are intended for monitoring purposes and for initiating actions that the safety module will monitor and react to, for instance the SS function has a non-safe output that on a request for safe state, can be used to request that the drive stops, the output is provided for machine control, and is not part of the safety monitoring function

**Figure 8-90 Diagrammatic representation of BOS**

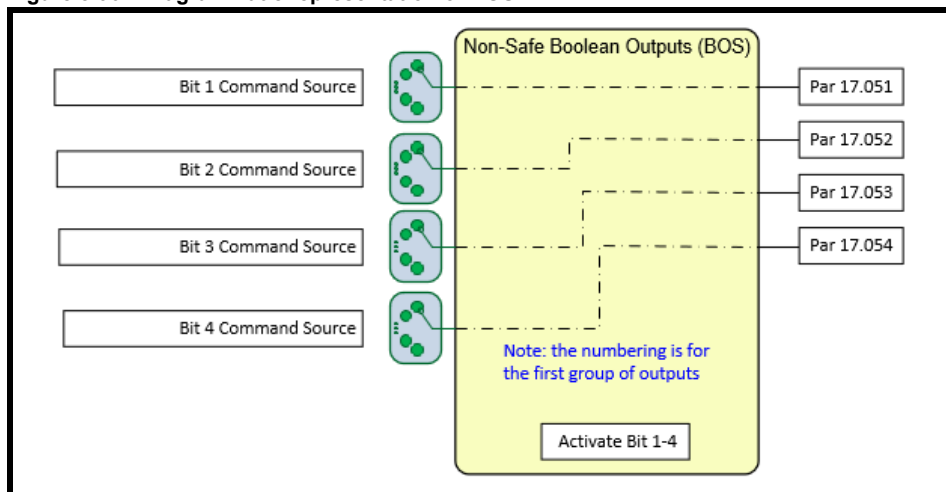

**Number of Instances: 4**

Instance 1 – Bits 1-4

Instance 2 – Bits 5-8

Instance 3 – Bits 9-12

Instance 4 – Bits 13-16

Name	Description
Bit 1 Command Source	The state of the associated bit parameter in the setup menu For instance 1, the value selected by parameter 031 goes to Parameters 17.051 For instance 2, the value selected by parameter 131 goes to Parameters 17.055 For instance 3, the value selected by parameter 231 goes to Parameters 17.059 For instance 4, the value selected by parameter 331 goes to Parameters 17.063
Bit 2 Command Source	The state of the associated bit parameter in the setup menu For instance 1, the value selected by parameter 032 goes to Parameter 17.052 For instance 2, the value selected by parameter 132 goes to Parameter 17.056 For instance 3, the value selected by parameter 232 goes to Parameter 17.060 For instance 4, the value selected by parameter 332 goes to Parameter 17.064
Bit 3 Command Source	The state of the associated bit parameter in the setup menu For instance 1, the value selected by parameter 033 goes to Parameter 17.053 For instance 2, the value selected by parameter 133 goes to Parameter 17.057 For instance 3, the value selected by parameter 233 goes to Parameter 17.061 For instance 4, the value selected by parameter 333 goes to Parameter 17.065
Bit 4 Command Source	The state of the associated bit parameter in the setup menu For instance 1, the value selected by parameter 034 goes to Parameter 17.054 For instance 2, the value selected by parameter 134 goes to Parameter 17.058 For instance 3, the value selected by parameter 234 goes to Parameter 17.062 For instance 4, the value selected by parameter 334 goes to Parameter 17.066
Activate	This parameter is used to activate the function. Connect will set this value to true when an MSF is selected. TRUE: function will be executed. FALSE: function is deactivated.

# 9 Diagnostics and Maintenance

## 9.1 Diagnostic code categories

The diagnostic codes provided by the MiS2x0 can be split into two categories. The first category is the diagnostic codes provided as a result of normal operation. The second category are those diagnostic codes that result from hardware or software execution faults. The categories are subdivided into types each resulting in a specific action taken by the MiS2x0. The action required to return the safety system to an operational state depends on the category and type of diagnostic code raised.

### 9.1.1 Operational diagnostics category

There are two types of operational Diagnostics, Alarms and Errors.

#### Alarms

**Cause:** - There are two types of alarm that can be raised by the MiS2x0 Safety Module, System Level and MSF Level. System Level Alarms are raised when errors in the supporting equipment such as Encoders or Networks are detected during operation. MSF alarms are raised when the system fails to operate within specified limits. Not all Motion Safety Functions cause alarms to be raised for example Safe Direction. More complex Motion Safety Functions such as Safely Limited Speed by default raise an alarm but can be set not to raise an alarm by the safety system designer.

**Reaction:** - An Alarm will cause the safe outputs (Hardware and Network) of the MiS2x0 to be set to a safe state. The MiS2x0 continues to run in a cyclic manner to service all requirements of the communication interfaces but ceases evaluation of the configured Motion Safety Functions. The Alarm will be recorded in the MiS2x0 EEPROM.

**Return to operation:** - When the cause of the Alarm has been cleared the MiS2x0 can continue to run. The mechanism to return to operation will depend on the source of the Alarm and the configuration of the item that caused the alarm. A System Alarm can be configured to clear on power up, clear on command from a safe input, or clear automatically when the fault has been cleared. Similarly, an MSF Alarm can be configured to clear using the system reset when the alarm condition is removed, or on command of a safe input. (See section 8.2)

#### Errors

**Cause:** - Errors are raised when a Motion Safety Function detects an incorrect input state which needs to be corrected before the Motion Safety Function can transition from its current state to the next operational state. For example, if a function requires a reset the Motion Safety Function will be expecting a rising edge. An error will be raised if the reset signal is set at a '1' hence a rising edge cannot occur until the reset switch sets the signal back to '0'. Other errors may require a reset to clear the error when the error condition has been removed

**Reaction:** - The Motion Safety function will wait in the error state until the error is cleared. An alarm will not be produced and hence will have no effect on the system.

**Return to operation:** - The Motion Safety Function raising the error will return to operation when the error is removed and if configured, when a reset is applied.

The table below provides a summary of Operational Alarms, and errors.

Information
Introduction
Technical Safety Features
Installation
Connect Configuration Tool Introduction
Start Up
Validation
Motion Safety Function Details
<b>Diagnostics and Maintenance</b>
Key Safety Data
Version Control (Amendments)

**Table 9-1 Operational diagnostics**

Type	Source	Impact on System	Reset
Alarm	System Alarm: - Operation of a peripheral or the Drive is performing outside normal parameters MSF Alarm: - The Motion Safety Function configuration has detected that the inputs are outside the user defined limits.	All outputs are switched off. The system continues running in a cyclic manner to service all requirements of the communication interfaces. The motion safety functions stop. operating until the reset is detected.	System alarm can be configured to i. Reset on power cycle, ii. require a rising edge on a safe input, iii. automatic reset when the fault is cleared An MSF Alarm can be configured to i. Reset by the system reset, ii. require a rising edge on a safe input.
Error (Refer to MSF Details, section 8)	An MSF has detected a condition that prevents normal operation, ranging from an envelope breach where an alarm is raised, to an input being in a state that need to change before the state machine can transition.	The error itself has no impact on the system unless it raises an alarm. Errors do affect the motion safety function they belong to.	Some automatically reset when the error clears, others may need a reset.

### 9.1.2 Fault diagnostics category

There are three types of Fault Diagnostic codes, Peripheral Faults, Configuration Faults, and Internal Faults. Peripheral Faults are associated with peripherals connected to the MiS2x0's encoder interfaces, network devices (via the Drive), host drive interface, and hardware outputs. Configuration Faults are to do with the configuration file downloaded and Internal Faults are those which are detected within the MiS2x0 Hardware or the operation of the MiS2x0 software. All faults will be written to the MiS2x0 internal EEPROM hence can be examined after a power cycle. In certain fault situations due to the potential severity of the fault detected it is possible it may not be stored. All faults result in an immediate halt of the processor.

#### Peripheral faults

**Cause:** - Peripheral Faults are those faults that can be associated with the connected peripherals. For example, when an encoder cable has become disconnected and communications with the encoder is lost.

**Reaction:** - On detection of a Peripheral Fault the MiS2x0 will cause the safe outputs of the MiS2x0 to be set to a safe state. The MiS2x0 will enter a failure state.

**Return to operation:** - The default for the MiS2x0 is to enter a failure state which will require maintenance intervention to return the MiS2x0 to the operational state using the Connect Configuration Tool. Alternatively, the system designer can select these faults to be cleared by performing a power cycle, and then acknowledging the fault from a safe input.

#### Configuration faults

**Cause:** - Configuration Faults are those faults that can be associated with the download and the content of the Configuration File created in Connect.

**Reaction:** - On detection of a Configuration Fault the MiS2x0 will cause the safe outputs of the MiS2x0 to be set to a safe state. The MiS2x0 will enter a failure state.

**Return to operation:** - The MiS2x0 will enter a failure state which will require maintenance intervention to return the MiS2x0 to the operational state using the Connect Configuration Tool.

## Internal faults

**Cause:** - Internal Faults are those associated with the MiS2x0 hardware or the operation of the software. Faults in the hardware around the MiS2x0 processor are detected by the continuous built in self test. The processor has embedded features that allow the detection of processor hardware faults, clocks, timers, memory and processor faults and software execution faults.

**Reaction:-** On detection of a fault the MiS2x0 will set the safe outputs to a safe state and will always attempt to record the fault in the EEPROM and put the module into the Failure State so as the fault is reported. However, it is possible if the fault is severe that the fault may not be stored or reported, BUT the outputs will always go safe. Should the MiS2x0 be operational and suddenly appear to stop with no error code this should be interpreted as an Internal fault.

**Return to Operation:** - The MiS2x0 should not be returned to operation if an internal fault has occurred. The MiS2x0 should be replaced, and the faulty unit returned to CT -technical support for fault diagnosis

The table below provides a summary of the fault diagnostics - Peripheral and Internal faults.

**Table 9-2 Fault Diagnostics**

Type	Source	Impact on System	Reset
Peripheral Faults	A fault is detected in a peripheral connected to the MiS2x0. Specific faults that relate to peripherals can be reset if the configuration is set for this.	All outputs are switched off. The failure is stored in the EEPROM and the user is notified via the drive keypad or Connect if it is connected.	Power Cycle and returns to Operating and waits for a Fault Acknowledge to be triggered if configuration is set for this otherwise enters Standby and need Connect to move to Operating.
Configuring Faults	An fault is detected in the operation of a test	All outputs are switched off. The failure is stored in the EEPROM and the user is notified via the drive keypad or Connect if it is connected.	Power Cycle and starts up in Standby, so Connect needed to move to Operating after corrected Configuration.
Internal Fault	Serious exception error caused by a function running in MiS2x0 SafetyModule or by a hardware failure	All outputs are switched off and failure stored in EEPROM if possible.	MiS2x0 should not be returned to operation

## 9.2 MiS2x0 alarm list

The System Alarm reported is built up of a number of separate alarm codes and so multiple alarms listed below can be reported at once. The following table is to aid with decoding this.

**Table 9-3 System alarm combination**

31	30	29	28	27	26	25	24	23	22	21	20	19	18	17	16	15	14	13	12	11	10	9	8	7	6	5	4	3	2	1	0
x	x	x	x	x	x	x	x	x	x	x	x	x	x	x	x	x	x	x	x	x	x	x	x	0	0	1	1	0	1	0	0
Encoder Alarms								Input Alarms				Internal Check			Config Changed			Network Alarms			0x3 System Alarm			0x4 ID							

So 0x1B200434 would mean the following alarms are present, Encoder 2 Decoded Word Incorrect, Input 2 Discrepancy Timeout and Network Not Available

**Table 9-4 System Alarm Codes**

Code	Message	Type
0x00000134	Shared Memory Alive Counter Timed Out	Network Alarm
0x00000234	Shared Memory Reports Drive Brown Out	Network Alarm
0x00000334	Communications Module Error, Check Black Channel Enabled	Network Alarm
0x00000434	Network Not Available see Setup Menu Parameter 028	Network Alarm
0x00000534	Shared Memory Reports Invalid Network Input Data	Network Alarm
0x01000034	Encoder 1 Het Block Error	Encoder Alarm
0x02000034	Encoder 1 Endat 2.2 CRC 1 Error	Encoder Alarm
0x03000034	Encoder 1 Safe Endat 2.2 CRC 2 Error	Encoder Alarm
0x04000034	Encoder 1 Endat 2.2 Error 1 Set	Encoder Alarm
0x05000034	Encoder 1 Endat 2.2 Error 2 Set	Encoder Alarm
0x06000034	Encoder 1 Timeout Transaction	Encoder Alarm
0x07000034	Encoder 1 AB or Sin/Cos Counter Error	Encoder Alarm
0x08000034	Encoder Position Mismatch	Encoder Alarm
0x09000034	Encoder Speed Mismatch	Encoder Alarm
0x0A000034	Heidenhain Test Failed	Encoder Alarm
0x0B000034	Encoder 1 Decoded Word Incorrect	Encoder Alarm
0x11000034	Encoder 2 Het Block Error	Encoder Alarm
0x12000034	Encoder 2 Endat 2.2 CRC 1 Error	Encoder Alarm
0x13000034	Encoder 2 Safe Endat 2.2 CRC 2 Error	Encoder Alarm
0x14000034	Encoder 2 Endat 2.2 Error 1 Set	Encoder Alarm
0x15000034	Encoder 2 Endat 2.2 Error 2 Set	Encoder Alarm
0x16000034	Encoder 2 Timeout Transaction	Encoder Alarm
0x17000034	Encoder 2 AB or Sin/Cos Counter Error	Encoder Alarm
0x1B000034	Encoder 2 Decoded Word Incorrect	Encoder Alarm
0x00100034	Input 1 Discrepancy Timeout	Input Alarm
0x00200034	Input 2 Discrepancy Timeout	Input Alarm
0x00300034	Input 3 Discrepancy Timeout	Input Alarm
0x00400034	Input 4 Discrepancy Timeout	Input Alarm
0x00001034	User Configuration Changed	Config Changed
0x00010034	MSF Alarm Check Toggle Error	Internal Check
0x00030034	Position Lost due to Wrap, Power Cycle and Re Datum	Internal Check
0x00040034	Mode State & Datum Sector is full, Please Power Cycle	Internal Check
0x00050034	Mode State & Datum Sector has 10% left, Please Power Cycle	Internal Check

The MSF Alarm is built up in the following way where "i" is the instance number of the MSF, so SLS instance 1 would be 160 and SLS instance 2 would be 161. For the specific alarms see the individual MSF sections within the manual.

**Table 9-5 MSF Alarm codes**

31	30	29	28	27	26	25	24	23	22	21	20	19	18	17	16	15	14	13	12	11	10	9	8	7	6	5	4	3	2	1	0
x	x	x	x	x	x	x	x	x	x	x	x	x	x	x	x	x	x	x	x	x	x	x	x	0	1	0	0	0	1	0	0
Function Instance Number 15i - Safe Stop 16i - Safely Limited Speed 30i - Safe Operating Stop 32i - Safely Limited Acceleration 36i - Safely Limited Position 39i - Safe Brake Control										Lowest 14 bits of Function Specific Code E.G.: 0xC005 = 00 0000 0000 0101b = 5										0x4 MSF Alarm				0x4 ID							

### 9.3 MiS2x0 fault list

The user can see the last fault code reported by the MiS2x0 Safety Module by viewing Menu 16/17 Parameter 014 (see section 9.5.3) or the current fault (if there is one) on the Connect dashboard.

PF - Peripheral Faults that can be cleared after a power cycle and a fault acknowledge (See section 8.2)

CF - Configuring Faults, the fault is stored in internal memory before entering the failure state.

IF - Internal Faults, enters the failure state and stores fault if possible.

**Table 9-6 MiS2x0 fault codes**

Code	Message	Type		
0x00000010	Internal Module Failure. Contact the supplier of the Drive	IF		
0x00000020				
0x00000030				
0x00000011				
0x00000021				
0x00000031				
0x00000003				
0x00000023				
0x00000033				
0x00000043				
0x00000053				
0x00000063				
0x00000073				
0x00000083				
0x00000093				
0x000000A3				
0x000000B3				
0x000000C3			Failed to configure Drive to snoop Encoders. Check Drive firmware version	PF
0x000000D3			Selected Encoders are not a valid combination	CF
0x000000E3	Internal Module Failure. Contact the supplier of the Drive	IF		
0x000000E3				
0x00000014				
0x00000114				
0x00000214				
0x00000314				
0x00000024	Scheduler overrun. Configuration is too big to be ran in the 1 ms cycle time	CF		

Code	Message	Type
0x00000224	Internal Module Failure. Contact the supplier of the Drive	IF
0x00000005	Configuration download failed. Possible loss of power during download, use Connect to download again	CF
0x00000015	Internal Module Failure. Contact the supplier of the Drive	IF
0x00000025	Can't communicate with drive, Power Cycle Drive	PF
0x00000125	Internal Module Failure. Contact the supplier of the Drive	IF
0x00000135		
0x00000235	Can't communicate with Drive at initialisation. Power Cycle Drive	PF
0x00000335	Drive firmware version incorrect	PF
0x00000435	Drive mode change event when system not in STANDBY state	PF
0x00000535	Drive restart event when system not in STANDBY state	PF
0x00000045	Safety Network Error. Check the communications module is configured for Black Channel	PF
0x00000145	Safety Network Error, too many messages received. Check message rate	PF
0x00000245	Safety Network Error, received, message too big. Check Configuration in	PF
0x00000345	CIPSafety Network Error, transmit queue full. Check Master is Receiving	PF
0x00000055	Internal Module Failure. Contact the supplier of the Drive	IF
0x00000155		
0x00000255	Safety Stack Generated Fail-Safe error during initialization. Power Cycle Drive	PF
0x00000355	Safety Network Error, communication between Modules not initialised. Check configuration	PF
0x00000455	Safety Module is fitted to a Drive that is not supported or communication module in incorrect slot	PF
0x00000555	Internal Module Failure. Contact the supplier of the Drive	IF
0x00000065	Communications to Drive have Failed. Power Cycle Drive	PF
0x00xxxx65	Fail Safe Error generated by CIPSafety (xxxx = CIPSafety Stack Code). Power Cycle	PF
0xxxxxxx75	Fail Safe Error generated by FSoE (xxxxxx = FSoE Stack Code). Power Cycle	PF
0x00000185	Failed to initialize EtherCAT communications module. Check communication module configuration and state	PF
0x00000285	Failed to reset the FSoE connection. Check communication module configuration and state	PF
0x00000385	EtherCAT command received in wrong state or is unknown. Check communication module configuration and state	PF
0x00000485	FSoE configuration too large. Check settings in Master match Safety Module	PF
0x00000016	Internal Module Failure. Contact the supplier of the Drive	IF
0x00000026		
0x00000036	Login Block is full. Perform a Factory reset	CF
0x00000046	Read returns that a sector is empty. Normal behaviour with a New Module or a Factory Reset Module	PF
0x00000066	Mode State & Datum sector full. Power Cycle Drive	CF

Code	Message	Type
0x00000017	Internal Module Failure. Contact the supplier of the Drive	IF
0x00000117		
0x00000317		
0x00000417		
0x00000517		
0x00000617		
0x00000717		
0x00000817		
0x00000917	Encoder Diagnostic: Encoder Failure, no valid data. Check the Encoder cables	PF
0x00000027		
0x00000127	Internal Module Failure. Contact the supplier of the Drive	IF
0x00000227		
0x00000097		
0x00000197		
0x000000A7		
0x000000B7	Configuration not ready, download in progress	CF
0x000001B7	Consistency check failed. Configuration is not valid	CF
0x000002B7	Stored configuration not valid. Configuration needs to be downloaded	CF
0x000003B7	Hardware compatibility test failed. Configuration not compatible with the hardware detected	PF
0x000004B7	Configuration file database version does not match firmware	CF
0x000007B7	Encoder power supply configuration error or invalid encoder combination. Seen when Endata2.1 used in place of Endat 2.2	CF
0x000000C7	Internal Module Failure. Contact the supplier of the Drive	IF
0x000001C7	Internal Module Failure. Contact the supplier of the Drive	IF
0x000002C7	System signature check failed (downloaded configuration CRC check failed)	CF
0x000004C7	Internal Module Failure. Contact the supplier of the Drive	IF
0x000000D7		
0x000001D7		
0x000000E7		
0x000001E7		
0x000002E7		
0x000003E7		
0x000004E7		
0x000005E7	Encoder 5 V Self-Test Range Error	PF
0x000006E7	Encoder 8 V Self-Test Range Error	PF
0x000007E7	Encoder 15 V Self-Test Range Error	PF
0x000008E7	PSU 24 V Self-Test Range Error	PF
0x000009E7	Internal Module Failure. Contact the supplier of the Drive	IF
0x00000AE7		
0x00000BE7	Encoder 5 V Range Error	PF
0x00000CE7		
0x00000DE7		
0x00000EE7		
0x00000FE7		
0x00000FE7	Encoder 8 V Range Error	PF
0x00000EE7	Encoder 15 V Range Error	PF
0x00000FE7	PSU 24 V Range Error	PF

Information
Introduction
Technical Safety Features
Installation
Connect Configuration Tool Introduction
Start Up
Validation
Motion Safety Function Details
<b>Diagnoses and Maintenance</b>
Key Safety Data
Version Control (Amendments)

Code	Message	Type
0x000010E7	Internal Module Failure. Contact the supplier of the Drive	IF
0x000011E7		
0x000012E7		
0x000013E7		
0x000014E7	PSU 24 V Brownout detected resulting in a restart	PF
0x000000F7	Invalid Drive and MiS2x0 board combination	PF
0x000001F7	Internal Module Failure. Contact the supplier of the Drive	IF
0x000010F7		
0x000020F7	Temperature Max Value Error, The Module is overheating	PF
0x000021F7	Internal Module Failure. Contact the supplier of the Drive	IF
0x000022F7		
0x000023F7		
0x000030F7	Safe Output Self Test Error in Standby Mode, Check Output Wiring Can occur on Power down of a Digitax and can be ignored under these conditions	PF
0x000031F7	Safe Output Self Test Error in Operating Mode, Check Output Wiring Can occur on Power down of a Digitax and can be ignored under these conditions	PF
0x000032F7	Internal Module Failure. Contact the supplier of the Drive	IF
0x000033F7		
0x000034F7		
0x000035F7		
0x000036F7		
0x000040F7		
0x000041F7		
0x000042F7		
0x000043F7		
0x000044F7		
0x000045F7		
0x000046F7		
0x000047F7		
0x000048F7		
0x000049F7		
0x00004AF7		
0x00004BF7		
0x00004CF7		
0x00004DF7		
0x00004EF7		
0x00004FF7		
0x000050F7	Can occur if Safe Outputs are Short Circuited Internal Module Failure. Contact the supplier of the Drive if persists	IF
0x000051F7	Can occur if Safe Outputs are Short Circuited Internal Module Failure. Contact the supplier of the Drive if persists	IF
0x000052F7	Internal Module Failure. Contact the supplier of the Drive	IF
0x00000x19		

## 9.4 Safety DLL fault list

**Table 9-7 Safety DLL fault codes**

Code	Message
<b>FUNCTIONS</b>	
0x0FFFFFFE	Access Control – NULL was sent as Username (Not an Error)
0x0FFFFFFF	Session cleared successful (Not an Error)
0xFFFFFFFF	Unknown Error
0x80000002	BC Create does not support message type passed
0x80000004	CRC Check Failed. Data block corrupted
0x80000008	Log in information (LID) does not match. Possible unauthorized user
0x80000010	Difference between timestamps too big - Timeout
0x80000018	Log in information (LID) does not match. Possible unauthorized user Difference between timestamps too big - Timeout
0x8000001C	CRC Check Failed. Data block corrupted Log in information (LID) does not match. Possible unauthorized user Difference between timestamps too big - Timeout
0x80000014	CRC Check Failed. Data block corrupted Difference between timestamps too big - Timeout
0x8000000C	CRC Check Failed. Data block corrupted Log in information (LID) does not match. Possible unauthorized user
0x80000020	Get System Time returned time smaller or equal to 0.
0x80000040	Encrypt or Decrypt received an unsupported data block (Incorrect Byte Count)
0x80000080	Decrypt received unencrypted data block (Block ID = 0)
0x80010000	CDB block is incorrect. 8001nn00 bits 16-23 (nn) are reserved for number of faults in the difference list.
0x80040000	Invalid login or password
0x80100000	Data block is too big to calculate its SHA1
0x80200000	Command code does not exist on ECMP or parameter list
0x80400000	Full or corrupted RPF file
0x80800000	RPF file generated for a different database or corrupt database
0x81000000	Error in comparison process of CDB block(S). 81nnnn00 bits 8-23 hold FAULT code from fault table
0xC0000000	One or more of input pointers are NULL
<b>DATABASE</b>	
0x80010000	Serious Database Fault
0x80020000	Non-User Save Parameter In RPF
0x80040000	Non-Existing Menu
0x80080000	Non-Existing Parameter
0x80100000	Invalid Parameter Format
0x80200000	Invalid Parameter Value (Too High)
0x80400000	Invalid Parameter Value (Too Low)
0x80800000	Duplicated Parameter In RPF
0x81000000	Fatal Error RPF Cannot Be Read
0x82000000	Unsupported Size
0x84000000	Location Out of Scope Of Database Or RPF
0x88000000	Empty Parameter Attribute
0x90000000	Unsupported Size of Parameter Value

Information
Introduction
Technical Safety Features
Installation
Connect/Configuration Tool Introduction
Start Up
Validation
Motion Safety Function Details
<b>Diagnoses and Maintenance</b>
Key Safety Data
Version Control (Amendments)

Code	Message
<b>FUNCTIONS</b>	
0xA0000000	Incomplete RPF Configuration
0xC0000000	Incorrect RAM Location
<b>VALIDATION RULES</b>	
0x00007530	Problem Outside of The Rules (Possibly with The Core DB)
0x00007918	Broken, unreadable RPF File
0x00004268	Incorrectly defined Range
0x00003E80	Input selector connected to invalid parameter (parameter does not exist, is not a valid source or belongs to a function that is not in use)
0x00003A98	Safe Input selector connected to unsafe source
0x000036B0	Active SAFEBOOL output is not selected by any SAFEBOOL input selector
0x000032C8	Active SAFEBOOL input selector is not connected to any SAFEBOOL output
0x00002EE0	Speed or Acceleration needed by MSF, compatible encoder type is not selected or configured
0x00002AF8	Position needed by MSF, compatible encoder type is not selected or configured
0x00002710	Faulty RPF, parameter in deactivated function is not set to default value
0x00002328	Number of activated MSF instances exceeds maximum (100)
0x00001F40	Activated MSF instance is not on execution order list
0x00001F41	The same activated MSF instance is present on execution order list more than once
0x00001B58	Incorrect execution order list, configuration can not be completed in one cycle
0x00001770	Loop in Configuration
0x00001388	Secondary encoder channel is incorrectly configured in presence of dual channel safety encoder on primary channel
0x00000FA0	Primary encoder not in use or using same source as secondary encoder
0x00000BB8	Incorrect filter time for pulsed inputs
0x000007D0	Invalid parameter value or format
0x000007D1	Invalid parameter format
0x000007D2	Parameter value is too low
0x000007D3	Parameter value is too high
0x000003E8	Invalid RPF file
0x000003E9	Invalid RPF file - duplicated parameter
0x000003EA	Incomplete RPF file – missing parameter

## 9.5 Maintenance



- This device can only be repaired by Nidec Control Techniques Ltd.
- The warranty is void if the MiS2x0 Safety Module is opened or modified in any way.
- Under no circumstances should the Local Connectors on the MiS2x0 Safety Module be disconnected or reconnected while power is applied to the device, as there is a risk of failure or permanent damage to the connected encoders.
- Internal Faults must not be ignored
- The MiS2x0 must be replaced if an internal fault occurs.
- Faults must not be ignored using the Peripheral Fault Reset feature
- Fault Clearance action must support the peripheral fault code detected
- Any replacement parts e.g. Encoders, must be like for like
- Maintenance must be performed by suitably qualified experienced personnel

### 9.5.1 Module replacement

In order to replace a MiS2x0 Safety Module the installation description in Section 5 should be followed and then the module should be configured using Connect.

### 9.5.2 Maintenance intervals

The MiS2x0 Safety Module has a life of 20 years and runs a built-in test which provides a high degree of diagnostic coverage. The testing of key built in test features is performed at power on and MUST be repeated by power cycling the MiS2x0 at least once a year.

### 9.5.3 Diagnostic parameters (Module menu)

The parameters that are updated by MiS2x0 Safety Module are all within Menu 17 on M6xx-M7xx, the module menu (also known as Setup Menu) it is always visible using a keypad or communications. On Digitax drives this is Menu 16.

The Keypad Language File should be "Language Files\_V3\_Keypad Language V3-English (4.4.5.99).keypadLang"

If the Module displays Safety Failure in Parameter 004, this could be due to several things such as the configuration does not match the actual peripherals connected. Also look at Parameters 013 (Last Alarm) and 014 (Last Fault) for further details.

**Table 9-8 Module Menu Parameters**

Parameter	Name	Description
001	Module ID	502 for MiS210 and 503 for MiS250
002	Software Version	
003	Hardware Version	0 for both MiS210 and MiS250
004	Module Alarm Code	Contain strings that can be displayed on the drive display in the event of certain module conditions 0 - "Safety Failure" 1 - "Drive Firmware" 2 - "Safety Alarm" 3 - "Configuration" (Configuration not valid) 4 - "Module Healthy" 5 - "Read Par 15.012" 6 - "Read Par 17.012" 7 - "Read Par 24.012"
005	Module Trip Code	Contain strings that can be displayed when the module initiates a drive trip 0 - "Healthy" 1 - "Module reset"

Parameter	Name	Description
006	System Signature Word 3	Bits 48 – 63 of signature displayed in HEX
007	System Signature Word 2	Bits 32 – 47 of signature displayed in HEX
008	System Signature Word 1	Bits 16 – 31 of signature displayed in HEX
009	System Signature Word 0	Bits 0 – 15 of signature displayed in HEX
010	Safety Mode	0 – "Idle": In a safe state and waiting for commands 1 – "Operating": monitoring the machine state 2 – "Configuring": can be configured and tested
011	Safety State	0 - "Failure": unrecoverable fault must be power cycled. 1 - "Standby": starting up or waiting for user instructions. 2 - "Executing": monitoring the machine. 3 - "Download": waiting for or receiving a configuration. 4 - "Test-Comm-On": config mode communications on.
012	Round Trip Code	Generated by MiS210 during identification, stopping execution, and setting factory defaults. It must be read by the user and entered into Connect when it asks for a verification code to be entered
013	Last Alarm Code	Contains the last alarm code generated by the MiS210. Alarms cause the MiS210 outputs to go to safe state but they can be reset
014	Last Fault Code	Contains the last fault code generated by the MiS210. Faults cause the MiS210 outputs to go to safe state and cannot be reset, a power cycle is required.
015	Log In Status	0 – "Logged Out" 1 – "Logged In"
016	Time Stamp Coarse	Time stamp parameter hrs:min:sec To be copied into PLC as the part of the Configuration signature.
017	Time Stamp Fine	Time stamp parameter (ms) To be copied into the PLC as part of the Configuration signature.
018	Date Stamp Day/Month	Date stamp Parameter dd.mm To be copied into the PLC as part of the Configuration signature.
019	Date Stamp Year	Date stamp Parameter YYYY To be copied into the PLC as part of the Configuration signature.
020	Safety Network Indication 1	State values of the Safety Supervisor object in CIP Safety: 0 - "NULL" - Never seen if network enabled. 1 - "SELF TEST" - Module self-test. 2 - "IDLE" - Device self-test passed and configured, but no valid data transfer from MiS210 to PLC. 3 - "SELF TEST FAULT" - Self test at power up failed. 4 - "EXECUTE" Data being transferred from device to PLC. 5 - "ABORT" The device has entered a recoverable fault state. 6 - "CRITICAL FAULT" The device has entered a non-recoverable fault state and must be power cycled.
021	Safety Network Indication 2	Network Status in CIP Safety 0 - "OFF LINE" - No Network communications 1 - "LINK OK" - Device online and connections validated 2 - "ON LINE NO LINK" - Online but no connection yet validated 3 - "Timeout" - One or more connection Timed out 4 - "LINK FAULT" - Connection to Network not possible 5 - "CFRICFR" - Critical Fault and received an Identify Comm Fault Request. Normally used to set a TUNID in a safety device and so should not be seen on the device as the TUNID is set in the configuration.

Parameter	Name	Description	
022	Safety Network Indication 3	Network Status in FSoE 0 - "Not used" - FSoE Not Configured 1 - "Reset" - Connection not initialised or faulted 2 - "Session" - Interchanging of Session ID 4 - "Connection" - Connection ID and Slave Address Transfer 8 - "Parameter" - Transfer of Watchdog Time and Application Parameters 16 - "Data" - Data transfer between Master and Slave	Information
023	Safety Network Indication 4	0 – "Not used"	Introduction
024	Safety Network Indication 5	0 – "Not used"	Technical Safety Features
025	EMPTY		
026	Safety Network	The number of received data messages per second from the PLC.	
027	Safety Network Expectation Margin	The margin between the latest message received and the set timeout in ms.	Installation
028	Safety Network Status Flags	Device internal flags indicating network status: Bit 0 - Comms module safety buffer not yet set up. Bit 1 - A Fail-Safe error has been generated by the Safety Stack. Bit 2 - Connection for receiving data is not yet valid. Bit 3 - Connection for sending data is not yet valid. Bit 4 - Toggled every time a valid Input message is received. Bit 5 - A Reset has been received from the network to reset an Alarm condition. Bit 6 - A Remote Error generated by the master	Connect Configuration Tool Introduction
029 - 030	EMPTY		Start Up
031 - 046	None Safe Inputs 1 – 16	Bit Parameters that can be used as non-safe inputs to the motion safety functions. Users must route the required values to these parameters.	Validation
047 - 050	EMPTY		
051 - 066	Non-Safe Outputs 1 - 16	Bit parameters that are written to by the motion safety functions as Non-Safe outputs. Users must route these outputs to the required function.	Motion Safety Function Details
067	EMPTY		
068	Percentage Cycle Time Used	Percentage used while running of the available 1ms cycle time	
069	EMPTY		
070	Command Semaphore	These locations are used to transfer data between Connect and the device when in the executing state.	Diagnostics and Maintenance
071	Message Bytes 0-3		
072	Message Bytes 4-7		
073	Message Bytes 8-11		
074	Message Bytes 12-15		
075	Message Bytes 16-19		
076	Message Bytes 20-23		
077	Message Bytes 24-27		
078	Message Bytes 28-31		
079	Encoder 1 Sign Bit		
080	Encoder 1 Position 1	Encoder 1 Bits 63-48 (MS 16 bits of 64-bit word)	Version Control (Amendments)
081	Encoder 1 Position 2	Encoder 1 Bits 47-32	
082	Encoder 1 Position 3	Encoder 1 Bits 31-16	

Parameter	Name	Description
083	Encoder 1 Position 4	Encoder 1 Bits 15-0 (LS 16 bits of 64-bit word)
084	Encoder 2 Sign Bit	Encoder 2 Direction Sign
085	Encoder 2 Position 1	Encoder 2 Bits 63-48 (MS 16bits of 64-bit word)
086	Encoder 2 Position 2	Encoder 2 Bits 47-32
087	Encoder 2 Position 3	Encoder 2 Bits 31-16
088	Encoder 2 Position 4	Encoder 2 Bits 15-0 (LS 16bits of 64-bit word)
089	Invalidate Datum	If value is 1 (ON) a Request is made for the Safe Datum (SDM) to be executed to obtain a new position datum. See section 8.14 where use of this parameter is explained.
090 - 093	Scope Parameters	4, 32-bit parameters that can be configured to follow any of the safety module's protected parameters
094 - 096	EMPTY	
097	System State	16-bit parameter indicating the system state and if a reset is required. 0x0000 - System Initialize 0x8000 - MSFs Running Normally 0x8001 - System Ready 0x8002 - System Wait for Reset 0x8003 - System Reset Error 0x8004 - System Wait for Reset (Peripheral Error) 0xC001 - System Alarm, Check Last Alarm Code 0xC002 - Peripheral Reset Error 0xD000 - MSF Alarm, Check Last Alarm Code  Reset errors 0x8003 and 0xC002, will be shown until their associated Reset signal be logic FALSE, allowing a rising edge to be detected as a request to reset.



- The Diagnostic parameters are NOT reliable indicators and cannot be guaranteed to provide accurate information. They should ONLY be used for general diagnostics during commissioning or troubleshooting. Do not attempt to use parameters as operational indicators.

#### 9.5.4 Factory Reset

The MiS2x0 provides a facility to reset the MiS2x0 Safety Module to the out of box settings. This can be used to remove the Configuration and identification detail as well as erasing all alarm history.

Connect provides a button to perform a Factory Reset, once pressed the MiS2x0 Safety Module will display a code on the drive keypad (012 in the table above). This code must be entered into Connect and is sent back to the MiS2x0 Safety Module to confirm the reset is required.

Once a Factory Reset has occurred the MiS2x0 Safety Module enters a Failure state and must be power cycled before use.

# 10 Key Safety Data

**Table 10-1 Key Technical Indicators**

<b>KEY TECHNICAL SAFETY INDICATORS</b>	
PL in accordance with ISO 13849:2006	PL e
PFH (High Demand)	$9.32 \times 10^{-9} \text{ h}^{-1}$
SIL in accordance with IEC 61508	SIL 3
Partial Proof Test Interval	1 year
Product Life	20 years
Mean Time Between Failures	212983 hours at 50 °C
<b>GENERAL DATA</b>	
Input Connection Type	Green 14 pin socket
Encoder Connection Type	Black 14 pin socket
Wiring for Both Connections	Conductor cross section solid wire: 0.2 mm <sup>2</sup> - 1 mm <sup>2</sup> Conductor cross section stranded wire: 0.2 mm <sup>2</sup> - 1.5 mm <sup>2</sup> Conductor cross section flexible, with min ferrule without plastic sleeve: 0.25 mm <sup>2</sup> - 0.75 mm <sup>2</sup> Conductor cross section flexible, with min ferrule with plastic sleeve: 0.25 mm <sup>2</sup> - 0.5 mm <sup>2</sup> Ferrules are recommended and need to be at least 8 mm in length Metric Sizes for Ferrules with plastic sleeves: 0.25 mm <sup>2</sup> - 0.5 mm <sup>2</sup>
<b>ENVIRONMENTAL DATA</b>	
Operating Temperature	-20 °C to 40 °C (+55 °C with drive de-rating)
Storage Temperature	-40 °C to 70 °C
Protection Class (IP Rating)	IP 20
Pollution Degree	2
EMC	In accordance with IEC 61326-3-1:2017, IEC 61800-5-2:2017 and IEC 61800-3:2018
<b>ENCODER DATA</b>	
Maximum Frequency of Incremental Encoders	350 kHz
Maximum Data Clock Frequency for Digital Encoders	Master Mode 500 kHz
Maximum Data Clock Frequency for EnDat 2.2 Drive Snooping	4 MBaud
Encoder Signals	Digital Signals, TTL compatible, EIA-485 transceivers. Analogue signals for Sin/Cos type 1Vp-p. Max Frequency: 500 kHz (180 kHz for Sin/Cos). Line termination resistance of 120 Ω.
Encoder Power Supply Output	5 V and 8 V at 250 mA max. 15 V at 200 mA max.
Encoder Power Supply Monitoring	5 V, 8 V and 15 V
<b>IO DATA</b>	
Digital Inputs	0-24 V DC inputs as specified in IEC 61131-2 for Type 1 and 3 inputs. Maximum current for a 24 V input is 3 mA.
Digital Outputs	0-24 V DC 100 mA output as specified in IEC 61131-2. Maximum capacitance connected to the output = 10 nF <sup>2</sup>
Pulse Outputs	0-24 V pulses at 500 Hz, 50 % duty cycle.

<sup>1</sup>Encoders with outputs exceeding ±5.5 V relative to 0V are not compatible.

<sup>2</sup>If more capacitance is connected to the output an external pull-down resistor should be added (8.2 kΩ per 10 nF) between the output and the 0 V of the module.

Information
Introduction
Technical Safety Features
Installation
Connect/Configuration Tool Introduction
Start Up
Validation
Motion Safety Function Details
Diagnosics and Maintenance
Key Safety Data
Version Control (Amendments)

---

## 11 Version Control (Amendments)

---

The English version of this Installation and Operating Manual, part number 0478-0665-01, is the original and master version.

Index	Page	Date	Author	Modification
Draft	All	08/02/18	Kate McDougall	First Issue for Safety Team Review
Internal	All	22/02/18	Kate McDougall	For Review by Other Teams Not to go outside of CT
V1.0	All	19/10/18	Kate McDougall	Draft Version
V2.0	All	10/04/19	Kate McDougall	Customer Release - CIPSafety Comms
V2.1	All	09/03/21	Kate McDougall	Internal Phase 2 Release – CIPSafety & FSoE
V2.1	All	14/03/21	Kate McDougall	Phase 2 Customer Release – CIPSafety & FSoE
V2.1	All	28/05/21	Luke Orehawa	Phase 2 Customer Release
V2.1	All	17/09/21	Luke Orehawa	Phase 2 Customer Release
V3.0	All	23/09/21	Luke Orehawa	SLS diagrams, System fault table
V3.1	5.1.3, 8.2	13/10/21	Luke Orehawa	Important note regarding System Start and Auto Reset added
V3.2	10	24/11/21	Luke Orehawa	Added details to encoder digital signal voltage specification.





**0478-0665-01**